

AM263x Sitara™ 微控制器

1 特性

处理器内核：

- 单核、双核和四核 Arm® Cortex®-R5F MCU，每个内核运行频率高达 400 MHz
 - 16KB 指令缓存，每个 CPU 内核具有 64 位 ECC
 - 16KB 数据缓存，每个 CPU 内核具有 32 位 ECC
 - 64KB 紧耦合存储器 (TCM)，每个 R5F 内核具有 32 位 ECC
 - 锁步功能

存储器子系统：

- 2MB 片上 RAM (OCSRAM)
 - 4 组 x 512KB
 - ECC 错误保护
 - 支持内部 DMA 引擎

工业连接：

- 支持工业通信协议或电机控制接口的双核可编程实时单元和工业通信子系统 (PRU_ICSSM)：
 - EtherCAT®
 - PROFINET®
 - 以太网/IP™
 - IO-Link®
 - 编码器反馈
 - 通用输入/输出 (GPIO)

传感和驱动：

- 实时控制子系统 (CONTROLSS)
- 带可编程 DAC 基准的 20 个模拟比较器 (CMPSS)
- 5 个 12 位逐次逼近寄存器 (SAR) 模数转换器 (ADC)
 - 每个 ADC 高达 4 MSPS
 - 每个 ADC 6 个可选输入
 - 可配置为单端或差分输入
- 带缓冲输出的 1 个 12 位 DAC
- 32 个增强型高分辨率 PWM 模块 (EHRPWM)
 - 与 EPWM 相比，延长 PWM 的时间分辨率
 - 支持单端或差分输出
- 10 个增强型捕获模块 (ECAP)
- 3 个增强型正交编码器脉冲模块 (EQEP)

- 2 个 Δ - Σ 滤波器模块 (SDFM)，每个模块支持多达 4 个通道
- 灵活的信号复用交叉开关 (XBAR)

片上系统 (SoC) 服务和架构：

- 1 个 EDMA，支持数据移动功能
- 处理器间通信模块
 - 用于同步多核上运行的进程的自旋锁模块
 - 通过 CTRLMMR 寄存器实现的 MAILBOX 功能
- 支持从以下接口进行主引导：
 - UART
 - QSPI NOR 闪存
- 时间同步支持与时间同步和比较事件中断路由器

功能安全：

- 支持设计具有功能安全要求的系统
 - 计算临界存储器具有 ECC 或奇偶校验
 - CPU 和片上 RAM 的内置自检 (BIST) 和故障注入
 - 带有错误引脚的错误信号模块 (ESM)
 - 运行时安全诊断，电压、温度和时钟监控，窗口式看门狗计时器，用于存储器完整性检查的 CRC 引擎
- 以符合功能安全标准为目标 [工业]
 - 专为功能安全应用开发
 - 将提供相关文档来协助进行符合 IEC 61508 标准的功能安全系统设计
 - 以系统能力达到 SIL-3 级为目标
 - 以硬件完整性达到 SIL-3 级为目标
 - 安全相关认证
 - 计划通过 IEC 61508 认证
- 以符合功能安全标准为目标 [汽车]
 - 专为功能安全应用开发
 - 将提供相关文档来协助进行符合 ISO 26262 标准的功能安全系统设计
 - 以系统功能达到 ASIL-D 级为目标
 - 以硬件完整性达到 ASIL-D 级为目标
 - 安全相关认证
 - 计划通过的 ISO 26262 认证
- 符合面向汽车应用的 AEC-Q100 标准



安全性：

- 支持 Auto SHE 1.1/EVITA 的硬件安全模块 (HSM)
- 安全启动支持
 - 器件接管保护
 - 硬件强制可信根
 - 经认证的引导
 - 软件防回滚保护
- 调试安全
 - 只有通过正确的身份验证，才能调试 HS 器件
 - 配置为禁用调试
- 器件 ID 和密钥管理
 - 支持 OTP 存储器 (FUSEROM)，以存储根密钥和其他安全启用字段
 - 独立的 EFUSE 控制器和 FUSE ROM
 - 唯一器件公共 ID
- 存储器保护单元 (MPU)
 - Arm® MPU 存在于每个 Cortex®-R5F 内核中
 - 系统 MPU - 出现在 SoC 中的各种接口上 (可以是防火墙或 MPU)
 - 8-16 个区域
 - 可编程 (特权 ID、读取/写入/可缓存、开始/结束地址、启用、安全/非安全)
- 加密加速
 - 支持加密内核
 - AES - 128/192/256 位密钥大小
 - SHA2 - 256/384/512 位支持
 - 带有仿真随机数生成器的 DRBG
 - 可在 RSA/ECC 处理中提供帮助的 PKA (公钥加速器)
 - DMA 支持

高速接口：

- 支持两个外部端口的集成以太网交换机
 - RMI (10/100) 或 RGMII (10/100/1000)
 - IEEE1588 (2008 附件 D、E 和 F) 及 802.1AS PTP
 - 第 45 条 MDIO PHY 管理规范
 - 基于 ALE 引擎的数据包分类器，具有 512 个分类器
 - 基于优先级的流量控制
 - 数据包大小高达 2KB
 - 四个 CPU 硬件中断节奏
 - 硬件中的 IP/UDP/TCP 校验和卸载

连接：

- 6 个通用异步收发器 (UART)
- 5 个串行外设接口 (SPI) 控制器
- 5 个本地互连网络 (LIN) 端口
- 4 个内部集成电路 (I2C) 端口
- 4 个支持 CAN-FD 的模块化控制器局域网 (MCAN) 模块
- 1 个四线串行外设接口 (QSPI)
- 具有 4 个接收器内核和 4 个发送器内核的快速串行接口 (FSI)
- 多达 140 个通用 I/O (GPIO) 引脚

媒体和数据存储：

- 1 个多媒体卡/安全数字 (MMC/SD) 4 位接口
- 通用存储器控制器 (GPMC)
 - 16 位并行数据总线
 - 22 位地址总线
 - 高达 4MB 可寻址存储器空间
 - 支持错误检查的集成错误定位模块 (ELM)

技术/封装：

- 45nm 技术
- 15mm x 15mm、0.8mm 间距、324 引脚 NFBGA

2 应用

- [单轴及多轴伺服驱动器](#)
- [交流逆变器和变频驱动器](#)
- [太阳能](#)
- [电动汽车充电](#)
- [可再生能源存储](#)
- [牵引逆变器](#)
- [车载充电器](#)
- [直流/直流转换器](#)
- [电池管理系统](#)
- [整体式架构](#)
- [IO 聚合器](#)
- [域控制器](#)

3 说明

AM263x Sitara™ Arm® 微控制器旨在满足下一代工业和汽车嵌入式产品复杂的实时处理需求。AM263x MCU 系列由多个引脚对引脚兼容器件组成，具有多达四个 400-MHz Arm® Cortex®-R5F 内核。对于不同的功能安全配置，可以选择将多个 Arm® 内核编程为在锁步选项中运行。工业通信子系统 (ICSS) 支持集成工业以太网通信，例如 PROFINET IRT、TSN 或 EtherCAT® (以及许多其他工业以太网)，或用于标准以太网连接或自定义 I/O 接口。该系列设计用于先进的电机控制和带有先进模拟模块的数字电源控制应用。

多个 R5F 内核以 256KB 共享紧耦合存储器 (TCM) 和 2MB 共享 SRAM 的集群形式排列，无需外部存储器。片上存储器、外设和互联中包含广泛的 ECC，增强了可靠性。除了由 HSM 管理的细粒度防火墙之外，AM263x 器件上还提供加密加速和安全启动功能，供开发人员设计最为安全的系统。

TI 为 AM263x 系列微控制器提供了一整套微控制器软件和开发工具。

器件信息		
器件型号 ^{(1) (2)}	封装	封装尺寸
AM2634...ZCZ	NFBGA (324)	15mm × 15mm
AM2632...ZCZ	NFBGA (324)	15mm × 15mm
AM2631...ZCZ	NFBGA (324)	15mm × 15mm
AM2634...ZCZQ1	NFBGA (324)	15mm × 15mm
AM2632...ZCZQ1	NFBGA (324)	15mm × 15mm

- (1) 如需更多信息，请参阅节 10 机械、封装和可订购信息。
 (2) 所有器件均采用托盘或卷带包装。

3.1 功能方框图

图 3-1 展示了器件的功能方框图。

ADVANCE INFORMATION



图 3-1. 功能方框图

Table of Contents

1 特性	1	7.8 VPP Specifications for One-Time Programmable (OTP) eFuses.....	71
2 应用	2	7.9 Thermal Resistance Characteristics.....	72
3 说明	3	7.10 Timing and Switching Characteristics.....	73
3.1 功能方框图.....	4	7.11 Decoupling Capacitor Requirements.....	126
4 Revision History	5	8 Detailed Description	127
5 Device Comparison	6	8.1 Overview.....	127
5.1 Related Products.....	8	8.2 Processor Subsystems.....	128
6 Terminal Configuration and Functions	9	9 Device and Documentation Support	129
6.1 Pin Diagram.....	9	9.1 Device Nomenclature.....	129
6.2 Pin Attributes.....	11	9.2 Tools and Software.....	133
6.3 Signal Descriptions.....	37	9.3 Documentation Support.....	133
6.4 Pin Connectivity Requirements.....	62	9.4 支持资源.....	133
7 Specifications	64	9.5 Trademarks.....	133
7.1 Absolute Maximum Ratings.....	64	9.6 Electrostatic Discharge Caution.....	134
7.2 Electrostatic Discharge (ESD) Ratings.....	64	9.7 术语表.....	134
7.3 Power-On Hours (POH) Summary.....	65	10 Mechanical, Packaging, and Orderable Information	135
7.4 Recommended Operating Conditions.....	65	10.1 Packaging Information.....	135
7.5 Operating Performance Points.....	65		
7.6 Power Consumption Summary.....	66		
7.7 Electrical Characteristics.....	66		

4 Revision History

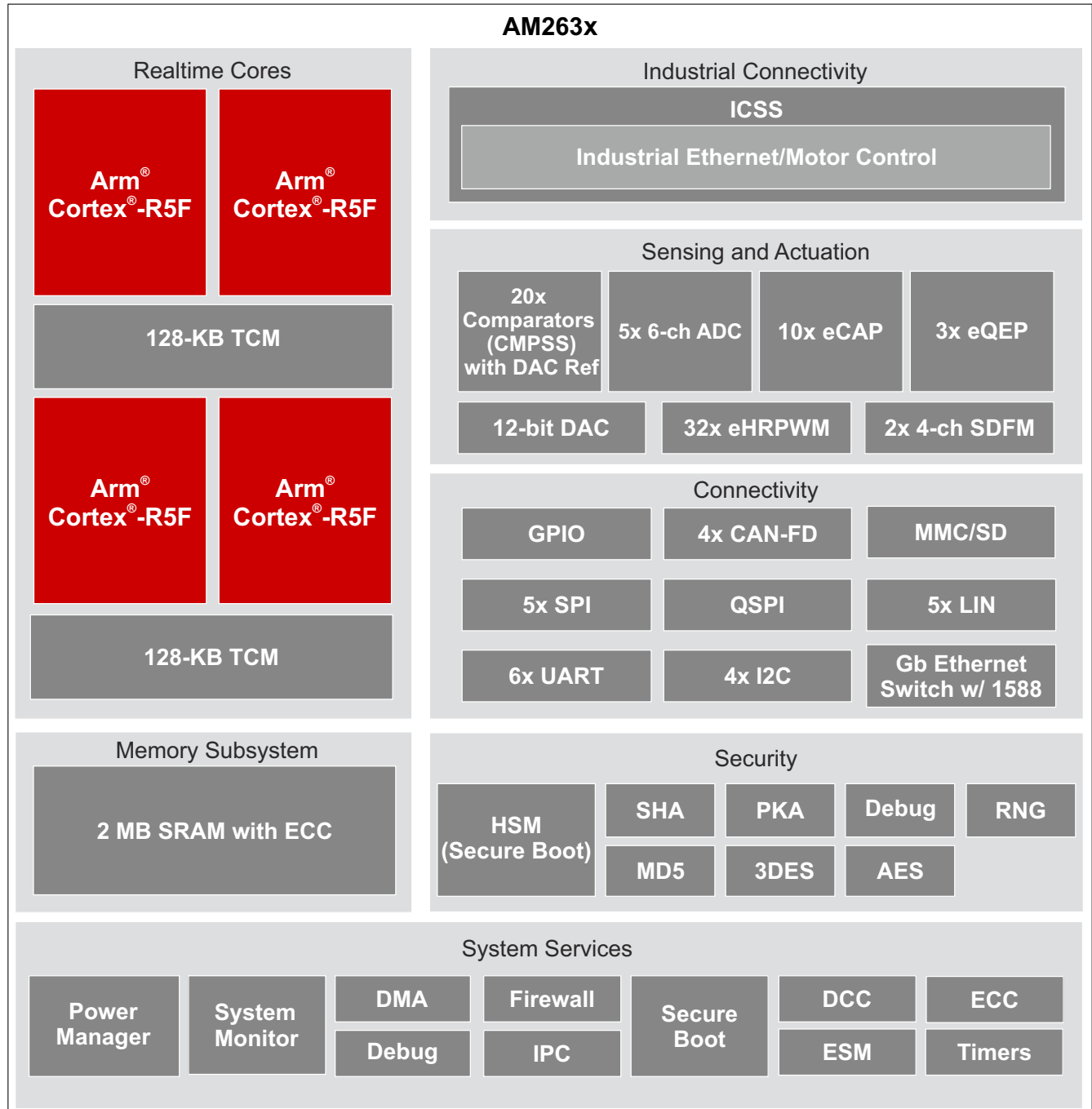
DATE	REVISION	NOTES
March 2022	*	Initial release.

5 Device Comparison

表 5-1 shows a comparison between devices, highlighting the differences.

表 5-1. Device Comparison

FEATURES	REFERENCE NAME	AM2634	AM2632	AM2631
JTAG Device ID		TBD	TBD	TBD
PROCESSORS AND ACCELERATORS				
Speed Grade		See 节 7.5, <i>Speed And Memory Grade</i>		
Arm Cortex-R5F	Arm R5F	2 x Dual Core with Lockstep	1 x Dual Core with Lockstep	Single Core
Hardware Security Module	Security	Yes		
Crypto Accelerators	Security	Yes		
PROGRAM AND DATA STORAGE				
On-Chip Shared Memory (RAM)	OCSRAM	See 节 7.5, <i>Speed And Memory Grade</i>		
R5F Tightly Coupled Memory (TCM)	TCM	256KB		
General-Purpose Memory Controller	GPMC	4MB with 16b ECC		
PERIPHERALS				
Modular Controller Area Network Interface	MCAN	4		
Full CAN-FD Support ⁽³⁾	MCAN	4-Optional	4-Optional	—
General-Purpose I/O	GPIO	Up to 140		
Serial Peripheral Interface	SPI	5		
Universal Asynchronous Receiver and Trasmmitter	UART	6		
Local Interconnect Network	LIN	5		
Inter-Integrated Circuit Interface	I2C	4		
Analog-to-Digital Converter	ADC	3 ⁽¹⁾ or 5 ⁽²⁾	3 ⁽¹⁾ or 5 ⁽²⁾	3
Comparator Modules	CMPSS	9 ⁽¹⁾ or 20 ⁽²⁾	9 ⁽¹⁾ or 20 ⁽²⁾	9
Digital-to-Analog Converter	DAC	1		
Programmable Real-Time Unit Subsystem ⁽⁴⁾	PRU_ICSS	0 or 1	0 or 1	—
Industrial Communication Subsystem Support ⁽⁵⁾	PRU_ICSS	Optional	Optional	—
Gigabit Ethernet Interface	CPSW3G	Yes (2-port)		
Multi-Media Card/Secure Digital Interface	MMCSD	1		
Enhanced High-Resolution Pulse-Width Modulator Module	EHRPWM	16 ⁽¹⁾ or 32 ⁽²⁾	16 ⁽¹⁾ or 32 ⁽²⁾	16
Enhanced Capture Module	ECAP	10		
Enhanced Quadrature Encoder Pulse Module	EQEP	2 ⁽¹⁾ or 3 ⁽²⁾	2 ⁽¹⁾ or 3 ⁽²⁾	2
Sigma Delta Filter Module	SDFM	1 ⁽¹⁾ or 2 ⁽²⁾	1 ⁽¹⁾ or 2 ⁽²⁾	1
Fast Serial Interface	FSI_RX	4		
	FSI_TX	4		
QSPI	Flash I/F	1		
Miscellaneous				
Junction Temperature	Extended Industrial	- 40°C to 105°C		
	Extended Automotive	- 40°C to 150°C		—
Automotive Qualification		AEC-Q100 ⁽⁶⁾ Option		—

- (1) Standard Analog configuration contains 3x ADCs, 16x EHRPWM, 2x EQEP, 1x SDFM, 9x CMPSS
 (2) Enhanced Analog configuration contains 5x ADC, 32x EHRPWM, 3x EQEP, 2x SDFM, 20x CMPSS
 (3) Full CAN-FD support is available when selecting an orderable part number that includes a feature code of E, F, L, or M. Refer to the [Nomenclature Description](#) table for definition of feature codes.

- (4) Programmable Real-Time Unit Subsystem is available when selecting an orderable part number that includes a feature code of D, E, F, K, L, or M. Refer to the [Nomenclature Description](#) table for definition of feature codes.
- (5) Industrial Communication Subsystem Support is available when selecting an orderable part number that includes a feature code of D, E, F, K, L, or M. Refer to the [Nomenclature Description](#) table for definition of feature codes.
- (6) AEC-Q100 qualification is applicable to select part number variants as indicated by the Automotive Designator (Q1) identifier in the [Nomenclature Description](#) table.

5.1 Related Products

Sitara™ processors Broad family of scalable processors based on Arm® Cortex®-A cores with flexible accelerators, peripherals, connectivity and unified software support - perfect for sensors to servers. Sitara processors have the reliability needed for use in industrial applications.

6 Terminal Configuration and Functions

6.1 Pin Diagram

备注

The terms "ball", "pin", and "terminal" are used interchangeably throughout the document. An attempt is made to use "ball" only when referring to the physical package.

The diagrams in this section are used in conjunction with the other Terminal Configuration and Functions tables to locate signal names and ball grid numbers.

6.1.1 AM263x ZCZ Pin Diagram

This diagram shows the ball locations for the AM263x non-lidded 324-pin New Fine Pitch Ball Grid Array (nFBGA) ZCZ package.

ADVANCE INFORMATION

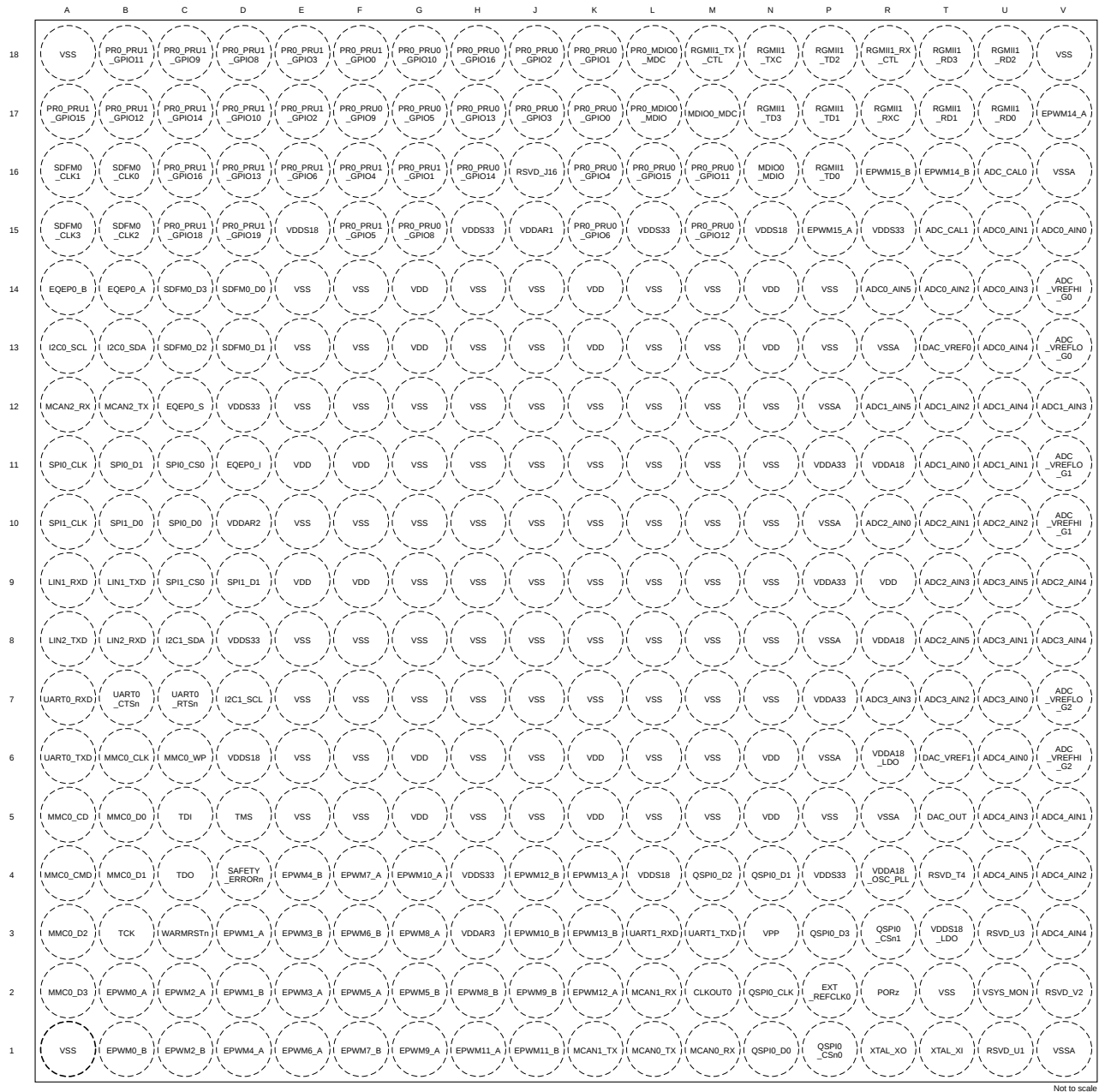

Not to scale

6.2 Pin Attributes

1. **BALL NUMBER:** Ball numbers assigned to each terminal of the Ball Grid Array package.
2. **BALL NAME:** Ball name assigned to each terminal of the Ball Grid Array package (this name is typically taken from the primary MUXMODE 0 signal function).
3. **SIGNAL NAME:** Signal name(s) of all dedicated and pin multiplexed signal functions associated with a ball.

备注

The *Pin Attributes* table, defines the pin multiplexed signal functions implemented at the pin and does not define secondary multiplexing of signal functions implemented in device subsystems. Secondary multiplexing of signal functions are not described in this table. For more information on secondary multiplexed signal functions, see the respective peripheral chapter of the device TRM.

4. **MUX MODE:** The MUXMODE value associated with each pin multiplexed signal function:
 - a. MUXMODE 0 is the primary pin multiplexed signal function. However, the primary pin multiplexed signal function is not necessarily the default pin multiplexed signal function.

备注

The value found in the MUX MODE AFTER RESET column defines the default pin multiplexed signal function selected when PORz is deasserted.

- b. MUXMODE values 1 through 15 are possible for pin multiplexed signal functions. However, not all MUXMODE values have been implemented. The only valid MUXMODE values are those defined as pin multiplexed signal functions within the Pin Attributes table. Only valid values of MUXMODE should be used.
 - c. Bootstrap/Sense On Power (SOP) pins define the SoC boot mode configuration pins, where the logic state applied to each pin is latched after the rising edge of PORz.
 - d. An empty box or "-" means Not Applicable.
5. **TYPE:** Signal type and direction:
 - I = Input
 - O = Output
 - IO = Input, Output, or simultaneously Input and Output
 - IOD = Input, Output, or simultaneously Input and Output, with open-drain output function
 - IOZ = Input, Output, or simultaneously Input and Output, with three-state output function
 - OZ = Output with three-state output function
 - A = Analog
 - PWR = Power
 - GND = Ground
 - CAP = LDO Capacitor.
6. **I/O VOLTAGE VALUE:** This column describes I/O operating voltage options of the respective power supply, when applicable.
An empty box or "-" means Not Applicable.

For more information, see valid operating voltage range(s) defined for each power supply in *Recommended Operating Conditions*.

7. **BALL STATE DURING RESET (RX/TX/PULL):** State of the terminal while PORz is asserted, where RX defines the state of the input buffer, TX defines the state of the output buffer, and PULL defines the state of internal pull resistors:
 - RX (Input buffer)
 - Off: The input buffer is disabled.
 - On: The input buffer is enabled.
 - TX (Output buffer)
 - Off: The output buffer is disabled.
 - Low: The output buffer is enabled and drives V_{OL} .
 - PULL (Internal pull resistors)

- Off: Internal pull resistors are turned off.
 - Up: Internal pull-up resistor is turned on.
 - Down: Internal pull-down resistor is turned on.
 - An empty box or "-" means Not Applicable.
8. **BALL STATE AFTER RESET (RX/TX/PULL):** State of the terminal after PORz is deasserted, where RX defines the state of the input buffer, TX defines the state of the output buffer, and PULL defines the state of internal pull resistors:
- RX (Input buffer)
 - Off: The input buffer is disabled.
 - On: The input buffer is enabled.
 - TX (Output buffer)
 - Off: The output buffer is disabled.
 - SS: The subsystem selected with MUXMODE determines the output buffer state.
 - PULL (Internal pull resistors)
 - Off: Internal pull resistors are turned off.
 - Up: Internal pull-up resistor is turned on.
 - Down: Internal pull-down resistor is turned on.
 - An empty box or "-" means Not Applicable.
9. **MUX MODE AFTER RESET:** The value found in this column defines the default pin multiplexed signal function after PORz is deasserted.
An empty box means Not Applicable.
10. **POWER:** The power supply of the associated I/O, when applicable.
An empty box or "-" means Not Applicable.
11. **HYS:** Indicates if the input buffer associated with this I/O has hysteresis:
- Yes: With hysteresis
 - No: Without hysteresis
 - An empty box or "-" means Not Applicable.
- For more information, see the hysteresis values in *Electrical Characteristics*.
12. **BUFFER TYPE:** This column defines the buffer type associated with a terminal. This information can be used to determine which Electrical Characteristics table is applicable.
An empty box or "-" means Not Applicable.
For electrical characteristics, refer to the appropriate buffer type table in *Electrical Characteristics*.
13. **PULL UP/DOWN TYPE:** Indicates the presence of an internal pullup or pulldown resistor. Pullup and pulldown resistors can be enabled or disabled via software.
- PU: Internal pull-up
 - PD: Internal pull-down
 - PU/PD: Internal pull-up and pull-down
 - An empty box or "-" means No internal pull.

备注

Configuring two pins to the same pin multiplexed signal function is not supported as it can yield unexpected results. This can be easily prevented with the proper software configuration.

备注

When a pad is set into a multiplexing mode which is not defined by pin multiplexing, that pad's behavior is undefined. This should be avoided.

14. **Pad Configuration Register Name:** This is the name of the device pad/pin configuration register.

15. **Pad Configuration Register Address:** This is the memory address of the device pad/pin configuration register.
16. **Pad Configuration Register Default Value:** This is the default value of the register device pad/pin configuration register after PORz cold reset.

表 6-1. Pin Attributes (ZCZ Package)

BALL NUMBER [1]	BALL NAME [2]/ IOMUX REGISTER [14]/ ADDRESS [15]/ DEFAULT VALUE [16]	SIGNAL NAME [3]	MUX MODE [4]	TYPE [5]	IO VOLTAGE [6]	BALL STATE DURING RESET RX/TX/PULL [7]	BALL STATE AFTER RESET RX/TX/PULL [8]	MUX MODE AFTER RESET [9]	POWER [10]	HYS [11]	BUFFER TYPE [12]	PULL TYPE [13]
V15	ADC0_AIN0	ADC0_AIN0		I	3.3V				VDDA_CIO		AnalogCIO	
U15	ADC0_AIN1	ADC0_AIN1		I	3.3V				VDDA_CIO		AnalogCIO	
T14	ADC0_AIN2	ADC0_AIN2		I	3.3V				VDDA_CIO		AnalogCIO	
U14	ADC0_AIN3	ADC0_AIN3		I	3.3V				VDDA_CIO		AnalogCIO	
U13	ADC0_AIN4	ADC0_AIN4		I	3.3V				VDDA_CIO		AnalogCIO	
R14	ADC0_AIN5	ADC0_AIN5		I	3.3V				VDDA_CIO		AnalogCIO	
T11	ADC1_AIN0	ADC1_AIN0		I	3.3V				VDDA_CIO		AnalogCIO	
U11	ADC1_AIN1	ADC1_AIN1		I	3.3V				VDDA_CIO		AnalogCIO	
T12	ADC1_AIN2	ADC1_AIN2		I	3.3V				VDDA_CIO		AnalogCIO	
V12	ADC1_AIN3	ADC1_AIN3		I	3.3V				VDDA_CIO		AnalogCIO	
U12	ADC1_AIN4	ADC1_AIN4		I	3.3V				VDDA_CIO		AnalogCIO	
R12	ADC1_AIN5	ADC1_AIN5		I	3.3V				VDDA_CIO		AnalogCIO	
R10	ADC2_AIN0	ADC2_AIN0		I	3.3V				VDDA_CIO		AnalogCIO	
T10	ADC2_AIN1	ADC2_AIN1		I	3.3V				VDDA_CIO		AnalogCIO	
U10	ADC2_AIN2	ADC2_AIN2		I	3.3V				VDDA_CIO		AnalogCIO	
T9	ADC2_AIN3	ADC2_AIN3		I	3.3V				VDDA_CIO		AnalogCIO	
V9	ADC2_AIN4	ADC2_AIN4		I	3.3V				VDDA_CIO		AnalogCIO	
T8	ADC2_AIN5	ADC2_AIN5		I	3.3V				VDDA_CIO		AnalogCIO	
U7	ADC3_AIN0	ADC3_AIN0		I	3.3V				VDDA_CIO		AnalogCIO	
U8	ADC3_AIN1	ADC3_AIN1		I	3.3V				VDDA_CIO		AnalogCIO	
T7	ADC3_AIN2	ADC3_AIN2		I	3.3V				VDDA_CIO		AnalogCIO	
R7	ADC3_AIN3	ADC3_AIN3		I	3.3V				VDDA_CIO		AnalogCIO	
V8	ADC3_AIN4	ADC3_AIN4		I	3.3V				VDDA_CIO		AnalogCIO	
U9	ADC3_AIN5	ADC3_AIN5		I	3.3V				VDDA_CIO		AnalogCIO	
U6	ADC4_AIN0	ADC4_AIN0		I	3.3V				VDDA_CIO		AnalogCIO	
V5	ADC4_AIN1	ADC4_AIN1		I	3.3V				VDDA_CIO		AnalogCIO	
V4	ADC4_AIN2	ADC4_AIN2		I	3.3V				VDDA_CIO		AnalogCIO	
U5	ADC4_AIN3	ADC4_AIN3		I	3.3V				VDDA_CIO		AnalogCIO	
V3	ADC4_AIN4	ADC4_AIN4		I	3.3V				VDDA_CIO		AnalogCIO	
U4	ADC4_AIN5	ADC4_AIN5		I	3.3V				VDDA_CIO		AnalogCIO	
U16	ADC_CAL0	ADC_CAL0		I	3.3V				VDDA_CIO		AnalogCIO	
T15	ADC_CAL1	ADC_CAL1		I	3.3V				VDDA_CIO		AnalogCIO	
V14	ADC_VREFHI_G0	ADC_VREFHISRC0		A	3.3V				VDDA_CIO		AnalogCIO	
V10	ADC_VREFHI_G1	ADC_VREFHI1		A	3.3V				VDDA_CIO		AnalogCIO	
V6	ADC_VREFHI_G2	ADC_VREFHISRC1		A	3.3V				VDDA_CIO		AnalogCIO	
V13	ADC_VREFLO_G0	ADC_VREFLOSRC0		A	3.3V				VDDA_CIO		AnalogCIO	

表 6-1. Pin Attributes (ZCZ Package) (continued)

BALL NUMBER [1]	BALL NAME [2]/ IOMUX REGISTER [14]/ ADDRESS [15]/ DEFAULT VALUE [16]	SIGNAL NAME [3]	MUX MODE [4]	TYPE [5]	IO VOLTAGE [6]	BALL STATE DURING RESET RX/TX/PULL [7]	BALL STATE AFTER RESET RX/TX/PULL [8]	MUX MODE AFTER RESET [9]	POWER [10]	HYS [11]	BUFFER TYPE [12]	PULL TYPE [13]
V11	ADC_VREFLO_G1	ADC_VREFLO1		A	3.3V				VDDA_CIO		AnalogCIO	
V7	ADC_VREFLO_G2	ADC_VREFLOSRC1		A	3.3V				VDDA_CIO		AnalogCIO	
M2	CLKOUT0 CLKOUT0_CFG_REG 0x5310 0228 0x0000 0570	CLKOUT0	0	O	3.3 V	Off / Off / Off	Off / SS / Off	0	VDDSHV0	Yes	LVCMOS	PU/PD
		GPIO138	7	IO								
T5	DAC_OUT	DAC_OUT		O	3.3V				VDDA_CIO		AnalogCIO	
T13	DAC_VREF0	DAC_VREF0		A	3.3V				VDDA_CIO		AnalogCIO	
T6	DAC_VREF1	DAC_VREF1		A	3.3V				VDDA_CIO		AnalogCIO	
B2	EPWM0_A EPWM0_A_CFG_REG 0x5310 00AC 0x0000 05F7	EPWM0_A	0	O	3.3 V	Off / Off / Off	Off / Off / Off	7	VDDSHV0	Yes	LVCMOS	PU/PD
		GPIO43	7	IO								
B1	EPWM0_B EPWM0_B_CFG_REG 0x5310 00B0 0x0000 05F7	EPWM0_B	0	O	3.3 V	Off / Off / Off	Off / Off / Off	7	VDDSHV0	Yes	LVCMOS	PU/PD
		GPIO44	7	IO								
D3	EPWM1_A EPWM1_A_CFG_REG 0x5310 00B4 0x0000 05F7	EPWM1_A	0	O	3.3 V	Off / Off / Off	Off / Off / Off	7	VDDSHV0	Yes	LVCMOS	PU/PD
		GPIO45	7	IO								
D2	EPWM1_B EPWM1_B_CFG_REG 0x5310 00B8 0x0000 05F7	EPWM1_B	0	O	3.3 V	Off / Off / Off	Off / Off / Off	7	VDDSHV0	Yes	LVCMOS	PU/PD
		GPIO46	7	IO								
C2	EPWM2_A EPWM2_A_CFG_REG 0x5310 00BC 0x0000 05F7	EPWM2_A	0	O	3.3 V	Off / Off / Off	Off / Off / Off	7	VDDSHV0	Yes	LVCMOS	PU/PD
		GPIO47	7	IO								
C1	EPWM2_B EPWM2_B_CFG_REG 0x5310 00C0 0x0000 05F7	EPWM2_B	0	O	3.3 V	Off / Off / Off	Off / Off / Off	7	VDDSHV0	Yes	LVCMOS	PU/PD
		GPIO48	7	IO								
E2	EPWM3_A EPWM3_A_CFG_REG 0x5310 00C4 0x0000 05F7	EPWM3_A	0	O	3.3 V	Off / Off / Off	Off / Off / Off	7	VDDSHV0	Yes	LVCMOS	PU/PD
		GPIO49	7	IO								
E3	EPWM3_B EPWM3_B_CFG_REG 0x5310 00C8 0x0000 05F7	EPWM3_B	0	O	3.3 V	Off / Off / Off	Off / Off / Off	7	VDDSHV0	Yes	LVCMOS	PU/PD
		GPIO50	7	IO								
D1	EPWM4_A EPWM4_A_CFG_REG 0x5310 00CC 0x0000 05F7	EPWM4_A	0	O	3.3 V	Off / Off / Off	Off / Off / Off	7	VDDSHV0	Yes	LVCMOS	PU/PD
		GPIO51	7	IO								

表 6-1. Pin Attributes (ZCZ Package) (continued)

BALL NUMBER [1]	BALL NAME [2]/ IOMUX REGISTER [14]/ ADDRESS [15]/ DEFAULT VALUE [16]	SIGNAL NAME [3]	MUX MODE [4]	TYPE [5]	IO VOLTAGE [6]	BALL STATE DURING RESET RX/TX/PULL [7]	BALL STATE AFTER RESET RX/TX/PULL [8]	MUX MODE AFTER RESET [9]	POWER [10]	HYS [11]	BUFFER TYPE [12]	PULL TYPE [13]
E4	EPWM4_B EPWM4_B_CFG_REG 0x5310 00D0 0x0000 05F7	EPWM4_B	0	O	3.3 V	Off / Off / Off	Off / Off / Off	7	VDDSHV0	Yes	LVCMOS	PU/PD
		FSITX1_CLK	6	O								
		GPIO52	7	IO								
F2	EPWM5_A_CFG_REG 0x5310 00D4 0x0000 05F7	EPWM5_A	0	O	3.3 V	Off / Off / Off	Off / Off / Off	7	VDDSHV0	Yes	LVCMOS	PU/PD
		FSITX1_DATA0	6	O								
		GPIO53	7	IO								
G2	EPWM5_B_CFG_REG 0x5310 00D8 0x0000 05F7	EPWM5_B	0	O	3.3 V	Off / Off / Off	Off / Off / Off	7	VDDSHV0	Yes	LVCMOS	PU/PD
		FSITX1_DATA1	6	O								
		GPIO54	7	IO								
E1	EPWM6_A_CFG_REG 0x5310 00DC 0x0000 05F7	EPWM6_A	0	O	3.3 V	Off / Off / Off	Off / Off / Off	7	VDDSHV0	Yes	LVCMOS	PU/PD
		FSIRX1_CLK	6	I								
		GPIO55	7	IO								
F3	EPWM6_B_CFG_REG 0x5310 00E0 0x0000 05F7	EPWM6_B	0	O	3.3 V	Off / Off / Off	Off / Off / Off	7	VDDSHV0	Yes	LVCMOS	PU/PD
		FSIRX1_DATA0	6	I								
		GPIO56	7	IO								
F4	EPWM7_A_CFG_REG 0x5310 00E4 0x0000 05F7	EPWM7_A	0	O	3.3 V	Off / Off / Off	Off / Off / Off	7	VDDSHV0	Yes	LVCMOS	PU/PD
		FSIRX1_DATA1	6	I								
		GPIO57	7	IO								
F1	EPWM7_B_CFG_REG 0x5310 00E8 0x0000 05F7	EPWM7_B	0	O	3.3 V	Off / Off / Off	Off / Off / Off	7	VDDSHV0	Yes	LVCMOS	PU/PD
		GPIO58	7	IO								
G3	EPWM8_A_CFG_REG 0x5310 00EC 0x0000 05F7	EPWM8_A	0	O	3.3 V	Off / Off / Off	Off / Off / Off	7	VDDSHV0	Yes	LVCMOS	PU/PD
		UART4_TXD	1	O								
		I2C3_SDA	2	IO								
		FSITX2_CLK	6	O								
		GPIO59	7	IO								
H2	EPWM8_B_CFG_REG 0x5310 00F0 0x0000 05F7	EPWM8_B	0	O	3.3 V	Off / Off / Off	Off / Off / Off	7	VDDSHV0	Yes	LVCMOS	PU/PD
		UART4_RXD	1	I								
		I2C3_SCL	2	IO								
		FSITX2_DATA0	6	O								
		GPIO60	7	IO								
G1	EPWM9_A_CFG_REG 0x5310 00F4 0x0000 05F7	EPWM9_A	0	O	3.3 V	Off / Off / Off	Off / Off / Off	7	VDDSHV0	Yes	LVCMOS	PU/PD
		FSITX2_DATA1	6	O								
		GPIO61	7	IO								

表 6-1. Pin Attributes (ZCZ Package) (continued)

BALL NUMBER [1]	BALL NAME [2]/ IOMUX REGISTER [14]/ ADDRESS [15]/ DEFAULT VALUE [16]	SIGNAL NAME [3]	MUX MODE [4]	TYPE [5]	IO VOLTAGE [6]	BALL STATE DURING RESET RX/TX/PULL [7]	BALL STATE AFTER RESET RX/TX/PULL [8]	MUX MODE AFTER RESET [9]	POWER [10]	HYS [11]	BUFFER TYPE [12]	PULL TYPE [13]
J2	EPWM9_B EPWM9_B_CFG_REG 0x5310 00F8 0x0000 05F7	EPWM9_B	0	O	3.3 V	Off / Off / Off	Off / Off / Off	7	VDDSHV0	Yes	LVCMOS	PU/PD
		UART1_RTSn	1	O								
		FSIRX2_CLK	6	I								
		GPIO62	7	IO								
G4	EPWM10_A EPWM10_A_CFG_REG 0x5310 00FC 0x0000 05F7	EPWM10_A	0	O	3.3 V	Off / Off / Off	Off / Off / Off	7	VDDSHV0	Yes	LVCMOS	PU/PD
		UART1_CTSn	1	I								
		FSIRX2_DATA0	6	I								
		GPIO63	7	IO								
J3	EPWM10_B EPWM10_B_CFG_REG 0x5310 0100 0x0000 05F7	EPWM10_B	0	O	3.3 V	Off / Off / Off	Off / Off / Off	7	VDDSHV0	Yes	LVCMOS	PU/PD
		UART2_RTSn	1	O								
		FSIRX2_DATA1	6	I								
		GPIO64	7	IO								
H1	EPWM11_A EPWM11_A_CFG_REG 0x5310 0104 0x0000 05F7	EPWM11_A	0	O	3.3 V	Off / Off / Off	Off / Off / Off	7	VDDSHV0	Yes	LVCMOS	PU/PD
		UART2_CTSn	1	I								
		GPMC0_CLKLB	6	IO								
		GPIO65	7	IO								
J1	EPWM11_B EPWM11_B_CFG_REG 0x5310 0108 0x0000 05F7	EPWM11_B	0	O	3.3 V	Off / Off / Off	Off / Off / Off	7	VDDSHV0	Yes	LVCMOS	PU/PD
		UART3_RTSn	1	O								
		GPMC0_OEn_REn	6	O								
		GPIO66	7	IO								
K2	EPWM12_A EPWM12_A_CFG_REG 0x5310 010C 0x0000 05F7	EPWM12_A	0	O	3.3 V	Off / Off / Off	Off / Off / Off	7	VDDSHV0	Yes	LVCMOS	PU/PD
		UART3_CTSn	1	I								
		SPI4_CS1	2	IO								
		GPMC0_WEn	6	O								
		GPIO67	7	IO								
J4	EPWM12_B EPWM12_B_CFG_REG 0x5310 0110 0x0000 05F7	EPWM12_B	0	O	3.3 V	Off / Off / Off	Off / Off / Off	7	VDDSHV0	Yes	LVCMOS	PU/PD
		UART1_DCDn	1	I								
		GPMC0_CSn0	6	O								
		GPIO68	7	IO								
K4	EPWM13_A EPWM13_A_CFG_REG 0x5310 0114 0x0000 05F7	EPWM13_A	0	O	3.3 V	Off / Off / Off	Off / Off / Off	7	VDDSHV0	Yes	LVCMOS	PU/PD
		UART1_RIn	1	I								
		GPMC0_AD0	6	IO								
		GPIO69	7	IO								
K3	EPWM13_B EPWM13_B_CFG_REG 0x5310 0118 0x0000 05F7	EPWM13_B	0	O	3.3 V	Off / Off / Off	Off / Off / Off	7	VDDSHV0	Yes	LVCMOS	PU/PD
		UART1_DTRn	1	O								
		GPMC0_AD1	6	IO								
		GPIO70	7	IO								

表 6-1. Pin Attributes (ZCZ Package) (continued)

BALL NUMBER [1]	BALL NAME [2]/ IOMUX REGISTER [14]/ ADDRESS [15]/ DEFAULT VALUE [16]	SIGNAL NAME [3]	MUX MODE [4]	TYPE [5]	IO VOLTAGE [6]	BALL STATE DURING RESET RX/TX/PULL [7]	BALL STATE AFTER RESET RX/TX/PULL [8]	MUX MODE AFTER RESET [9]	POWER [10]	HYS [11]	BUFFER TYPE [12]	PULL TYPE [13]
V17	EPWM14_A EPWM14_A_CFG_REG 0x5310 011C 0x0000 05F7	EPWM14_A	0	O	3.3 V	Off / Off / Off	Off / Off / Off	7	VDDSHV0	Yes	LVCMOS	PU/PD
		UART1_DSRn	1	I								
		GPMC0_AD2	6	IO								
		GPIO71	7	IO								
T16	EPWM14_B EPWM14_B_CFG_REG 0x5310 0120 0x0000 05F7	EPWM14_B	0	O	3.3 V	Off / Off / Off	Off / Off / Off	7	VDDSHV0	Yes	LVCMOS	PU/PD
		MII1_RX_ER	2	I								
		GPMC0_AD3	6	IO								
		GPIO72	7	IO								
P15	EPWM15_A EPWM15_A_CFG_REG 0x5310 0124 0x0000 05F7	EPWM15_A	0	O	3.3 V	Off / Off / Off	Off / Off / Off	7	VDDSHV0	Yes	LVCMOS	PU/PD
		UART5_TXD	1	O								
		MII1_COL	2	I								
		GPMC0_AD4	6	IO								
		GPIO73	7	IO								
R16	EPWM15_B EPWM15_B_CFG_REG 0x5310 0128 0x0000 05F7	EPWM15_B	0	O	3.3 V	Off / Off / Off	Off / Off / Off	7	VDDSHV0	Yes	LVCMOS	PU/PD
		UART5_RXD	1	I								
		MII1_CRCS	2	I								
		GPMC0_AD5	6	IO								
		GPIO74	7	IO								
B14	EQEP0_A EQEP0_A_CFG_REG 0x5310 0208 0x0000 05F7	UART4_RTSn	0	O	3.3 V	Off / Off / Off	Off / Off / Off	7	VDDSHV0	Yes	LVCMOS	PU/PD
		SPI4_CLK	3	IO								
		GPIO130	7	IO								
		EQEP0_A	8	I								
		SDFM1_CLK0	9	I								
A14	EQEP0_B EQEP0_B_CFG_REG 0x5310 020C 0x0000 05F7	UART4_CTSn	0	I	3.3 V	Off / Off / Off	Off / Off / Off	7	VDDSHV0	Yes	LVCMOS	PU/PD
		SPI4_CS0	3	IO								
		GPIO131	7	IO								
		EQEP0_B	8	I								
		SDFM1_D0	9	I								
D11	EQEP0_I EQEP0_I_CFG_REG 0x5310 0214 0x0000 05F7	UART4_RXD	0	I	3.3 V	Off / Off / Off	Off / Off / Off	7	VDDSHV0	Yes	LVCMOS	PU/PD
		LIN4_RXD	1	IO								
		SPI4_D1	3	IO								
		GPIO133	7	IO								
		EQEP0_I	8	IO								
		SDFM1_D1	9	I								

表 6-1. Pin Attributes (ZCZ Package) (continued)

BALL NUMBER [1]	BALL NAME [2]/ IOMUX REGISTER [14]/ ADDRESS [15]/ DEFAULT VALUE [16]	SIGNAL NAME [3]	MUX MODE [4]	TYPE [5]	IO VOLTAGE [6]	BALL STATE DURING RESET RX/TX/PULL [7]	BALL STATE AFTER RESET RX/TX/PULL [8]	MUX MODE AFTER RESET [9]	POWER [10]	HYS [11]	BUFFER TYPE [12]	PULL TYPE [13]
C12	EQEP0_S EQEP0_S_CFG_REG 0x5310 0210 0x0000 05F7	UART4_TXD	0	O	3.3 V	Off / Off / Off	Off / Off / Off	7	VDDSHV0	Yes	LVCMOS	PU/PD
		LIN4_TXD	1	IO								
		SPI4_D0	3	IO								
		GPIO132	7	IO								
		EQEP0_S	8	IO								
		SDFM1_CLK1	9	I								
P2	EXT_REFCLK0 EXT_REFCLK0_CFG_REG 0x5310 01E4 0x0000 05F7	EXT_REFCLK0	0	I	3.3 V	Off / Off / Off	Off / Off / Off	7	VDDSHV0	Yes	LVCMOS	PU/PD
		XBAROUT15	5	O								
		GPIO121	7	IO								
		EQEP1_I	9	IO								
A13	I2C0_SCL I2C0_SCL_CFG_REG 0x5310 021C 0x0000 05F7	I2C0_SCL	0	IO	3.3 V	Off / Off / Off	Off / Off / Off	7	VDDSHV0	Yes	I2C OD	
		GPIO135	7	IO								
		EQEP2_B	8	I								
		SDFM1_CLK3	9	I								
B13	I2C0_SDA I2C0_SDA_CFG_REG 0x5310 0218 0x0000 05F7	I2C0_SDA	0	IO	3.3 V	Off / Off / Off	Off / Off / Off	7	VDDSHV0	Yes	I2C OD	
		GPIO134	7	IO								
		EQEP2_A	8	I								
		SDFM1_CLK2	9	I								
D7	I2C1_SCL I2C1_SCL_CFG_REG 0x5310 005C 0x0000 05F7	I2C1_SCL	0	IO	3.3 V	Off / Off / Off	Off / Off / Off	7	VDDSHV0	Yes	LVCMOS	PU/PD
		SPI3_CS0	2	IO								
		XBAROUT7	5	O								
		GPIO23	7	IO								
C8	I2C1_SDA I2C1_SDA_CFG_REG 0x5310 0060 0x0000 05F7	I2C1_SDA	0	IO	3.3 V	Off / Off / Off	Off / Off / Off	7	VDDSHV0	Yes	LVCMOS	PU/PD
		SPI3_CLK	2	IO								
		XBAROUT8	5	O								
		GPIO24	7	IO								
A9	LIN1_RXD LIN1_RXD_CFG_REG 0x5310 004C 0x0000 05F7	LIN1_RXD	0	IO	3.3 V	Off / Off / Off	Off / Off / Off	7	VDDSHV0	Yes	LVCMOS	PU/PD
		UART1_RXD	1	I								
		SPI2_CS0	2	IO								
		XBAROUT5	5	O								
		GPIO19	7	IO								
B9	LIN1_TXD LIN1_TXD_CFG_REG 0x5310 0050 0x0000 05F7	LIN1_TXD	0	IO	3.3 V	Off / Off / Off	Off / Off / Off	7	VDDSHV0	Yes	LVCMOS	PU/PD
		UART1_TXD	1	O								
		SPI2_CLK	2	IO								
		XBAROUT6	5	O								
		GPIO20	7	IO								

表 6-1. Pin Attributes (ZCZ Package) (continued)

BALL NUMBER [1]	BALL NAME [2]/ IOMUX REGISTER [14]/ ADDRESS [15]/ DEFAULT VALUE [16]	SIGNAL NAME [3]	MUX MODE [4]	TYPE [5]	IO VOLTAGE [6]	BALL STATE DURING RESET RX/TX/PULL [7]	BALL STATE AFTER RESET RX/TX/PULL [8]	MUX MODE AFTER RESET [9]	POWER [10]	HYS [11]	BUFFER TYPE [12]	PULL TYPE [13]
B8	LIN2_RXD LIN2_RXD_CFG_REG 0x5310 0054 0x0000 05F7	LIN2_RXD	0	IO	3.3 V	Off / Off / Off	Off / Off / Off	7	VDDSHV0	Yes	LVCMOS	PU/PD
		UART2_RXD	1	I								
		SPI2_D0	2	IO								
		GPIO21	7	IO								
A8	LIN2_TXD LIN2_TXD_CFG_REG 0x5310 0058 0x0000 05F7	LIN2_TXD	0	IO	3.3 V	Off / Off / Off	Off / Off / Off	7	VDDSHV0	Yes	LVCMOS	PU/PD
		UART2_TXD	1	O								
		SPI2_D1	2	IO								
		GPIO22	7	IO								
M1	MCAN0_RX MCAN0_RX_CFG_REG 0x5310 001C 0x0000 05F7	MCAN0_RX	0	I	3.3 V	Off / Off / Off	Off / Off / Off	7	VDDSHV0	Yes	LVCMOS	PU/PD
		SPI4_CS0	1	IO								
		GPIO7	7	IO								
L1	MCAN0_TX MCAN0_TX_CFG_REG 0x5310 0020 0x0000 05F7	MCAN0_TX	0	O	3.3 V	Off / Off / Off	Off / Off / Off	7	VDDSHV0	Yes	LVCMOS	PU/PD
		SPI4_CLK	1	IO								
		GPIO8	7	IO								
L2	MCAN1_RX MCAN1_RX_CFG_REG 0x5310 0024 0x0000 05F7	MCAN1_RX	0	I	3.3 V	Off / Off / Off	Off / Off / Off	7	VDDSHV0	Yes	LVCMOS	PU/PD
		SPI4_D0	1	IO								
		GPIO9	7	IO								
K1	MCAN1_TX MCAN1_TX_CFG_REG 0x5310 0028 0x0000 05F7	MCAN1_TX	0	O	3.3 V	Off / Off / Off	Off / Off / Off	7	VDDSHV0	Yes	LVCMOS	PU/PD
		SPI4_D1	1	IO								
		GPIO10	7	IO								
A12	MCAN2_RX MCAN2_RX_CFG_REG 0x5310 0224 0x0000 05F7	MCAN2_RX	0	I	3.3 V	Off / Off / Off	Off / Off / Off	7	VDDSHV0	Yes	LVCMOS	PU/PD
		UART2_RTSn	1	O								
		GPIO137	7	IO								
		EQEP2_I	8	IO								
		SDFM1_D3	9	I								
B12	MCAN2_TX MCAN2_TX_CFG_REG 0x5310 0220 0x0000 05F7	MCAN2_TX	0	O	3.3 V	Off / Off / Off	Off / Off / Off	7	VDDSHV0	Yes	LVCMOS	PU/PD
		UART1_RTSn	1	O								
		GPIO136	7	IO								
		EQEP2_S	8	IO								
		SDFM1_D2	9	I								
M17	MDIO0_MDC MDIO0_MDC_CFG_REG 0x5310 00A8 0x0000 05F7	MDIO0_MDC	0	O	3.3 V	Off / Off / Off	Off / Off / Off	7	VDDSHV0	Yes	LVCMOS	PU/PD
		GPIO42	7	IO								
N16	MDIO0_MDIO MDIO0_MDIO_CFG_REG 0x5310 00A4 0x0000 05F7	MDIO0_MDIO	0	IO	3.3 V	Off / Off / Off	Off / Off / Off	7	VDDSHV0	Yes	LVCMOS	PU/PD
		GPIO41	7	IO								

表 6-1. Pin Attributes (ZCZ Package) (continued)

BALL NUMBER [1]	BALL NAME [2]/ IOMUX REGISTER [14]/ ADDRESS [15]/ DEFAULT VALUE [16]	SIGNAL NAME [3]	MUX MODE [4]	TYPE [5]	IO VOLTAGE [6]	BALL STATE DURING RESET RX/TX/PULL [7]	BALL STATE AFTER RESET RX/TX/PULL [8]	MUX MODE AFTER RESET [9]	POWER [10]	HYS [11]	BUFFER TYPE [12]	PULL TYPE [13]
A5	MMC0_CD MMC0_CD_CFG_REG 0x5310 0150 0x0000 05F7	MMC0_CD	0	I	3.3 V	Off / Off / Off	Off / Off / Off	7	VDDSHV0	Yes	LVCMOS	PU/PD
		UART0_CTSn	1	I								
		I2C2_SDA	2	IO								
		EPWM20_B	5	O								
		GPMC0_AD15	6	IO								
		GPIO84	7	IO								
		SDFM1_D3	8	I								
B6	MMC0_CLK MMC0_CLK_CFG_REG 0x5310 0134 0x0000 05F7	MMC0_CLK	0	IO	3.3 V	Off / Off / Off	Off / Off / Off	7	VDDSHV0	Yes	LVCMOS	PU/PD
		UART0_RXD	1	I								
		LIN0_RXD	2	IO								
		EPWM17_A	5	O								
		GPMC0_AD8	6	IO								
		GPIO77	7	IO								
		SDFM1_CLK0	8	I								
A4	MMC0_CMD MMC0_CMD_CFG_REG 0x5310 0138 0x0000 05F7	MMC0_CMD	0	IO	3.3 V	Off / Off / Off	Off / Off / Off	7	VDDSHV0	Yes	LVCMOS	PU/PD
		UART0_TXD	1	O								
		LIN0_TXD	2	IO								
		EPWM17_B	5	O								
		GPMC0_AD9	6	IO								
		GPIO78	7	IO								
		SDFM1_D0	8	I								
C6	MMC0_WP MMC0_WP_CFG_REG 0x5310 014C 0x0000 05F7	MMC0_WP	0	I	3.3 V	Off / Off / Off	Off / Off / Off	7	VDDSHV0	Yes	LVCMOS	PU/PD
		UART0_RTSn	1	O								
		I2C2_SCL	2	IO								
		EPWM20_A	5	O								
		GPMC0_AD14	6	IO								
		GPIO83	7	IO								
		SDFM1_CLK3	8	I								
B5	MMC0_D0 MMC0_D0_CFG_REG 0x5310 013C 0x0000 05F7	MMC0_D0	0	IO	3.3 V	Off / Off / Off	Off / Off / Off	7	VDDSHV0	Yes	LVCMOS	PU/PD
		UART2_RXD	1	I								
		I2C1_SCL	2	IO								
		EPWM18_A	5	O								
		GPMC0_AD10	6	IO								
		GPIO79	7	IO								
		SDFM1_CLK1	8	I								

表 6-1. Pin Attributes (ZCZ Package) (continued)

BALL NUMBER [1]	BALL NAME [2]/ IOMUX REGISTER [14]/ ADDRESS [15]/ DEFAULT VALUE [16]	SIGNAL NAME [3]	MUX MODE [4]	TYPE [5]	IO VOLTAGE [6]	BALL STATE DURING RESET RX/TX/PULL [7]	BALL STATE AFTER RESET RX/TX/PULL [8]	MUX MODE AFTER RESET [9]	POWER [10]	HYS [11]	BUFFER TYPE [12]	PULL TYPE [13]
B4	MMC0_D1 MMC0_D1_CFG_REG 0x5310 0140 0x0000 05F7	MMC0_D1	0	IO	3.3 V	Off / Off / Off	Off / Off / Off	7	VDDSHV0	Yes	LVCMOS	PU/PD
		EPWM18_B	5	O								
		GPMC0_AD11	6	IO								
		GPIO80	7	IO								
		SDFM1_D1	8	I								
A3	MMC0_D2 MMC0_D2_CFG_REG 0x5310 0144 0x0000 05F7	MMC0_D2	0	IO	3.3 V	Off / Off / Off	Off / Off / Off	7	VDDSHV0	Yes	LVCMOS	PU/PD
		UART2_TXD	1	O								
		I2C1_SDA	2	IO								
		EPWM19_A	5	O								
		GPMC0_AD12	6	IO								
		GPIO81	7	IO								
		SDFM1_CLK2	8	I								
A2	MMC0_D3 MMC0_D3_CFG_REG 0x5310 0148 0x0000 05F7	MMC0_D3	0	IO	3.3 V	Off / Off / Off	Off / Off / Off	7	VDDSHV0	Yes	LVCMOS	PU/PD
		UART3_RTSn	1	O								
		EPWM19_B	5	O								
		GPMC0_AD13	6	IO								
		GPIO82	7	IO								
		SDFM1_D2	8	I								
R2	PORz	PORz		I	3.3 V			0	VDDSHV0	Yes	RESET	
L18	PR0_MDIO0_MDC PR0_MDIO0_MDC_CFG_REG 0x5310 0158 0x0000 05F7	PR0_MDIO0_MDC	0	O	3.3 V	Off / Off / Off	Off / Off / Off	7	VDDSHV0	Yes	LVCMOS	PU/PD
		EPWM21_B	5	O								
		GPMC0_CSn3	6	O								
		GPIO86	7	IO								
L17	PR0_MDIO0_MDIO PR0_MDIO0_MDIO_CFG_REG 0x5310 0154 0x0000 05F7	PR0_MDIO0_MDIO	0	IO	3.3 V	Off / Off / Off	Off / Off / Off	7	VDDSHV0	Yes	LVCMOS	PU/PD
		EPWM21_A	5	O								
		GPMC0_CSn2	6	O								
		GPIO85	7	IO								
K17	PR0_PRU0_GPIO0 PR0_PRU0_GPIO0_CFG_REG 0x5310 0174 0x0000 05F7	PR0_PRU0_GPIO0	0	IO	3.3 V	Off / Off / Off	Off / Off / Off	7	VDDSHV0	Yes	LVCMOS	PU/PD
		RMII2_RXD0	2	I								
		RGII2_RD0	3	I								
		MII2_RXD0	4	I								
		EPWM25_A	5	O								
		GPMC0_A1	6	O								
		GPIO93	7	IO								

表 6-1. Pin Attributes (ZCZ Package) (continued)

BALL NUMBER [1]	BALL NAME [2]/ IOMUX REGISTER [14]/ ADDRESS [15]/ DEFAULT VALUE [16]	SIGNAL NAME [3]	MUX MODE [4]	TYPE [5]	IO VOLTAGE [6]	BALL STATE DURING RESET RX/TX/PULL [7]	BALL STATE AFTER RESET RX/TX/PULL [8]	MUX MODE AFTER RESET [9]	POWER [10]	HYS [11]	BUFFER TYPE [12]	PULL TYPE [13]
K18	PR0_PRU0_GPIO1 PR0_PRU0_GPIO1_CFG_REG 0x5310 0178 0x0000 05F7	PR0_PRU0_GPIO1	0	IO	3.3 V	Off / Off / Off	Off / Off / Off	7	VDDSHV0	Yes	LVCMOS	PU/PD
		RMII2_RXD1	2	I								
		RGMI2_RD1	3	I								
		MII2_RXD1	4	I								
		EPWM25_B	5	O								
		GPMC0_A2	6	O								
		GPIO94	7	IO								
J18	PR0_PRU0_GPIO2 PR0_PRU0_GPIO2_CFG_REG 0x5310 017C 0x0000 05F7	PR0_PRU0_GPIO2	0	IO	3.3 V	Off / Off / Off	Off / Off / Off	7	VDDSHV0	Yes	LVCMOS	PU/PD
		RGMI2_RD2	3	I								
		MII2_RXD2	4	I								
		EPWM26_A	5	O								
		GPMC0_A3	6	O								
		GPIO95	7	IO								
J17	PR0_PRU0_GPIO3 PR0_PRU0_GPIO3_CFG_REG 0x5310 0180 0x0000 05F7	PR0_PRU0_GPIO3	0	IO	3.3 V	Off / Off / Off	Off / Off / Off	7	VDDSHV0	Yes	LVCMOS	PU/PD
		RGMI2_RD3	3	I								
		MII2_RXD3	4	I								
		EPWM26_B	5	O								
		GPMC0_A4	6	O								
		GPIO96	7	IO								
K16	PR0_PRU0_GPIO4 PR0_PRU0_GPIO4_CFG_REG 0x5310 0170 0x0000 05F7	PR0_PRU0_GPIO4	0	IO	3.3 V	Off / Off / Off	Off / Off / Off	7	VDDSHV0	Yes	LVCMOS	PU/PD
		RGMI2_RX_CTL	3	I								
		MII2_RXDV	4	I								
		EPWM24_B	5	O								
		GPMC0_A0	6	O								
		GPIO92	7	IO								
G17	PR0_PRU0_GPIO5 PR0_PRU0_GPIO5_CFG_REG 0x5310 015C 0x0000 05F7	PR0_PRU0_GPIO5	0	IO	3.3 V	Off / Off / Off	Off / Off / Off	7	VDDSHV0	Yes	LVCMOS	PU/PD
		RMII2_RX_ER	2	I								
		MII2_RX_ER	4	I								
		EPWM22_A	5	O								
		GPMC0_DIR	6	O								
		GPIO87	7	IO								

表 6-1. Pin Attributes (ZCZ Package) (continued)

BALL NUMBER [1]	BALL NAME [2]/ IOMUX REGISTER [14]/ ADDRESS [15]/ DEFAULT VALUE [16]	SIGNAL NAME [3]	MUX MODE [4]	TYPE [5]	IO VOLTAGE [6]	BALL STATE DURING RESET RX/TX/PULL [7]	BALL STATE AFTER RESET RX/TX/PULL [8]	MUX MODE AFTER RESET [9]	POWER [10]	HYS [11]	BUFFER TYPE [12]	PULL TYPE [13]
K15	PR0_PRU0_GPIO6 PR0_PRU0_GPIO6_CFG_REG 0x5310 016C 0x0000 05F7	PR0_PRU0_GPIO6	0	IO	3.3 V	Off / Off / Off	Off / Off / Off	7	VDDSHV0	Yes	LVCMOS	PU/PD
		RMII2_REF_CLK	2	IO								
		RGMI2_RXC	3	I								
		MII2_RXCLK	4	I								
		EPWM24_A	5	O								
		GPMC0_CSn1	6	O								
		GPIO91	7	IO								
G15	PR0_PRU0_GPIO8 PR0_PRU0_GPIO8_CFG_REG 0x5310 0168 0x0000 05F7	PR0_PRU0_GPIO8	0	IO	3.3 V	Off / Off / Off	Off / Off / Off	7	VDDSHV0	Yes	LVCMOS	PU/PD
		EPWM23_B	5	O								
		GPMC0_WPn	6	O								
		GPIO90	7	IO								
F17	PR0_PRU0_GPIO9 PR0_PRU0_GPIO9_CFG_REG 0x5310 0160 0x0000 05F7	PR0_PRU0_GPIO9	0	IO	3.3 V	Off / Off / Off	Off / Off / Off	7	VDDSHV0	Yes	LVCMOS	PU/PD
		PR0_UART0_CTSn	3	I								
		MII2_COL	4	I								
		EPWM22_B	5	O								
		GPMC0_CLK	6	IO								
		GPIO88	7	IO								
G18	PR0_PRU0_GPIO10 PR0_PRU0_GPIO10_CFG_REG 0x5310 0164 0x0000 05F7	PR0_PRU0_GPIO10	0	IO	3.3 V	Off / Off / Off	Off / Off / Off	7	VDDSHV0	Yes	LVCMOS	PU/PD
		RMII2_CRSDV	2	I								
		PR0_UART0_RTSn	3	O								
		MII2_CRSDV	4	I								
		EPWM23_A	5	O								
		GPMC0_WAIT0	6	I								
		GPIO89	7	IO								
M16	PR0_PRU0_GPIO11 PR0_PRU0_GPIO11_CFG_REG 0x5310 018C 0x0000 05F7	PR0_PRU0_GPIO11	0	IO	3.3 V	Off / Off / Off	Off / Off / Off	7	VDDSHV0	Yes	LVCMOS	PU/PD
		RMII2_TXD0	2	O								
		RGMI2_TD0	3	O								
		MII2_TXD0	4	O								
		EPWM28_A	5	O								
		GPMC0_A7	6	O								
		GPIO99	7	IO								

ADVANCE INFORMATION

表 6-1. Pin Attributes (ZCZ Package) (continued)

BALL NUMBER [1]	BALL NAME [2]/ IOMUX REGISTER [14]/ ADDRESS [15]/ DEFAULT VALUE [16]	SIGNAL NAME [3]	MUX MODE [4]	TYPE [5]	IO VOLTAGE [6]	BALL STATE DURING RESET RX/TX/PULL [7]	BALL STATE AFTER RESET RX/TX/PULL [8]	MUX MODE AFTER RESET [9]	POWER [10]	HYS [11]	BUFFER TYPE [12]	PULL TYPE [13]
M15	PR0_PRU0_GPIO12 PR0_PRU0_GPIO12_CFG_REG 0x5310 0190 0x0000 05F7	PR0_PRU0_GPIO12	0	IO	3.3 V	Off / Off / Off	Off / Off / Off	7	VDDSHV0	Yes	LVCMOS	PU/PD
		RMII2_TXD1	2	O								
		RGMII2_TD1	3	O								
		MII2_TXD1	4	O								
		EPWM28_B	5	O								
		GPMC0_A8	6	O								
		GPIO100	7	IO								
H17	PR0_PRU0_GPIO13 PR0_PRU0_GPIO13_CFG_REG 0x5310 0194 0x0000 05F7	PR0_PRU0_GPIO13	0	IO	3.3 V	Off / Off / Off	Off / Off / Off	7	VDDSHV0	Yes	LVCMOS	PU/PD
		RGMII2_TD2	3	O								
		MII2_TXD2	4	O								
		EPWM29_A	5	O								
		GPMC0_A9	6	O								
		GPIO101	7	IO								
		H16	PR0_PRU0_GPIO14 PR0_PRU0_GPIO14_CFG_REG 0x5310 0198 0x0000 05F7	PR0_PRU0_GPIO14								
RGMII2_TD3	3			O								
MII2_TXD3	4			O								
EPWM29_B	5			O								
GPMC0_A10	6			O								
GPIO102	7			IO								
L16	PR0_PRU0_GPIO15 PR0_PRU0_GPIO15_CFG_REG 0x5310 0188 0x0000 05F7			PR0_PRU0_GPIO15	0	IO	3.3 V	Off / Off / Off	Off / Off / Off	7	VDDSHV0	Yes
		RMII2_TX_EN	2	O								
		RGMII2_TX_CTL	3	O								
		MII2_TX_EN	4	O								
		EPWM27_B	5	O								
		GPMC0_A6	6	O								
		GPIO98	7	IO								
H18	PR0_PRU0_GPIO16 PR0_PRU0_GPIO16_CFG_REG 0x5310 0184 0x0000 05F7	PR0_PRU0_GPIO16	0	IO	3.3 V	Off / Off / Off	Off / Off / Off	7	VDDSHV0	Yes	LVCMOS	PU/PD
		RGMII2_TXC	3	O								
		MII2_TXCLK	4	I								
		EPWM27_A	5	O								
		GPMC0_A5	6	O								
		GPIO97	7	IO								
		F18	PR0_PRU1_GPIO0 PR0_PRU1_GPIO0_CFG_REG 0x5310 01B4 0x0000 05F7	PR0_PRU1_GPIO0								
FSITX2_DATA1	3			O								
TRC_DATA6	4			O								
GPMC0_A13	6			O								
GPIO109	7			IO								

表 6-1. Pin Attributes (ZCZ Package) (continued)

BALL NUMBER [1]	BALL NAME [2]/ IOMUX REGISTER [14]/ ADDRESS [15]/ DEFAULT VALUE [16]	SIGNAL NAME [3]	MUX MODE [4]	TYPE [5]	IO VOLTAGE [6]	BALL STATE DURING RESET RX/TX/PULL [7]	BALL STATE AFTER RESET RX/TX/PULL [8]	MUX MODE AFTER RESET [9]	POWER [10]	HYS [11]	BUFFER TYPE [12]	PULL TYPE [13]
G16	PR0_PRU1_GPIO1 PR0_PRU1_GPIO1_CFG_REG 0x5310 01B8 0x0000 05F7	PR0_PRU1_GPIO1	0	IO	3.3 V	Off / Off / Off	Off / Off / Off	7	VDDSHV0	Yes	LVCMOS	PU/PD
		FSIRX2_CLK	3	I								
		TRC_DATA7	4	O								
		GPMC0_A14	6	O								
		GPIO110	7	IO								
E17	PR0_PRU1_GPIO2 PR0_PRU1_GPIO2_CFG_REG 0x5310 01BC 0x0000 05F7	PR0_PRU1_GPIO2	0	IO	3.3 V	Off / Off / Off	Off / Off / Off	7	VDDSHV0	Yes	LVCMOS	PU/PD
		FSIRX2_DATA0	3	I								
		TRC_DATA8	4	O								
		GPMC0_A15	6	O								
		GPIO111	7	IO								
E18	PR0_PRU1_GPIO3 PR0_PRU1_GPIO3_CFG_REG 0x5310 01C0 0x0000 05F7	PR0_PRU1_GPIO3	0	IO	3.3 V	Off / Off / Off	Off / Off / Off	7	VDDSHV0	Yes	LVCMOS	PU/PD
		FSIRX2_DATA1	3	I								
		TRC_DATA9	4	O								
		GPMC0_A16	6	O								
		GPIO112	7	IO								
F16	PR0_PRU1_GPIO4 PR0_PRU1_GPIO4_CFG_REG 0x5310 01B0 0x0000 05F7	PR0_PRU1_GPIO4	0	IO	3.3 V	Off / Off / Off	Off / Off / Off	7	VDDSHV0	Yes	LVCMOS	PU/PD
		FSITX2_DATA0	3	O								
		TRC_DATA5	4	O								
		GPMC0_A12	6	O								
		GPIO108	7	IO								
F15	PR0_PRU1_GPIO5 PR0_PRU1_GPIO5_CFG_REG 0x5310 019C 0x0000 05F7	PR0_PRU1_GPIO5	0	IO	3.3 V	Off / Off / Off	Off / Off / Off	7	VDDSHV0	Yes	LVCMOS	PU/PD
		TRC_DATA0	4	O								
		EPWM30_A	5	O								
		GPMC0_OEn_REn	6	O								
		GPIO103	7	IO								
E16	PR0_PRU1_GPIO6 PR0_PRU1_GPIO6_CFG_REG 0x5310 01AC 0x0000 05F7	PR0_PRU1_GPIO6	0	IO	3.3 V	Off / Off / Off	Off / Off / Off	7	VDDSHV0	Yes	LVCMOS	PU/PD
		FSITX2_CLK	3	O								
		TRC_DATA4	4	O								
		GPMC0_A11	6	O								
		GPIO107	7	IO								
D18	PR0_PRU1_GPIO8 PR0_PRU1_GPIO8_CFG_REG 0x5310 01A8 0x0000 05F7	PR0_PRU1_GPIO8	0	IO	3.3 V	Off / Off / Off	Off / Off / Off	7	VDDSHV0	Yes	LVCMOS	PU/PD
		TRC_DATA3	4	O								
		EPWM31_B	5	O								
		GPMC0_WEn	6	O								
		GPIO106	7	IO								

表 6-1. Pin Attributes (ZCZ Package) (continued)

BALL NUMBER [1]	BALL NAME [2]/ IOMUX REGISTER [14]/ ADDRESS [15]/ DEFAULT VALUE [16]	SIGNAL NAME [3]	MUX MODE [4]	TYPE [5]	IO VOLTAGE [6]	BALL STATE DURING RESET RX/TX/PULL [7]	BALL STATE AFTER RESET RX/TX/PULL [8]	MUX MODE AFTER RESET [9]	POWER [10]	HYS [11]	BUFFER TYPE [12]	PULL TYPE [13]
C18	PR0_PRU1_GPIO9 PR0_PRU1_GPIO9_CFG_REG 0x5310 01A0 0x0000 05F7	PR0_PRU1_GPIO9	0	IO	3.3 V	Off / Off / Off	Off / Off / Off	7	VDDSHV0	Yes	LVCMOS	PU/PD
		PR0_UART0_RXD	3	I								
		TRC_DATA1	4	O								
		EPWM30_B	5	O								
		GPMC0_BE0n_CLE	6	O								
		GPIO104	7	IO								
D17	PR0_PRU1_GPIO10 PR0_PRU1_GPIO10_CFG_REG 0x5310 01A4 0x0000 05F7	PR0_PRU1_GPIO10	0	IO	3.3 V	Off / Off / Off	Off / Off / Off	7	VDDSHV0	Yes	LVCMOS	PU/PD
		PR0_UART0_TXD	3	O								
		TRC_DATA2	4	O								
		EPWM31_A	5	O								
		GPMC0_BE1n	6	O								
		GPIO105	7	IO								
B18	PR0_PRU1_GPIO11 PR0_PRU1_GPIO11_CFG_REG 0x5310 01CC 0x0000 05F7	PR0_PRU1_GPIO11	0	IO	3.3 V	Off / Off / Off	Off / Off / Off	7	VDDSHV0	Yes	LVCMOS	PU/PD
		FSITX3_DATA1	3	O								
		TRC_DATA12	4	O								
		GPMC0_A19	6	O								
		GPIO115	7	IO								
B17	PR0_PRU1_GPIO12 PR0_PRU1_GPIO12_CFG_REG 0x5310 01D0 0x0000 05F7	PR0_PRU1_GPIO12	0	IO	3.3 V	Off / Off / Off	Off / Off / Off	7	VDDSHV0	Yes	LVCMOS	PU/PD
		FSIRX3_CLK	3	I								
		TRC_DATA13	4	O								
		GPMC0_A20	6	O								
		GPIO116	7	IO								
D16	PR0_PRU1_GPIO13 PR0_PRU1_GPIO13_CFG_REG 0x5310 01D4 0x0000 05F7	PR0_PRU1_GPIO13	0	IO	3.3 V	Off / Off / Off	Off / Off / Off	7	VDDSHV0	Yes	LVCMOS	PU/PD
		FSIRX3_DATA0	3	I								
		TRC_DATA14	4	O								
		XBAROUT11	5	O								
		GPMC0_A21	6	O								
		GPIO117	7	IO								
C17	PR0_PRU1_GPIO14 PR0_PRU1_GPIO14_CFG_REG 0x5310 01D8 0x0000 05F7	PR0_PRU1_GPIO14	0	IO	3.3 V	Off / Off / Off	Off / Off / Off	7	VDDSHV0	Yes	LVCMOS	PU/PD
		FSIRX3_DATA1	3	I								
		TRC_DATA15	4	O								
		XBAROUT12	5	O								
		GPMC0_CSn0	6	O								
		GPIO118	7	IO								

表 6-1. Pin Attributes (ZCZ Package) (continued)

BALL NUMBER [1]	BALL NAME [2]/ IOMUX REGISTER [14]/ ADDRESS [15]/ DEFAULT VALUE [16]	SIGNAL NAME [3]	MUX MODE [4]	TYPE [5]	IO VOLTAGE [6]	BALL STATE DURING RESET RX/TX/PULL [7]	BALL STATE AFTER RESET RX/TX/PULL [8]	MUX MODE AFTER RESET [9]	POWER [10]	HYS [11]	BUFFER TYPE [12]	PULL TYPE [13]
A17	PR0_PRU1_GPIO15 PR0_PRU1_GPIO15_CFG_REG 0x5310 01C8 0x0000 05F7	PR0_PRU1_GPIO15	0	IO	3.3 V	Off / Off / Off	Off / Off / Off	7	VDDSHV0	Yes	LVCMOS	PU/PD
		FSITX3_DATA0	3	O								
		TRC_DATA11	4	O								
		GPMC0_A18	6	O								
		GPIO114	7	IO								
C16	PR0_PRU1_GPIO16 PR0_PRU1_GPIO16_CFG_REG 0x5310 01C4 0x0000 05F7	PR0_PRU1_GPIO16	0	IO	3.3 V	Off / Off / Off	Off / Off / Off	7	VDDSHV0	Yes	LVCMOS	PU/PD
		FSITX3_CLK	3	O								
		TRC_DATA10	4	O								
		GPMC0_A17	6	O								
		GPIO113	7	IO								
C15	PR0_PRU1_GPIO18 PR0_PRU1_GPIO18_CFG_REG 0x5310 01E0 0x0000 05F7	PR0_PRU1_GPIO18	0	IO	3.3 V	Off / Off / Off	Off / Off / Off	7	VDDSHV0	Yes	LVCMOS	PU/PD
		UART3_TXD	2	O								
		PR0_IEP0_EDIO_DATA_IN_OUT31	3	IO								
		TRC_CTL	4	O								
		XBAROUT14	5	O								
		GPMC0_WAIT1	6	I								
		GPIO120	7	IO								
		EQEP1_B	9	I								
D15	PR0_PRU1_GPIO19 PR0_PRU1_GPIO19_CFG_REG 0x5310 01DC 0x0000 05F7	PR0_PRU1_GPIO19	0	IO	3.3 V	Off / Off / Off	Off / Off / Off	7	VDDSHV0	Yes	LVCMOS	PU/PD
		UART3_RXD	2	I								
		PR0_IEP0_EDC_SYNC_OUT0	3	O								
		TRC_CLK	4	O								
		XBAROUT13	5	O								
		GPIO119	7	IO								
		EQEP1_A	9	I								
N2	QSPI0_CLK QSPI0_CLK_CFG_REG 0x5310 0008 0x0000 05F7	QSPI0_CLK	0	O	3.3 V	Off / Off / Off	Off / Off / Off	7	VDDSHV0	Yes	LVCMOS	PU/PD
		GPIO2	7	IO								
LB	QSPI0_CLKLB QSPI0_CLKLB_CFG_REG 0x5310 0244 0x5F0	QSPI0_CLKLB	0	IO	3.3 V	Off / Off / Off	Off / Off / Off	0	VDDSHV0	Yes	LVCMOS	PU/PD
P1	QSPI0_CSn0 QSPI0_CSn0_CFG_REG 0x5310 0000 0x0000 05F7	QSPI0_CSn0	0	O	3.3 V	Off / Off / Off	Off / Off / Off	7	VDDSHV0	Yes	LVCMOS	PU/PD
		GPIO0	7	IO								

表 6-1. Pin Attributes (ZCZ Package) (continued)

BALL NUMBER [1]	BALL NAME [2]/ IOMUX REGISTER [14]/ ADDRESS [15]/ DEFAULT VALUE [16]	SIGNAL NAME [3]	MUX MODE [4]	TYPE [5]	IO VOLTAGE [6]	BALL STATE DURING RESET RX/TX/PULL [7]	BALL STATE AFTER RESET RX/TX/PULL [8]	MUX MODE AFTER RESET [9]	POWER [10]	HYS [11]	BUFFER TYPE [12]	PULL TYPE [13]
R3	QSPI0_CSn1 QSPI0_CSn1_CFG_REG 0x5310 0004 0x0000 05F7	QSPI0_CSn1	0	O	3.3 V	Off / Off / Off	Off / Off / Off	7	VDDSHV0	Yes	LVCMOS	PU/PD
		XBAROUT0	5	O								
		GPIO1	7	IO								
N1	QSPI0_D0 QSPI0_D0_CFG_REG 0x5310 000C 0x0000 05D7	QSPI0_D0	0	IO	3.3 V	On / Off / Off	On / Off / Off	7	VDDSHV0	Yes	LVCMOS	PU/PD
		GPIO3	7	IO								
		SOP0	Bootstrap	0								
N4	QSPI0_D1 QSPI0_D1_CFG_REG 0x5310 0010 0x0000 05D7	QSPI0_D1	0	I	3.3 V	On / Off / Off	On / Off / Off	7	VDDSHV0	Yes	LVCMOS	PU/PD
		GPIO4	7	IO								
		SOP1	Bootstrap	0								
M4	QSPI0_D2 QSPI0_D2_CFG_REG 0x5310 0014 0x0000 05F7	QSPI0_D2	0	I	3.3 V	Off / Off / Off	Off / Off / Off	7	VDDSHV0	Yes	LVCMOS	PU/PD
		GPIO5	7	IO								
P3	QSPI0_D3 QSPI0_D3_CFG_REG 0x5310 0018 0x0000 05F7	QSPI0_D3	0	I	3.3 V	Off / Off / Off	Off / Off / Off	7	VDDSHV0	Yes	LVCMOS	PU/PD
		GPIO6	7	IO								
R17	RGMII1_RXC RGMII1_RXC_CFG_REG 0x5310 0074 0x0000 05F7	RGMII1_RXC	0	I	3.3 V	Off / Off / Off	Off / Off / Off	7	VDDSHV0	Yes	LVCMOS	PU/PD
		RMII1_REF_CLK	1	IO								
		MII1_RXCLK	2	I								
		FSITX0_CLK	6	O								
		GPIO29	7	IO								
		EQEP2_A	8	I								
R18	RGMII1_RX_CTL RGMII1_RX_CTL_CFG_REG 0x5310 0078 0x0000 05F7	RGMII1_RX_CTL	0	I	3.3 V	Off / Off / Off	Off / Off / Off	7	VDDSHV0	Yes	LVCMOS	PU/PD
		RMII1_RX_ER	1	I								
		MII1_RXDV	2	I								
		FSITX0_DATA0	6	O								
		GPIO30	7	IO								
		EQEP2_B	8	I								
N18	RGMII1_TXC RGMII1_TXC_CFG_REG 0x5310 008C 0x0000 05F7	RGMII1_TXC	0	O	3.3 V	Off / Off / Off	Off / Off / Off	7	VDDSHV0	Yes	LVCMOS	PU/PD
		MII1_TXCLK	2	I								
		FSITX1_CLK	6	O								
		GPIO35	7	IO								
		EQEP0_I	8	IO								

表 6-1. Pin Attributes (ZCZ Package) (continued)

BALL NUMBER [1]	BALL NAME [2]/ IOMUX REGISTER [14]/ ADDRESS [15]/ DEFAULT VALUE [16]	SIGNAL NAME [3]	MUX MODE [4]	TYPE [5]	IO VOLTAGE [6]	BALL STATE DURING RESET RX/TX/PULL [7]	BALL STATE AFTER RESET RX/TX/PULL [8]	MUX MODE AFTER RESET [9]	POWER [10]	HYS [11]	BUFFER TYPE [12]	PULL TYPE [13]
M18	RGMII1_TX_CTL RGMII1_TX_CTL_CFG_REG 0x5310 0090 0x0000 05F7	RGMII1_TX_CTL	0	O	3.3 V	Off / Off / Off	Off / Off / Off	7	VDDSHV0	Yes	LVCMOS	PU/PD
		RMII1_TX_EN	1	O								
		MII1_TX_EN	2	O								
		FSITX1_DATA0	6	O								
		GPIO36	7	IO								
		EQEP0_S	8	IO								
U17	RGMII1_RD0 RGMII1_RD0_CFG_REG 0x5310 007C 0x0000 05F7	RGMII1_RD0	0	I	3.3 V	Off / Off / Off	Off / Off / Off	7	VDDSHV0	Yes	LVCMOS	PU/PD
		RMII1_RXD0	1	I								
		MII1_RXD0	2	I								
		FSITX0_DATA1	6	O								
		GPIO31	7	IO								
		EQEP2_S	8	IO								
T17	RGMII1_RD1 RGMII1_RD1_CFG_REG 0x5310 0080 0x0000 05F7	RGMII1_RD1	0	I	3.3 V	Off / Off / Off	Off / Off / Off	7	VDDSHV0	Yes	LVCMOS	PU/PD
		RMII1_RXD1	1	I								
		MII1_RXD1	2	I								
		FSIRX0_CLK	6	I								
		GPIO32	7	IO								
		EQEP2_I	8	IO								
U18	RGMII1_RD2 RGMII1_RD2_CFG_REG 0x5310 0084 0x0000 05F7	RGMII1_RD2	0	I	3.3 V	Off / Off / Off	Off / Off / Off	7	VDDSHV0	Yes	LVCMOS	PU/PD
		MII1_RXD2	2	I								
		FSIRX0_DATA0	6	I								
		GPIO33	7	IO								
		EQEP0_A	8	I								
		T18	RGMII1_RD3 RGMII1_RD3_CFG_REG 0x5310 0088 0x0000 05F7	RGMII1_RD3								
MII1_RXD3	2			I								
FSIRX0_DATA1	6			I								
GPIO34	7			IO								
EQEP0_B	8			I								
P16	RGMII1_TD0 RGMII1_TD0_CFG_REG 0x5310 0094 0x0000 05F7			RGMII1_TD0	0	O	3.3 V	Off / Off / Off	Off / Off / Off	7	VDDSHV0	Yes
		RMII1_TXD0	1	O								
		MII1_TXD0	2	O								
		FSITX1_DATA1	6	O								
		GPIO37	7	IO								
		EQEP1_A	8	I								

表 6-1. Pin Attributes (ZCZ Package) (continued)

BALL NUMBER [1]	BALL NAME [2]/ IOMUX REGISTER [14]/ ADDRESS [15]/ DEFAULT VALUE [16]	SIGNAL NAME [3]	MUX MODE [4]	TYPE [5]	IO VOLTAGE [6]	BALL STATE DURING RESET RX/TX/PULL [7]	BALL STATE AFTER RESET RX/TX/PULL [8]	MUX MODE AFTER RESET [9]	POWER [10]	HYS [11]	BUFFER TYPE [12]	PULL TYPE [13]
P17	RGMII1_TD1 RGMII1_TD1_CFG_REG 0x5310 0098 0x0000 05F7	RGMII1_TD1	0	O	3.3 V	Off / Off / Off	Off / Off / Off	7	VDDSHV0	Yes	LVCMOS	PU/PD
		RMII1_TXD1	1	O								
		MII1_TXD1	2	O								
		FSIRX1_CLK	6	I								
		GPIO38	7	IO								
		EQEP1_B	8	I								
P18	RGMII1_TD2 RGMII1_TD2_CFG_REG 0x5310 009C 0x0000 05F7	RGMII1_TD2	0	O	3.3 V	Off / Off / Off	Off / Off / Off	7	VDDSHV0	Yes	LVCMOS	PU/PD
		RMII1_CRS_DV	1	I								
		MII1_TXD2	2	O								
		FSIRX1_DATA0	6	I								
		GPIO39	7	IO								
		EQEP1_S	8	IO								
N17	RGMII1_TD3 RGMII1_TD3_CFG_REG 0x5310 00A0 0x0000 05F7	RGMII1_TD3	0	O	3.3 V	Off / Off / Off	Off / Off / Off	7	VDDSHV0	Yes	LVCMOS	PU/PD
		MII1_TXD3	2	O								
		FSIRX1_DATA1	6	I								
		GPIO40	7	IO								
		EQEP1_I	8	IO								
J16	RSVD_J16	RSVD_J16		RSVD				Reserved		Reserved		
T4	RSVD_T4	RSVD_T4		RSVD								
U1	RSVD_U1	RSVD_U1		RSVD				Reserved		Reserved		
U3	RSVD_U3	RSVD_U3		RSVD				Reserved		Reserved		
V2	RSVD_V2	RSVD_V2		RSVD				Reserved		Reserved		
D4	SAFETY_ERRORn SAFETY_ERRORn_CFG_REG 0x5310 0230 0x410	SAFETY_ERRORn	0	IO	3.3 V	On / Off / Down	On / NA / Down	0	VDDSHV0	Yes	LVCMOS	PU/PD
B16	SDFM0_CLK0 SDFM0_CLK0_CFG_REG 0x5310 01E8 0x0000 05F7	CLKOUT1	0	O	3.3 V	Off / Off / Off	Off / Off / Off	7	VDDSHV0	Yes	LVCMOS	PU/PD
		GPIO122	7	IO								
		SDFM0_CLK0	8	I								
		EQEP1_S	9	IO								
A16	SDFM0_CLK1 SDFM0_CLK1_CFG_REG 0x5310 01F0 0x0000 05F7	PRO_PRU1_GPIO7	0	IO	3.3 V	Off / Off / Off	Off / Off / Off	7	VDDSHV0	Yes	LVCMOS	PU/PD
		CPTS0_TS_SYNC	1	O								
		UART5_RTSn	2	O								
		PRO_IEP0_EDC_SYNC_OUT1	3	O								
		I2C3_SDA	5	IO								
		GPIO124	7	IO								
		SDFM0_CLK1	8	I								

表 6-1. Pin Attributes (ZCZ Package) (continued)

BALL NUMBER [1]	BALL NAME [2]/ IOMUX REGISTER [14]/ ADDRESS [15]/ DEFAULT VALUE [16]	SIGNAL NAME [3]	MUX MODE [4]	TYPE [5]	IO VOLTAGE [6]	BALL STATE DURING RESET RX/TX/PULL [7]	BALL STATE AFTER RESET RX/TX/PULL [8]	MUX MODE AFTER RESET [9]	POWER [10]	HYS [11]	BUFFER TYPE [12]	PULL TYPE [13]
B15	SDFM0_CLK2 SDFM0_CLK2_CFG_REG 0x5310 01F8 0x0000 05F7	UART5_TXD	0	O	3.3 V	Off / Off / Off	Off / Off / Off	7	VDDSHV0	Yes	LVCMOS	PU/PD
		I2C3_SCL	5	IO								
		GPMC0_ADVn_ALE	6	O								
		GPIO126	7	IO								
		SDFM0_CLK2	8	I								
A15	SDFM0_CLK3 SDFM0_CLK3_CFG_REG 0x5310 0200 0x0000 05F7	MCAN3_TX	0	O	3.3 V	Off / Off / Off	Off / Off / Off	7	VDDSHV0	Yes	LVCMOS	PU/PD
		UART5_RXD	1	I								
		GPIO128	7	IO								
		SDFM0_CLK3	8	I								
D14	SDFM0_D0 SDFM0_D0_CFG_REG 0x5310 01EC 0x0000 05F7	PR0_ECAP0_APWM_OUT	0	O	3.3 V	Off / Off / Off	Off / Off / Off	7	VDDSHV0	Yes	LVCMOS	PU/PD
		GPIO123	7	IO								
		SDFM0_D0	8	I								
D13	SDFM0_D1 SDFM0_D1_CFG_REG 0x5310 01F4 0x0000 05F7	PR0_PRU1_GPIO17	0	IO	3.3 V	Off / Off / Off	Off / Off / Off	7	VDDSHV0	Yes	LVCMOS	PU/PD
		UART5_CTSn	2	I								
		PR0_IEP0_EDIO_DATA_IN_OUT30	3	IO								
		GPIO125	7	IO								
		SDFM0_D1	8	I								
C13	SDFM0_D2 SDFM0_D2_CFG_REG 0x5310 01FC 0x0000 05F7	UART5_RXD	0	I	3.3 V	Off / Off / Off	Off / Off / Off	7	VDDSHV0	Yes	LVCMOS	PU/PD
		GPIO127	7	IO								
		SDFM0_D2	8	I								
C14	SDFM0_D3 SDFM0_D3_CFG_REG 0x5310 0204 0x0000 05F7	MCAN3_RX	0	I	3.3 V	Off / Off / Off	Off / Off / Off	7	VDDSHV0	Yes	LVCMOS	PU/PD
		GPIO129	7	IO								
		SDFM0_D3	8	I								
A11	SPI0_CLK SPI0_CLK_CFG_REG 0x5310 0030 0x0000 05D7	SPI0_CLK	0	IO	3.3 V	On / Off / Off	On / Off / Off	7	VDDSHV0	Yes	LVCMOS	PU/PD
		UART3_TXD	1	O								
		LIN3_TXD	2	IO								
		FSITX0_CLK	6	O								
		GPIO12	7	IO								
		SOP2	Bootstrap	0								
A10	SPI1_CLK SPI1_CLK_CFG_REG 0x5310 0040 0x0000 05F7	SPI1_CLK	0	IO	3.3 V	Off / Off / Off	Off / Off / Off	7	VDDSHV0	Yes	LVCMOS	PU/PD
		UART4_RXD	1	I								
		LIN4_RXD	2	IO								
		XBAROUT2	5	O								
		FSIRX0_CLK	6	I								
		GPIO16	7	IO								

表 6-1. Pin Attributes (ZCZ Package) (continued)

BALL NUMBER [1]	BALL NAME [2]/ IOMUX REGISTER [14]/ ADDRESS [15]/ DEFAULT VALUE [16]	SIGNAL NAME [3]	MUX MODE [4]	TYPE [5]	IO VOLTAGE [6]	BALL STATE DURING RESET RX/TX/PULL [7]	BALL STATE AFTER RESET RX/TX/PULL [8]	MUX MODE AFTER RESET [9]	POWER [10]	HYS [11]	BUFFER TYPE [12]	PULL TYPE [13]
C11	SPI0_CS0 SPI0_CS0_CFG_REG 0x5310 002C 0x0000 05F7	SPI0_CS0	0	IO	3.3 V	Off / Off / Off	Off / Off / Off	7	VDDSHV0	Yes	LVCMOS	PU/PD
		UART3_RXD	1	I								
		LIN3_RXD	2	IO								
		GPIO11	7	IO								
C10	SPI0_D0 SPI0_D0_CFG_REG 0x5310 0034 0x0000 05D7	SPI0_D0	0	IO	3.3 V	On / Off / Off	On / Off / Off	7	VDDSHV0	Yes	LVCMOS	PU/PD
		FSITX0_DATA0	6	O								
		GPIO13	7	IO								
		SOP3	Bootstrap	0								
B11	SPI0_D1 SPI0_D1_CFG_REG 0x5310 0038 0x0000 05F7	SPI0_D1	0	IO	3.3 V	Off / Off / Off	Off / Off / Off	7	VDDSHV0	Yes	LVCMOS	PU/PD
		FSITX0_DATA1	6	O								
		GPIO14	7	IO								
C9	SPI1_CS0 SPI1_CS0_CFG_REG 0x5310 003C 0x0000 05F7	SPI1_CS0	0	IO	3.3 V	Off / Off / Off	Off / Off / Off	7	VDDSHV0	Yes	LVCMOS	PU/PD
		UART4_TXD	1	O								
		LIN4_TXD	2	IO								
		XBAROUT1	5	O								
		GPIO15	7	IO								
B10	SPI1_D0 SPI1_D0_CFG_REG 0x5310 0044 0x0000 05F7	SPI1_D0	0	IO	3.3 V	Off / Off / Off	Off / Off / Off	7	VDDSHV0	Yes	LVCMOS	PU/PD
		UART5_TXD	1	O								
		XBAROUT3	5	O								
		FSIRX0_DATA0	6	I								
		GPIO17	7	IO								
D9	SPI1_D1 SPI1_D1_CFG_REG 0x5310 0048 0x0000 05F7	SPI1_D1	0	IO	3.3 V	Off / Off / Off	Off / Off / Off	7	VDDSHV0	Yes	LVCMOS	PU/PD
		UART5_RXD	1	I								
		XBAROUT4	5	O								
		FSIRX0_DATA1	6	I								
		GPIO18	7	IO								
B3	TCK TCK_CFG_REG 0x5310 0240 0x210	TCK	0	I	3.3 V	On / NA / Up	On / NA / Up	0	VDDSHV0	Yes	HIGH HYST	
C5	TDI TDI_CFG_REG 0x5310 0234 0x6D0	TDI	0	I	3.3 V	On / Off / Up	On / Off / Up	0	VDDSHV0	Yes	LVCMOS	PU/PD
C4	TDO TDO_CFG_REG 0x5310 0238 0x630	TDO	0	O	3.3 V	Off / Off / Up	Off / NA / Up	0	VDDSHV0	Yes	LVCMOS	PU/PD

表 6-1. Pin Attributes (ZCZ Package) (continued)

BALL NUMBER [1]	BALL NAME [2]/ IOMUX REGISTER [14]/ ADDRESS [15]/ DEFAULT VALUE [16]	SIGNAL NAME [3]	MUX MODE [4]	TYPE [5]	IO VOLTAGE [6]	BALL STATE DURING RESET RX/TX/PULL [7]	BALL STATE AFTER RESET RX/TX/PULL [8]	MUX MODE AFTER RESET [9]	POWER [10]	HYS [11]	BUFFER TYPE [12]	PULL TYPE [13]
D5	TMS TMS_CFG_REG 0x5310 023C 0x610	TMS	0	IO	3.3 V	On / Off / Up	On / NA / Up	0	VDDSHV0	Yes	LVC MOS	PU/PD
B7	UART0_CTSn UART0_CTSn_CFG_REG 0x5310 0068 0x0000 05F7	UART0_CTSn	0	I	3.3 V	Off / Off / Off	Off / Off / Off	7	VDDSHV0	Yes	LVC MOS	PU/PD
		I2C2_SDA	1	IO								
		SPI3_D1	2	IO								
		MCAN3_RX	3	I								
		SPI0_CS1	4	IO								
		XBAROUT10	5	O								
		GPIO26	7	IO								
C7	UART0_RTSn UART0_RTSn_CFG_REG 0x5310 0064 0x0000 05F7	UART0_RTSn	0	O	3.3 V	Off / Off / Off	Off / Off / Off	7	VDDSHV0	Yes	LVC MOS	PU/PD
		I2C2_SCL	1	IO								
		SPI3_D0	2	IO								
		MCAN3_TX	3	O								
		XBAROUT9	5	O								
		GPIO25	7	IO								
		A7	UART0_RXD UART0_RXD_CFG_REG 0x5310 006C 0x0000 05F7	UART0_RXD								
LIN0_RXD	1			IO								
GPIO27	7			IO								
A6	UART0_TXD UART0_TXD_CFG_REG 0x5310 0070 0x0000 05F7	UART0_TXD	0	O	3.3 V	Off / Off / Off	Off / Off / Off	7	VDDSHV0	Yes	LVC MOS	PU/PD
		LIN0_TXD	1	IO								
		GPIO28	7	IO								
L3	UART1_RXD UART1_RXD_CFG_REG 0x5310 012C 0x0000 05F7	UART1_RXD	0	I	3.3 V	Off / Off / Off	Off / Off / Off	7	VDDSHV0	Yes	LVC MOS	PU/PD
		LIN1_RXD	1	IO								
		EPWM16_A	5	O								
		GPMC0_AD6	6	IO								
		GPIO75	7	IO								
M3	UART1_TXD UART1_TXD_CFG_REG 0x5310 0130 0x0000 05F7	UART1_TXD	0	O	3.3 V	Off / Off / Off	Off / Off / Off	7	VDDSHV0	Yes	LVC MOS	PU/PD
		LIN1_TXD	1	IO								
		EPWM16_B	5	O								
		GPMC0_AD7	6	IO								
		GPIO76	7	IO								

表 6-1. Pin Attributes (ZCZ Package) (continued)

BALL NUMBER [1]	BALL NAME [2]/ IOMUX REGISTER [14]/ ADDRESS [15]/ DEFAULT VALUE [16]	SIGNAL NAME [3]	MUX MODE [4]	TYPE [5]	IO VOLTAGE [6]	BALL STATE DURING RESET RX/TX/PULL [7]	BALL STATE AFTER RESET RX/TX/PULL [8]	MUX MODE AFTER RESET [9]	POWER [10]	HYS [11]	BUFFER TYPE [12]	PULL TYPE [13]
E11, E9, F11, F9, G13, G14, G5, G6, K13, K14, K5, K6, N13, N14, N5, N6, R9	VDD	VDD		PWR	1.2V							
R11, R8	VDDA18	VDDA18		PWR	1.8V							
R6	VDDA18_LDO	VDDA18_LDO		PWR	1.8V							
R4	VDDA18_OSC_PLL	VDDA18_OSC_PLL		PWR	1.8V							
P11, P7, P9	VDDA33	VDDA33		PWR	3.3V							
J15	VDDAR1	VDDAR1		PWR	1.2V							
D10	VDDAR2	VDDAR2		PWR	1.2V							
H3	VDDAR3	VDDAR3		PWR	1.2V							
D6, E15, L4, N15	VDDS18	VDDS18		PWR	1.8V							
T3	VDDS18_LDO	VDDS18_LDO		PWR	1.8V							
D12, D8, H15, H4, L15, P4, R15	VDDS33	VDDS33		PWR	3.3V							
N3	VPP	VPP		PWR	VPP							

表 6-1. Pin Attributes (ZCZ Package) (continued)

BALL NUMBER [1]	BALL NAME [2]/ IOMUX REGISTER [14]/ ADDRESS [15]/ DEFAULT VALUE [16]	SIGNAL NAME [3]	MUX MODE [4]	TYPE [5]	IO VOLTAGE [6]	BALL STATE DURING RESET RX/TX/PULL [7]	BALL STATE AFTER RESET RX/TX/PULL [8]	MUX MODE AFTER RESET [9]	POWER [10]	HYS [11]	BUFFER TYPE [12]	PULL TYPE [13]
A1, A18, E10, E12, E13, E14, E5, E6, E7, E8, F10, F12, F13, F14, F5, F6, F7, F8, G10, G11, G12, G7, G8, G9, H10, H11, H12, H13, H14, H5, H6, H7, H8, H9, J10, J11, J12, J13, J14, J5, J6, J7, J8, J9, K10, K11, K12, K7, K8, K9, L10, L11, L12, L13, L14, L5, L6, L7, L8, L9, M10, M11, M12, M13, M14, M5, M6, M7, M8, M9, N10, N11, N12, N7, N8, N9, P13, P14, P5, T2, V18	VSS	VSS		GND	VSS							
P10, P12, P6, P8, R13, R5, V1, V16	VSSA	VSSA		AGND	VSSA							
U2	VSYS_MON	VSYS_MON		PWR	1.2V				VDDA_CIO		AnalogCIO	
C3	WARMRSTn WARMRSTn_CFG_REG 0x5310 022C 0x510	WARMRSTn	0	IO	3.3 V	On / Off / Off	On / NA / Off	0	VDDSHV0		FS OD	
T1	XTAL_XI	XTAL_XI		I	1.8V			0	VDDS_OSC	Yes	HFOSC	
R1	XTAL_XO	XTAL_XO		O	1.8V			0	VDDS_OSC		HFOSC	

ADVANCE INFORMATION

6.3 Signal Descriptions

Many signals are available on multiple pins, according to the software configuration of the pin multiplexing options.

The following list describes the column headers:

1. **SIGNAL NAME:** The name of the signal passing through the pin.

备注

Signal names and descriptions provided in each Signal Descriptions table, represent the pin multiplexed signal function which is implemented at the pin and selected via PADCONFIG registers. Device subsystems may provide secondary multiplexing of signal functions, which are not described in these tables. For more information on secondary multiplexed signal functions, see the respective peripheral chapter of the device TRM.

2. **PIN TYPE:** Signal direction and type:
 - I = Input
 - O = Output
 - IO = Input, Output, or simultaneously Input and Output
 - IOD = Input, Output, or simultaneously Input and Output with open-drain output function
 - IOZ = Input, Output, or simultaneously Input and Output with three-state output function
 - OZ = Output with three-state output function
 - A = Analog
 - PWR = Power
 - GND = Ground
 - CAP = LDO Capacitor
3. **DESCRIPTION:** Description of the signal
4. **BALL:** Associated ball number

For more information on the I/O cell configurations, see the *Pad Configuration Registers* section within the *Device Configuration* chapter of the device TRM.

6.3.1 ADC

表 6-2. ADC0 Signal Descriptions

SIGNAL NAME [1]	PIN TYPE [2]	DESCRIPTION [3]	ZCZ PIN [4]
ADC0_AIN0	I	ADC Analog Input 0 (+IN0) CMPSSA0: inH (+IN)	V15
ADC0_AIN1	I	ADC Analog Input 1 (-IN0) CMPSSA0: inL (-IN)	U15
ADC0_AIN2	I	ADC Analog Input 2 (+IN1) CMPSSA1: inH (+IN)	T14
ADC0_AIN3	I	ADC Analog Input 3 (-IN1) CMPSSA1: inL (-IN)	U14
ADC0_AIN4	I	ADC Analog Input 4 (+IN2) CMPSSB0: inH/inL (+IN/-IN)	U13
ADC0_AIN5	I	ADC Analog Input 5 (-IN2) CMPSSB1: inH/inL (+IN/-IN)	R14

表 6-3. ADC1 Signal Descriptions

SIGNAL NAME [1]	PIN TYPE [2]	DESCRIPTION [3]	ZCZ PIN [4]
ADC1_AIN0	I	ADC Analog Input 0 (+IN0) CMPSSA2: inH (+IN)	T11
ADC1_AIN1	I	ADC Analog Input 1 (-IN0) CMPSSA2: inL (-IN)	U11
ADC1_AIN2	I	ADC Analog Input 2 (+IN1) CMPSSA3: inH (+IN)	T12
ADC1_AIN3	I	ADC Analog Input 3 (-IN1) CMPSSA3: inL (-IN)	V12
ADC1_AIN4	I	ADC Analog Input 4 (+IN2) CMPSSB2: inH/inL (+IN/-IN)	U12
ADC1_AIN5	I	ADC Analog Input 5 (-IN2) CMPSSB3: inH/inL (+IN/-IN)	R12

表 6-4. ADC2 Signal Descriptions

SIGNAL NAME [1]	PIN TYPE [2]	DESCRIPTION [3]	ZCZ PIN [4]
ADC2_AIN0	I	ADC Analog Input 0 (+IN0) CMPSSA4: inH (+IN)	R10
ADC2_AIN1	I	ADC Analog Input 1 (-IN0) CMPSSA4: inL (-IN)	T10
ADC2_AIN2	I	ADC Analog Input 2 (+IN1) CMPSSA5: inH (+IN)	U10
ADC2_AIN3	I	ADC Analog Input 3 (-IN1) CMPSSA5: inL (-IN)	T9
ADC2_AIN4	I	ADC Analog Input 4 (+IN2) CMPSSB4: inH/inL (+IN/-IN)	V9
ADC2_AIN5	I	ADC Analog Input 5 (-IN2) CMPSSB5: inH/inL (+IN/-IN)	T8

表 6-5. ADC3 Signal Descriptions

SIGNAL NAME [1]	PIN TYPE [2]	DESCRIPTION [3]	ZCZ PIN [4]
ADC3_AIN0	I	ADC Analog Input 0 (+IN0) CMPSSA6: inH (+IN)	U7
ADC3_AIN1	I	ADC Analog Input 1 (-IN0) CMPSSA6: inL (-IN)	U8

表 6-5. ADC3 Signal Descriptions (continued)

SIGNAL NAME [1]	PIN TYPE [2]	DESCRIPTION [3]	ZCZ PIN [4]
ADC3_AIN2	I	ADC Analog Input 2 (+IN1) CMPSSA7: inH (+IN)	T7
ADC3_AIN3	I	ADC Analog Input 3 (-IN1) CMPSSA7: inL (-IN)	R7
ADC3_AIN4	I	ADC Analog Input 4 (+IN2) CMPSSB6: inH/inL (+IN/-IN)	V8
ADC3_AIN5	I	ADC Analog Input 5 (-IN2) CMPSSB7: inH/inL (+IN/-IN)	U9

表 6-6. ADC4 Signal Descriptions

SIGNAL NAME [1]	PIN TYPE [2]	DESCRIPTION [3]	ZCZ PIN [4]
ADC4_AIN0	I	ADC Analog Input 0 (+IN0) CMPSSA8: inH (+IN)	U6
ADC4_AIN1	I	ADC Analog Input 1 (-IN0) CMPSSA8: inL (-IN)	V5
ADC4_AIN2	I	ADC Analog Input 2 (+IN1) CMPSSA9: inH (+IN)	V4
ADC4_AIN3	I	ADC Analog Input 3 (-IN1) CMPSSA9: inL (-IN)	U5
ADC4_AIN4	I	ADC Analog Input 4 (+IN2) CMPSSB8: inH/inL (+IN/-IN)	V3
ADC4_AIN5	I	ADC Analog Input 5 (-IN2) CMPSSB9: inH/inL (+IN/-IN)	U4

6.3.1.1 ADC-CMPSS Signal Connections

This table describes the connectivity between the ADC input signals/pins and the associated CMPSS signals.

Signal/Pin Name	ADC Input	CMPSS Input
ADC0_AIN0	ADC0:inp0 (+IN0)	CMPSSA0:inH (+IN)
ADC0_AIN1	ADC0:inm0 (-IN0)	CMPSSA0:inL (-IN)
ADC0_AIN2	ADC0:inp1 (+IN1)	CMPSSA1:inH (+IN)
ADC0_AIN3	ADC0:inm1 (-IN1)	CMPSSA1:inL (-IN)
ADC0_AIN4	ADC0:inp2 (+IN2)	CMPSSB0:inH/inL (+IN/-IN)
ADC0_AIN5	ADC0:inm2 (-IN2)	CMPSSB1:inH/inL (+IN/-IN)
ADC1_AIN0	ADC1:inp0 (+IN0)	CMPSSA2:inH (+IN)
ADC1_AIN1	ADC1:inm0 (-IN0)	CMPSSA2:inL (-IN)
ADC1_AIN2	ADC1:inp1 (+IN1)	CMPSSA3:inH (+IN)
ADC1_AIN3	ADC1:inm1 (-IN1)	CMPSSA3:inL (-IN)
ADC1_AIN4	ADC1:inp2 (+IN2)	CMPSSB2:inH/inL (+IN/-IN)
ADC1_AIN5	ADC1:inm2 (-IN2)	CMPSSB3:inH/inL (+IN/-IN)
ADC2_AIN0	ADC2:inp0 (+IN0)	CMPSSA4:inH (+IN)
ADC2_AIN1	ADC2:inm0 (-IN0)	CMPSSA4:inL (-IN)
ADC2_AIN2	ADC2:inp1 (+IN1)	CMPSSA5:inH (+IN)
ADC2_AIN3	ADC2:inm1 (-IN1)	CMPSSA5:inL (-IN)
ADC2_AIN4	ADC2:inp2 (+IN2)	CMPSSB4:inH/inL (+IN/-IN)
ADC2_AIN5	ADC2:inm2 (-IN2)	CMPSSB5:inH/inL (+IN/-IN)
ADC3_AIN0	ADC3:inp0 (+IN0)	CMPSSA6:inH (+IN)
ADC3_AIN1	ADC3:inm0 (-IN0)	CMPSSA6:inL (-IN)
ADC3_AIN2	ADC3:inp1 (+IN1)	CMPSSA7:inH (+IN)
ADC3_AIN3	ADC3:inm1 (-IN1)	CMPSSA7:inL (-IN)

This table describes the connectivity between the ADC input signals/pins and the associated CMPSS signals.

Signal/Pin Name	ADC Input	CMPSS Input
ADC3_AIN4	ADC3:inp2 (+IN2)	CMPSSB6:inH/inL (+IN/-IN)
ADC3_AIN5	ADC3:inm2 (-IN2)	CMPSSB7:inH/inL (+IN/-IN)
ADC4_AIN0	ADC4:inp0 (+IN0)	CMPSSA8:inH (+IN)
ADC4_AIN1	ADC4:inm0 (-IN0)	CMPSSA8:inL (-IN)
ADC4_AIN2	ADC4:inp1 (+IN1)	CMPSSA9:inH (+IN)
ADC4_AIN3	ADC4:inm1 (-IN1)	CMPSSA9:inL (-IN)
ADC4_AIN4	ADC4:inp2 (+IN2)	CMPSSB8:inH/inL (+IN/-IN)
ADC4_AIN5	ADC4:inm2 (-IN2)	CMPSSB9:inH/inL (+IN/-IN)
ADC_CAL0	ADC(0-4):inp3 (+IN3)	X
ADC_CAL1	ADC(0-4):inm3 (-IN3)	X

6.3.2 ADC VREF

表 6-7. ADC_VREF Signal Descriptions

SIGNAL NAME [1]	PIN TYPE [2]	DESCRIPTION [3]	ZCZ PIN [4]
ADC_CAL0	I	ADC Calibration Pin 0	U16
ADC_CAL1	I	ADC Calibration Pin 1	T15
ADC_VREFHI1	A	ADC Reference (Positive)	V10
ADC_VREFHISRC0	A	ADC Reference (Positive)	V14
ADC_VREFHISRC1	A	ADC Reference (Positive)	V6
ADC_VREFLO1	A	ADC Reference (Negative)	V11
ADC_VREFLOSRC0	A	ADC Reference (Negative)	V13
ADC_VREFLOSRC1	A	ADC Reference (Negative)	V7

6.3.3 CPSW

表 6-8. CPSW3G0 RGMII1 Signal Descriptions

SIGNAL NAME [1]	PIN TYPE [2]	DESCRIPTION [3]	ZCZ PIN [4]
RGMII1_RXC	I	RGMII Receive Clock	R17
RGMII1_RX_CTL	I	RGMII Receive Control	R18
RGMII1_TXC	O	RGMII Transmit Clock	N18
RGMII1_TX_CTL	O	RGMII Transmit Control	M18
RGMII1_RD0	I	RGMII Receive Data 0	U17
RGMII1_RD1	I	RGMII Receive Data 1	T17
RGMII1_RD2	I	RGMII Receive Data 2	U18
RGMII1_RD3	I	RGMII Receive Data 3	T18
RGMII1_TD0	O	RGMII Transmit Data 0	P16
RGMII1_TD1	O	RGMII Transmit Data 1	P17
RGMII1_TD2	O	RGMII Transmit Data 2	P18
RGMII1_TD3	O	RGMII Transmit Data 3	N17

表 6-9. CPSW3G0 RGMII2 Signal Descriptions

SIGNAL NAME [1]	PIN TYPE [2]	DESCRIPTION [3]	ZCZ PIN [4]
RGMII2_RXC	I	RGMII Receive Clock	K15
RGMII2_RX_CTL	I	RGMII Receive Control	K16
RGMII2_TXC	O	RGMII Transmit Clock	H18
RGMII2_TX_CTL	O	RGMII Transmit Control	L16

表 6-9. CPSW3G0 RGMII2 Signal Descriptions (continued)

SIGNAL NAME [1]	PIN TYPE [2]	DESCRIPTION [3]	ZCZ PIN [4]
RGMII2_RD0	I	RGMII Receive Data 0	K17
RGMII2_RD1	I	RGMII Receive Data 1	K18
RGMII2_RD2	I	RGMII Receive Data 2	J18
RGMII2_RD3	I	RGMII Receive Data 3	J17
RGMII2_TD0	O	RGMII Transmit Data 0	M16
RGMII2_TD1	O	RGMII Transmit Data 1	M15
RGMII2_TD2	O	RGMII Transmit Data 2	H17
RGMII2_TD3	O	RGMII Transmit Data 3	H16

表 6-10. CPSW3G0 RMII1 Signal Descriptions

SIGNAL NAME [1]	PIN TYPE [2]	DESCRIPTION [3]	ZCZ PIN [4]
RMII1_CRS_DV	I	RMII Carrier Sense / Data Valid	P18
RMII1_REF_CLK	IO	RMII Reference Clock	R17
RMII1_RX_ER	I	RMII Receive Data Error	R18
RMII1_TX_EN	O	RMII Transmit Enable	M18
RMII1_RXD0	I	RMII Receive Data 0	U17
RMII1_RXD1	I	RMII Receive Data 1	T17
RMII1_TXD0	O	RMII Transmit Data 0	P16
RMII1_TXD1	O	RMII Transmit Data 1	P17

表 6-11. CPSW3G0 RMII2 Signal Descriptions

SIGNAL NAME [1]	PIN TYPE [2]	DESCRIPTION [3]	ZCZ PIN [4]
RMII2_CRS_DV	I	RMII Carrier Sense / Data Valid	G18
RMII2_REF_CLK	IO	RMII Reference Clock	K15
RMII2_RX_ER	I	RMII Receive Data Error	G17
RMII2_TX_EN	O	RMII Transmit Enable	L16
RMII2_RXD0	I	RMII Receive Data 0	K17
RMII2_RXD1	I	RMII Receive Data 1	K18
RMII2_TXD0	O	RMII Transmit Data 0	M16
RMII2_TXD1	O	RMII Transmit Data 1	M15

表 6-12. CPSW3G0 MII1 Signal Descriptions

SIGNAL NAME [1]	PIN TYPE [2]	DESCRIPTION [3]	ZCZ PIN [4]
MII1_COL	I	MII Collision Detected	P15
MII1_CRS	I	MII Carrier Sense	R16
MII1_RXCLK	I	MII Receive Clock	R17
MII1_RXDV	I	MII Receive Data Valid	R18
MII1_RX_ER	I	MII Receive Data Error	T16
MII1_TXCLK	I	MII Transmit Clock	N18
MII1_TX_EN	O	MII Transmit Enable	M18
MII1_RXD0	I	MII Receive Data 0	U17
MII1_RXD1	I	MII Receive Data 1	T17
MII1_RXD2	I	MII Receive Data 2	U18
MII1_RXD3	I	MII Receive Data 3	T18
MII1_TXD0	O	MII Transmit Data 0	P16

表 6-12. CPSW3G0 MII1 Signal Descriptions (continued)

SIGNAL NAME [1]	PIN TYPE [2]	DESCRIPTION [3]	ZCZ PIN [4]
MII1_TXD1	O	MII Transmit Data 1	P17
MII1_TXD2	O	MII Transmit Data 2	P18
MII1_TXD3	O	MII Transmit Data 3	N17

表 6-13. CPSW3G0 MII2 Signal Descriptions

SIGNAL NAME [1]	PIN TYPE [2]	DESCRIPTION [3]	ZCZ PIN [4]
MII2_COL	I	MII Collision Detected	F17
MII2_CRS	I	MII Carrier Sense	G18
MII2_RXCLK	I	MII Receive Clock	K15
MII2_RXDV	I	MII Receive Data Valid	K16
MII2_RX_ER	I	MII Receive Error	G17
MII2_TXCLK	I	MII Transmit Clock	H18
MII2_TX_EN	O	MII Transmit Enable	L16
MII2_RXD0	I	MII Receive Data 0	K17
MII2_RXD1	I	MII Receive Data 1	K18
MII2_RXD2	I	MII Receive Data 2	J18
MII2_RXD3	I	MII Receive Data 3	J17
MII2_TXD0	O	MII Transmit Data 0	M16
MII2_TXD1	O	MII Transmit Data 1	M15
MII2_TXD2	O	MII Transmit Data 2	H17
MII2_TXD3	O	MII Transmit Data 3	H16

6.3.4 CPTS

表 6-14. CPTS0 Signal Descriptions

SIGNAL NAME [1]	PIN TYPE [2]	DESCRIPTION [3]	ZCZ PIN [4]
CPTS0_TS_SYNC	O	CPTS Time Stamp Counter Bit Output	A16

6.3.5 DAC

表 6-15. DAC Signal Descriptions

SIGNAL NAME [1]	PIN TYPE [2]	DESCRIPTION [3]	ZCZ PIN [4]
DAC_OUT	O	DAC Output	T5
DAC_VREF0	A	DAC Voltage Reference 0	T13
DAC_VREF1	A	DAC Voltage Reference 1	T6

6.3.6 Emulation and Debug

表 6-16. Trace Signal Descriptions

SIGNAL NAME [1]	PIN TYPE [2]	DESCRIPTION [3]	ZCZ PIN [4]
TRC_CLK	O	Trace Clock	D15
TRC_CTL	O	Trace Control	C15
TRC_DATA0	O	Trace Data 0	F15
TRC_DATA1	O	Trace Data 1	C18
TRC_DATA2	O	Trace Data 2	D17
TRC_DATA3	O	Trace Data 3	D18
TRC_DATA4	O	Trace Data 4	E16
TRC_DATA5	O	Trace Data 5	F16

表 6-16. Trace Signal Descriptions (continued)

SIGNAL NAME [1]	PIN TYPE [2]	DESCRIPTION [3]	ZCZ PIN [4]
TRC_DATA6	O	Trace Data 6	F18
TRC_DATA7	O	Trace Data 7	G16
TRC_DATA8	O	Trace Data 8	E17
TRC_DATA9	O	Trace Data 9	E18
TRC_DATA10	O	Trace Data 10	C16
TRC_DATA11	O	Trace Data 11	A17
TRC_DATA12	O	Trace Data 12	B18
TRC_DATA13	O	Trace Data 13	B17
TRC_DATA14	O	Trace Data 14	D16
TRC_DATA15	O	Trace Data 15	C17

表 6-17. JTAG Signal Descriptions

SIGNAL NAME [1]	PIN TYPE [2]	DESCRIPTION [3]	ZCZ PIN [4]
TCK	I	JTAG Test Clock Input	B3
TDI	I	JTAG Test Data Input	C5
TDO	O	JTAG Test Data Output	C4
TMS	IO	JTAG Test Mode Select Input	D5

6.3.7 EPWM

表 6-18. EPWM0 Signal Descriptions

SIGNAL NAME [1]	PIN TYPE [2]	DESCRIPTION [3]	ZCZ PIN [4]
EPWM0_A	O	EPWM Output A	B2
EPWM0_B	O	EPWM Output B	B1

表 6-19. EPWM1 Signal Descriptions

SIGNAL NAME [1]	PIN TYPE [2]	DESCRIPTION [3]	ZCZ PIN [4]
EPWM1_A	O	EPWM Output A	D3
EPWM1_B	O	EPWM Output B	D2

表 6-20. EPWM2 Signal Descriptions

SIGNAL NAME [1]	PIN TYPE [2]	DESCRIPTION [3]	ZCZ PIN [4]
EPWM2_A	O	EPWM Output A	C2
EPWM2_B	O	EPWM Output B	C1

表 6-21. EPWM3 Signal Descriptions

SIGNAL NAME [1]	PIN TYPE [2]	DESCRIPTION [3]	ZCZ PIN [4]
EPWM3_A	O	EPWM Output A	E2
EPWM3_B	O	EPWM Output B	E3

表 6-22. EPWM4 Signal Descriptions

SIGNAL NAME [1]	PIN TYPE [2]	DESCRIPTION [3]	ZCZ PIN [4]
EPWM4_A	O	EPWM Output A	D1
EPWM4_B	O	EPWM Output B	E4

表 6-23. EPWM5 Signal Descriptions

SIGNAL NAME [1]	PIN TYPE [2]	DESCRIPTION [3]	ZCZ PIN [4]
EPWM5_A	O	EPWM Output A	F2
EPWM5_B	O	EPWM Output B	G2

表 6-24. EPWM6 Signal Descriptions

SIGNAL NAME [1]	PIN TYPE [2]	DESCRIPTION [3]	ZCZ PIN [4]
EPWM6_A	O	EPWM Output A	E1
EPWM6_B	O	EPWM Output B	F3

表 6-25. EPWM7 Signal Descriptions

SIGNAL NAME [1]	PIN TYPE [2]	DESCRIPTION [3]	ZCZ PIN [4]
EPWM7_A	O	EPWM Output A	F4
EPWM7_B	O	EPWM Output B	F1

表 6-26. EPWM8 Signal Descriptions

SIGNAL NAME [1]	PIN TYPE [2]	DESCRIPTION [3]	ZCZ PIN [4]
EPWM8_A	O	EPWM Output A	G3
EPWM8_B	O	EPWM Output B	H2

表 6-27. EPWM9 Signal Descriptions

SIGNAL NAME [1]	PIN TYPE [2]	DESCRIPTION [3]	ZCZ PIN [4]
EPWM9_A	O	EPWM Output A	G1
EPWM9_B	O	EPWM Output B	J2

表 6-28. EPWM10 Signal Descriptions

SIGNAL NAME [1]	PIN TYPE [2]	DESCRIPTION [3]	ZCZ PIN [4]
EPWM10_A	O	EPWM Output A	G4
EPWM10_B	O	EPWM Output B	J3

表 6-29. EPWM11 Signal Descriptions

SIGNAL NAME [1]	PIN TYPE [2]	DESCRIPTION [3]	ZCZ PIN [4]
EPWM11_A	O	EPWM Output A	H1
EPWM11_B	O	EPWM Output B	J1

表 6-30. EPWM12 Signal Descriptions

SIGNAL NAME [1]	PIN TYPE [2]	DESCRIPTION [3]	ZCZ PIN [4]
EPWM12_A	O	EPWM Output A	K2
EPWM12_B	O	EPWM Output B	J4

表 6-31. EPWM13 Signal Descriptions

SIGNAL NAME [1]	PIN TYPE [2]	DESCRIPTION [3]	ZCZ PIN [4]
EPWM13_A	O	EPWM Output A	K4
EPWM13_B	O	EPWM Output B	K3

表 6-32. EPWM14 Signal Descriptions

SIGNAL NAME [1]	PIN TYPE [2]	DESCRIPTION [3]	ZCZ PIN [4]
EPWM14_A	O	EPWM Output A	V17
EPWM14_B	O	EPWM Output B	T16

表 6-33. EPWM15 Signal Descriptions

SIGNAL NAME [1]	PIN TYPE [2]	DESCRIPTION [3]	ZCZ PIN [4]
EPWM15_A	O	EPWM Output A	P15
EPWM15_B	O	EPWM Output B	R16

表 6-34. EPWM16 Signal Descriptions

SIGNAL NAME [1]	PIN TYPE [2]	DESCRIPTION [3]	ZCZ PIN [4]
EPWM16_A	O	EPWM Output A	L3
EPWM16_B	O	EPWM Output B	M3

表 6-35. EPWM17 Signal Descriptions

SIGNAL NAME [1]	PIN TYPE [2]	DESCRIPTION [3]	ZCZ PIN [4]
EPWM17_A	O	EPWM Output A	B6
EPWM17_B	O	EPWM Output B	A4

表 6-36. EPWM18 Signal Descriptions

SIGNAL NAME [1]	PIN TYPE [2]	DESCRIPTION [3]	ZCZ PIN [4]
EPWM18_A	O	EPWM Output A	B5
EPWM18_B	O	EPWM Output B	B4

表 6-37. EPWM19 Signal Descriptions

SIGNAL NAME [1]	PIN TYPE [2]	DESCRIPTION [3]	ZCZ PIN [4]
EPWM19_A	O	EPWM Output A	A3
EPWM19_B	O	EPWM Output B	A2

表 6-38. EPWM20 Signal Descriptions

SIGNAL NAME [1]	PIN TYPE [2]	DESCRIPTION [3]	ZCZ PIN [4]
EPWM20_A	O	EPWM Output A	C6
EPWM20_B	O	EPWM Output B	A5

表 6-39. EPWM21 Signal Descriptions

SIGNAL NAME [1]	PIN TYPE [2]	DESCRIPTION [3]	ZCZ PIN [4]
EPWM21_A	O	EPWM Output A	L17
EPWM21_B	O	EPWM Output B	L18

表 6-40. EPWM22 Signal Descriptions

SIGNAL NAME [1]	PIN TYPE [2]	DESCRIPTION [3]	ZCZ PIN [4]
EPWM22_A	O	EPWM Output A	G17
EPWM22_B	O	EPWM Output B	F17

表 6-41. EPWM23 Signal Descriptions

SIGNAL NAME [1]	PIN TYPE [2]	DESCRIPTION [3]	ZCZ PIN [4]
EPWM23_A	O	EPWM Output A	G18
EPWM23_B	O	EPWM Output B	G15

表 6-42. EPWM24 Signal Descriptions

SIGNAL NAME [1]	PIN TYPE [2]	DESCRIPTION [3]	ZCZ PIN [4]
EPWM24_A	O	EPWM Output A	K15
EPWM24_B	O	EPWM Output B	K16

表 6-43. EPWM25 Signal Descriptions

SIGNAL NAME [1]	PIN TYPE [2]	DESCRIPTION [3]	ZCZ PIN [4]
EPWM25_A	O	EPWM Output A	K17
EPWM25_B	O	EPWM Output B	K18

表 6-44. EPWM26 Signal Descriptions

SIGNAL NAME [1]	PIN TYPE [2]	DESCRIPTION [3]	ZCZ PIN [4]
EPWM26_A	O	EPWM Output A	J18
EPWM26_B	O	EPWM Output B	J17

表 6-45. EPWM27 Signal Descriptions

SIGNAL NAME [1]	PIN TYPE [2]	DESCRIPTION [3]	ZCZ PIN [4]
EPWM27_A	O	EPWM Output A	H18
EPWM27_B	O	EPWM Output B	L16

表 6-46. EPWM28 Signal Descriptions

SIGNAL NAME [1]	PIN TYPE [2]	DESCRIPTION [3]	ZCZ PIN [4]
EPWM28_A	O	EPWM Output A	M16
EPWM28_B	O	EPWM Output B	M15

表 6-47. EPWM29 Signal Descriptions

SIGNAL NAME [1]	PIN TYPE [2]	DESCRIPTION [3]	ZCZ PIN [4]
EPWM29_A	O	EPWM Output A	H17
EPWM29_B	O	EPWM Output B	H16

表 6-48. EPWM30 Signal Descriptions

SIGNAL NAME [1]	PIN TYPE [2]	DESCRIPTION [3]	ZCZ PIN [4]
EPWM30_A	O	EPWM Output A	F15
EPWM30_B	O	EPWM Output B	C18

表 6-49. EPWM31 Signal Descriptions

SIGNAL NAME [1]	PIN TYPE [2]	DESCRIPTION [3]	ZCZ PIN [4]
EPWM31_A	O	EPWM Output A	D17
EPWM31_B	O	EPWM Output B	D18

6.3.8 EQEP

表 6-50. EQEP0 Signal Descriptions

SIGNAL NAME [1]	PIN TYPE [2]	DESCRIPTION [3]	ZCZ PIN [4]
EQEP0_A	I	EQEP Quadrature Input A	B14, U18
EQEP0_B	I	EQEP Quadrature Input B	A14, T18
EQEP0_I	IO	EQEP Index	D11, N18
EQEP0_S	IO	EQEP Strobe	C12, M18

表 6-51. EQEP1 Signal Descriptions

SIGNAL NAME [1]	PIN TYPE [2]	DESCRIPTION [3]	ZCZ PIN [4]
EQEP1_A	I	EQEP Quadrature Input A	D15, P16
EQEP1_B	I	EQEP Quadrature Input B	C15, P17
EQEP1_I	IO	EQEP Index	N17, P2
EQEP1_S	IO	EQEP Strobe	B16, P18

表 6-52. EQEP2 Signal Descriptions

SIGNAL NAME [1]	PIN TYPE [2]	DESCRIPTION [3]	ZCZ PIN [4]
EQEP2_A	I	EQEP Quadrature Input A	B13, R17
EQEP2_B	I	EQEP Quadrature Input B	A13, R18
EQEP2_I	IO	EQEP Index	A12, T17
EQEP2_S	IO	EQEP Strobe	B12, U17

6.3.9 FSI

表 6-53. FSIRX0 Signal Descriptions

SIGNAL NAME [1]	PIN TYPE [2]	DESCRIPTION [3]	ZCZ PIN [4]
FSIRX0_CLK	I	FSI Clock	A10, T17
FSIRX0_DATA0	I	FSI Data 0	B10, U18
FSIRX0_DATA1	I	FSI Data 1	D9, T18

表 6-54. FSIRX1 Signal Descriptions

SIGNAL NAME [1]	PIN TYPE [2]	DESCRIPTION [3]	ZCZ PIN [4]
FSIRX1_CLK	I	FSI Clock	E1, P17
FSIRX1_DATA0	I	FSI Data 0	F3, P18
FSIRX1_DATA1	I	FSI Data 1	F4, N17

表 6-55. FSIRX2 Signal Descriptions

SIGNAL NAME [1]	PIN TYPE [2]	DESCRIPTION [3]	ZCZ PIN [4]
FSIRX2_CLK	I	FSI Clock	G16, J2
FSIRX2_DATA0	I	FSI Data 0	E17, G4
FSIRX2_DATA1	I	FSI Data 1	E18, J3

表 6-56. FSIRX3 Signal Descriptions

SIGNAL NAME [1]	PIN TYPE [2]	DESCRIPTION [3]	ZCZ PIN [4]
FSIRX3_CLK	I	FSI Clock	B17
FSIRX3_DATA0	I	FSI Data 0	D16
FSIRX3_DATA1	I	FSI Data 1	C17

表 6-57. FSITX0 Signal Descriptions

SIGNAL NAME [1]	PIN TYPE [2]	DESCRIPTION [3]	ZCZ PIN [4]
FSITX0_CLK	O	FSI Clock	A11, R17
FSITX0_DATA0	O	FSI Data 0	C10, R18
FSITX0_DATA1	O	FSI Data 1	B11, U17

表 6-58. FSITX1 Signal Descriptions

SIGNAL NAME [1]	PIN TYPE [2]	DESCRIPTION [3]	ZCZ PIN [4]
FSITX1_CLK	O	FSI Clock	E4, N18
FSITX1_DATA0	O	FSI Data 0	F2, M18
FSITX1_DATA1	O	FSI Data 1	G2, P16

表 6-59. FSITX2 Signal Descriptions

SIGNAL NAME [1]	PIN TYPE [2]	DESCRIPTION [3]	ZCZ PIN [4]
FSITX2_CLK	O	FSI Clock	E16, G3
FSITX2_DATA0	O	FSI Data 0	F16, H2
FSITX2_DATA1	O	FSI Data 1	F18, G1

表 6-60. FSITX3 Signal Descriptions

SIGNAL NAME [1]	PIN TYPE [2]	DESCRIPTION [3]	ZCZ PIN [4]
FSITX3_CLK	O	FSI Clock	C16
FSITX3_DATA0	O	FSI Data 0	A17
FSITX3_DATA1	O	FSI Data 1	B18

6.3.10 GPIO

表 6-61. GPIO Signal Descriptions

SIGNAL NAME [1]	PIN TYPE [2]	DESCRIPTION [3]	ZCZ PIN [4]
GPIO0	IO	General Purpose Input/Output	P1
GPIO1	IO	General Purpose Input/Output	R3
GPIO2	IO	General Purpose Input/Output	N2
GPIO3	IO	General Purpose Input/Output	N1
GPIO4	IO	General Purpose Input/Output	N4
GPIO5	IO	General Purpose Input/Output	M4
GPIO6	IO	General Purpose Input/Output	P3
GPIO7	IO	General Purpose Input/Output	M1
GPIO8	IO	General Purpose Input/Output	L1
GPIO9	IO	General Purpose Input/Output	L2
GPIO10	IO	General Purpose Input/Output	K1
GPIO11	IO	General Purpose Input/Output	C11
GPIO12	IO	General Purpose Input/Output	A11
GPIO13	IO	General Purpose Input/Output	C10
GPIO14	IO	General Purpose Input/Output	B11
GPIO15	IO	General Purpose Input/Output	C9
GPIO16	IO	General Purpose Input/Output	A10
GPIO17	IO	General Purpose Input/Output	B10
GPIO18	IO	General Purpose Input/Output	D9
GPIO19	IO	General Purpose Input/Output	A9

表 6-61. GPIO Signal Descriptions (continued)

SIGNAL NAME [1]	PIN TYPE [2]	DESCRIPTION [3]	ZCZ PIN [4]
GPIO100	IO	General Purpose Input/Output	M15
GPIO101	IO	General Purpose Input/Output	H17
GPIO102	IO	General Purpose Input/Output	H16
GPIO103	IO	General Purpose Input/Output	F15
GPIO104	IO	General Purpose Input/Output	C18
GPIO105	IO	General Purpose Input/Output	D17
GPIO106	IO	General Purpose Input/Output	D18
GPIO107	IO	General Purpose Input/Output	E16
GPIO108	IO	General Purpose Input/Output	F16
GPIO109	IO	General Purpose Input/Output	F18
GPIO110	IO	General Purpose Input/Output	G16
GPIO111	IO	General Purpose Input/Output	E17
GPIO112	IO	General Purpose Input/Output	E18
GPIO113	IO	General Purpose Input/Output	C16
GPIO114	IO	General Purpose Input/Output	A17
GPIO115	IO	General Purpose Input/Output	B18
GPIO116	IO	General Purpose Input/Output	B17
GPIO117	IO	General Purpose Input/Output	D16
GPIO118	IO	General Purpose Input/Output	C17
GPIO119	IO	General Purpose Input/Output	D15
GPIO120	IO	General Purpose Input/Output	C15
GPIO121	IO	General Purpose Input/Output	P2
GPIO122	IO	General Purpose Input/Output	B16
GPIO123	IO	General Purpose Input/Output	D14
GPIO124	IO	General Purpose Input/Output	A16
GPIO125	IO	General Purpose Input/Output	D13
GPIO126	IO	General Purpose Input/Output	B15
GPIO127	IO	General Purpose Input/Output	C13
GPIO128	IO	General Purpose Input/Output	A15
GPIO129	IO	General Purpose Input/Output	C14
GPIO130	IO	General Purpose Input/Output	B14
GPIO131	IO	General Purpose Input/Output	A14
GPIO132	IO	General Purpose Input/Output	C12
GPIO133	IO	General Purpose Input/Output	D11
GPIO134	IO	General Purpose Input/Output	B13
GPIO135	IO	General Purpose Input/Output	A13
GPIO136	IO	General Purpose Input/Output	B12
GPIO137	IO	General Purpose Input/Output	A12
GPIO138	IO	General Purpose Input/Output	M2
GPIO20	IO	General Purpose Input/Output	B9
GPIO21	IO	General Purpose Input/Output	B8
GPIO22	IO	General Purpose Input/Output	A8
GPIO23	IO	General Purpose Input/Output	D7
GPIO24	IO	General Purpose Input/Output	C8
GPIO25	IO	General Purpose Input/Output	C7

表 6-61. GPIO Signal Descriptions (continued)

SIGNAL NAME [1]	PIN TYPE [2]	DESCRIPTION [3]	ZCZ PIN [4]
GPIO26	IO	General Purpose Input/Output	B7
GPIO27	IO	General Purpose Input/Output	A7
GPIO28	IO	General Purpose Input/Output	A6
GPIO29	IO	General Purpose Input/Output	R17
GPIO30	IO	General Purpose Input/Output	R18
GPIO31	IO	General Purpose Input/Output	U17
GPIO32	IO	General Purpose Input/Output	T17
GPIO33	IO	General Purpose Input/Output	U18
GPIO34	IO	General Purpose Input/Output	T18
GPIO35	IO	General Purpose Input/Output	N18
GPIO36	IO	General Purpose Input/Output	M18
GPIO37	IO	General Purpose Input/Output	P16
GPIO38	IO	General Purpose Input/Output	P17
GPIO39	IO	General Purpose Input/Output	P18
GPIO40	IO	General Purpose Input/Output	N17
GPIO41	IO	General Purpose Input/Output	N16
GPIO42	IO	General Purpose Input/Output	M17
GPIO43	IO	General Purpose Input/Output	B2
GPIO44	IO	General Purpose Input/Output	B1
GPIO45	IO	General Purpose Input/Output	D3
GPIO46	IO	General Purpose Input/Output	D2
GPIO47	IO	General Purpose Input/Output	C2
GPIO48	IO	General Purpose Input/Output	C1
GPIO49	IO	General Purpose Input/Output	E2
GPIO50	IO	General Purpose Input/Output	E3
GPIO51	IO	General Purpose Input/Output	D1
GPIO52	IO	General Purpose Input/Output	E4
GPIO53	IO	General Purpose Input/Output	F2
GPIO54	IO	General Purpose Input/Output	G2
GPIO55	IO	General Purpose Input/Output	E1
GPIO56	IO	General Purpose Input/Output	F3
GPIO57	IO	General Purpose Input/Output	F4
GPIO58	IO	General Purpose Input/Output	F1
GPIO59	IO	General Purpose Input/Output	G3
GPIO60	IO	General Purpose Input/Output	H2
GPIO61	IO	General Purpose Input/Output	G1
GPIO62	IO	General Purpose Input/Output	J2
GPIO63	IO	General Purpose Input/Output	G4
GPIO64	IO	General Purpose Input/Output	J3
GPIO65	IO	General Purpose Input/Output	H1
GPIO66	IO	General Purpose Input/Output	J1
GPIO67	IO	General Purpose Input/Output	K2
GPIO68	IO	General Purpose Input/Output	J4
GPIO69	IO	General Purpose Input/Output	K4
GPIO70	IO	General Purpose Input/Output	K3

ADVANCE INFORMATION

表 6-61. GPIO Signal Descriptions (continued)

SIGNAL NAME [1]	PIN TYPE [2]	DESCRIPTION [3]	ZCZ PIN [4]
GPIO71	IO	General Purpose Input/Output	V17
GPIO72	IO	General Purpose Input/Output	T16
GPIO73	IO	General Purpose Input/Output	P15
GPIO74	IO	General Purpose Input/Output	R16
GPIO75	IO	General Purpose Input/Output	L3
GPIO76	IO	General Purpose Input/Output	M3
GPIO77	IO	General Purpose Input/Output	B6
GPIO78	IO	General Purpose Input/Output	A4
GPIO79	IO	General Purpose Input/Output	B5
GPIO80	IO	General Purpose Input/Output	B4
GPIO81	IO	General Purpose Input/Output	A3
GPIO82	IO	General Purpose Input/Output	A2
GPIO83	IO	General Purpose Input/Output	C6
GPIO84	IO	General Purpose Input/Output	A5
GPIO85	IO	General Purpose Input/Output	L17
GPIO86	IO	General Purpose Input/Output	L18
GPIO87	IO	General Purpose Input/Output	G17
GPIO88	IO	General Purpose Input/Output	F17
GPIO89	IO	General Purpose Input/Output	G18
GPIO90	IO	General Purpose Input/Output	G15
GPIO91	IO	General Purpose Input/Output	K15
GPIO92	IO	General Purpose Input/Output	K16
GPIO93	IO	General Purpose Input/Output	K17
GPIO94	IO	General Purpose Input/Output	K18
GPIO95	IO	General Purpose Input/Output	J18
GPIO96	IO	General Purpose Input/Output	J17
GPIO97	IO	General Purpose Input/Output	H18
GPIO98	IO	General Purpose Input/Output	L16
GPIO99	IO	General Purpose Input/Output	M16

6.3.11 GPMC

表 6-62. GPMC0 Signal Descriptions

SIGNAL NAME [1]	PIN TYPE [2]	DESCRIPTION [3]	ZCZ PIN [4]
GPMC0_ADVn_ALE	O	GPMC Address Valid (active low) or Address Latch Enable	B15
GPMC0_CLK (1)	IO	GPMC Clock	F17
GPMC0_CLKLB	IO	GPMC Clock Loopback	H1
GPMC0_DIR	O	GPMC Data Bus Signal Direction Control	G17
GPMC0_OEn_REn	O	GPMC Output Enable (active low) or Read Enable (active low)	F15, J1
GPMC0_WEn	O	GPMC Write Enable (active low)	D18, K2
GPMC0_WPn	O	GPMC Flash Write Protect (active low)	G15
GPMC0_A0	O	GPMC Address 0 Output. Only used to effectively address 8-bit data non-multiplexed memories	K16
GPMC0_A1	O	GPMC Address 1 Output in A/D non-multiplexed mode and Address 17 in A/D multiplexed mode	K17

表 6-62. GPMC0 Signal Descriptions (continued)

SIGNAL NAME [1]	PIN TYPE [2]	DESCRIPTION [3]	ZCZ PIN [4]
GPMC0_A2	O	GPMC Address 2 Output in A/D non-multiplexed mode and Address 18 in A/D multiplexed mode	K18
GPMC0_A3	O	GPMC Address 3 Output in A/D non-multiplexed mode and Address 19 in A/D multiplexed mode	J18
GPMC0_A4	O	GPMC Address 4 Output in A/D non-multiplexed mode and Address 20 in A/D multiplexed mode	J17
GPMC0_A5	O	GPMC Address 5 Output in A/D non-multiplexed mode and Address 21 in A/D multiplexed mode	H18
GPMC0_A6	O	GPMC Address 6 Output in A/D non-multiplexed mode and Address 22 in A/D multiplexed mode	L16
GPMC0_A7	O	GPMC Address 7 Output in A/D non-multiplexed mode and Address 23 in A/D multiplexed mode	M16
GPMC0_A8	O	GPMC Address 8 Output in A/D non-multiplexed mode and Address 24 in A/D multiplexed mode	M15
GPMC0_A9	O	GPMC Address 9 Output in A/D non-multiplexed mode and Address 25 in A/D multiplexed mode	H17
GPMC0_A10	O	GPMC Address 10 Output in A/D non-multiplexed mode and Address 26 in A/D multiplexed mode	H16
GPMC0_A11	O	GPMC Address 11 Output in A/D non-multiplexed mode and unused in A/D multiplexed mode	E16
GPMC0_A12	O	GPMC Address 12 Output in A/D non-multiplexed mode and unused in A/D multiplexed mode	F16
GPMC0_A13	O	GPMC Address 13 Output in A/D non-multiplexed mode and unused in A/D multiplexed mode	F18
GPMC0_A14	O	GPMC Address 14 Output in A/D non-multiplexed mode and unused in A/D multiplexed mode	G16
GPMC0_A15	O	GPMC Address 15 Output in A/D non-multiplexed mode and unused in A/D multiplexed mode	E17
GPMC0_A16	O	GPMC Address 16 Output in A/D non-multiplexed mode and unused in A/D multiplexed mode	E18
GPMC0_A17	O	GPMC Address 17 Output in A/D non-multiplexed mode and unused in A/D multiplexed mode	C16
GPMC0_A18	O	GPMC Address 18 Output in A/D non-multiplexed mode and unused in A/D multiplexed mode	A17
GPMC0_A19	O	GPMC Address 19 Output in A/D non-multiplexed mode and unused in A/D multiplexed mode	B18
GPMC0_A20	O	GPMC Address 20 Output in A/D non-multiplexed mode and unused in A/D multiplexed mode	B17
GPMC0_A21	O	GPMC Address 21 Output in A/D non-multiplexed mode and unused in A/D multiplexed mode	D16
GPMC0_AD0	IO	GPMC Data 0 Input/Output in A/D non-multiplexed mode and additionally Address 1 Output in A/D multiplexed mode	K4
GPMC0_AD1	IO	GPMC Data 1 Input/Output in A/D non-multiplexed mode and additionally Address 2 Output in A/D multiplexed mode	K3
GPMC0_AD2	IO	GPMC Data 2 Input/Output in A/D non-multiplexed mode and additionally Address 3 Output in A/D multiplexed mode	V17
GPMC0_AD3	IO	GPMC Data 3 Input/Output in A/D non-multiplexed mode and additionally Address 4 Output in A/D multiplexed mode	T16
GPMC0_AD4	IO	GPMC Data 4 Input/Output in A/D non-multiplexed mode and additionally Address 5 Output in A/D multiplexed mode	P15
GPMC0_AD5	IO	GPMC Data 5 Input/Output in A/D non-multiplexed mode and additionally Address 6 Output in A/D multiplexed mode	R16
GPMC0_AD6	IO	GPMC Data 6 Input/Output in A/D non-multiplexed mode and additionally Address 7 Output in A/D multiplexed mode	L3

ADVANCE INFORMATION

表 6-62. GPMC0 Signal Descriptions (continued)

SIGNAL NAME [1]	PIN TYPE [2]	DESCRIPTION [3]	ZCZ PIN [4]
GPMC0_AD7	IO	GPMC Data 7 Input/Output in A/D non-multiplexed mode and additionally Address 8 Output in A/D multiplexed mode	M3
GPMC0_AD8	IO	GPMC Data 8 Input/Output in A/D non-multiplexed mode and additionally Address 9 Output in A/D multiplexed mode	B6
GPMC0_AD9	IO	GPMC Data 9 Input/Output in A/D non-multiplexed mode and additionally Address 10 Output in A/D multiplexed mode	A4
GPMC0_AD10	IO	GPMC Data 10 Input/Output in A/D non-multiplexed mode and additionally Address 11 Output in A/D multiplexed mode	B5
GPMC0_AD11	IO	GPMC Data 11 Input/Output in A/D non-multiplexed mode and additionally Address 12 Output in A/D multiplexed mode	B4
GPMC0_AD12	IO	GPMC Data 12 Input/Output in A/D non-multiplexed mode and additionally Address 13 Output in A/D multiplexed mode	A3
GPMC0_AD13	IO	GPMC Data 13 Input/Output in A/D non-multiplexed mode and additionally Address 14 Output in A/D multiplexed mode	A2
GPMC0_AD14	IO	GPMC Data 14 Input/Output in A/D non-multiplexed mode and additionally Address 15 Output in A/D multiplexed mode	C6
GPMC0_AD15	IO	GPMC Data 15 Input/Output in A/D non-multiplexed mode and additionally Address 16 Output in A/D multiplexed mode	A5
GPMC0_BE0n_CLE	O	GPMC Lower-Byte Enable (active low) or Command Latch Enable	C18
GPMC0_BE1n	O	GPMC Upper-Byte Enable (active low)	D17
GPMC0_CSn0	O	GPMC Chip Select 0 (active low)	C17, J4
GPMC0_CSn1	O	GPMC Chip Select 1 (active low)	K15
GPMC0_CSn2	O	GPMC Chip Select 2 (active low)	L17
GPMC0_CSn3	O	GPMC Chip Select 3 (active low)	L18
GPMC0_WAIT0	I	GPMC External Indication of Wait	G18
GPMC0_WAIT1	I	GPMC External Indication of Wait	C15

(1) The RXACTIVE bit of the CTRLMMR_PADCONFIG32 register must be set to 0x1 and the TX_DIS bit of the CTRLMMR_PADCONFIG32 register must be reset to 0x0 when GPMC0 is operating in synchronous mode.

6.3.12 I2C

表 6-63. I2C0 Signal Descriptions

SIGNAL NAME [1]	PIN TYPE [2]	DESCRIPTION [3]	ZCZ PIN [4]
I2C0_SCL	IO	I2C Clock	A13
I2C0_SDA	IO	I2C Data	B13

表 6-64. I2C1 Signal Descriptions

SIGNAL NAME [1]	PIN TYPE [2]	DESCRIPTION [3]	ZCZ PIN [4]
I2C1_SCL	IO	I2C Clock	B5, D7
I2C1_SDA	IO	I2C Data	A3, C8

表 6-65. I2C2 Signal Descriptions

SIGNAL NAME [1]	PIN TYPE [2]	DESCRIPTION [3]	ZCZ PIN [4]
I2C2_SCL	IO	I2C Clock	C6, C7
I2C2_SDA	IO	I2C Data	A5, B7

表 6-66. I2C3 Signal Descriptions

SIGNAL NAME [1]	PIN TYPE [2]	DESCRIPTION [3]	ZCZ PIN [4]
I2C3_SCL	IO	I2C Clock	B15, H2

表 6-66. I2C3 Signal Descriptions (continued)

SIGNAL NAME [1]	PIN TYPE [2]	DESCRIPTION [3]	ZCZ PIN [4]
I2C3_SDA	IO	I2C Data	A16, G3

6.3.13 SPI (MCSPi)

表 6-67. LIN0 Signal Descriptions

SIGNAL NAME [1]	PIN TYPE [2]	DESCRIPTION [3]	ZCZ PIN [4]
LIN0_RXD	IO	LIN Receive Data	A7, B6
LIN0_TXD	IO	LIN Transmit Data	A4, A6

表 6-68. LIN1 Signal Descriptions

SIGNAL NAME [1]	PIN TYPE [2]	DESCRIPTION [3]	ZCZ PIN [4]
LIN1_RXD	IO	LIN Receive Data	A9, L3
LIN1_TXD	IO	LIN Transmit Data	B9, M3

表 6-69. LIN2 Signal Descriptions

SIGNAL NAME [1]	PIN TYPE [2]	DESCRIPTION [3]	ZCZ PIN [4]
LIN2_RXD	IO	LIN Receive Data	B8
LIN2_TXD	IO	LIN Transmit Data	A8

表 6-70. LIN3 Signal Descriptions

SIGNAL NAME [1]	PIN TYPE [2]	DESCRIPTION [3]	ZCZ PIN [4]
LIN3_RXD	IO	LIN Receive Data	C11
LIN3_TXD	IO	LIN Transmit Data	A11

表 6-71. LIN4 Signal Descriptions

SIGNAL NAME [1]	PIN TYPE [2]	DESCRIPTION [3]	ZCZ PIN [4]
LIN4_RXD	IO	LIN Receive Data	A10, D11
LIN4_TXD	IO	LIN Transmit Data	C12, C9

6.3.14 MCAN

表 6-72. MCAN0 Signal Descriptions

SIGNAL NAME [1]	PIN TYPE [2]	DESCRIPTION [3]	ZCZ PIN [4]
MCAN0_RX	I	MCAN Receive Data	M1
MCAN0_TX	O	MCAN Transmit Data	L1

表 6-73. MCAN1 Signal Descriptions

SIGNAL NAME [1]	PIN TYPE [2]	DESCRIPTION [3]	ZCZ PIN [4]
MCAN1_RX	I	MCAN Receive Data	L2
MCAN1_TX	O	MCAN Transmit Data	K1

表 6-74. MCAN2 Signal Descriptions

SIGNAL NAME [1]	PIN TYPE [2]	DESCRIPTION [3]	ZCZ PIN [4]
MCAN2_RX	I	MCAN Receive Data	A12
MCAN2_TX	O	MCAN Transmit Data	B12

表 6-75. MCAN3 Signal Descriptions

SIGNAL NAME [1]	PIN TYPE [2]	DESCRIPTION [3]	ZCZ PIN [4]
MCAN3_RX	I	MCAN Receive Data	B7, C14
MCAN3_TX	O	MCAN Transmit Data	A15, C7

6.3.15 SPI (MCSPI)

表 6-76. SPI0 Signal Descriptions

SIGNAL NAME [1]	PIN TYPE [2]	DESCRIPTION [3]	ZCZ PIN [4]
SPI0_CLK	IO	SPI Clock	A11
SPI0_CS0	IO	SPI Chip Select 0	C11
SPI0_CS1	IO	SPI Chip Select 1	B7
SPI0_D0	IO	SPI Data 0	C10
SPI0_D1	IO	SPI Data 1	B11

表 6-77. SPI1 Signal Descriptions

SIGNAL NAME [1]	PIN TYPE [2]	DESCRIPTION [3]	ZCZ PIN [4]
SPI1_CLK	IO	SPI Clock	A10
SPI1_CS0	IO	SPI Chip Select 0	C9
SPI1_D0	IO	SPI Data 0	B10
SPI1_D1	IO	SPI Data 1	D9

表 6-78. SPI2 Signal Descriptions

SIGNAL NAME [1]	PIN TYPE [2]	DESCRIPTION [3]	ZCZ PIN [4]
SPI2_CLK	IO	SPI Clock	B9
SPI2_CS0	IO	SPI Chip Select 0	A9
SPI2_D0	IO	SPI Data 0	B8
SPI2_D1	IO	SPI Data 1	A8

表 6-79. SPI3 Signal Descriptions

SIGNAL NAME [1]	PIN TYPE [2]	DESCRIPTION [3]	ZCZ PIN [4]
SPI3_CLK	IO	SPI Clock	C8
SPI3_CS0	IO	SPI Chip Select 0	D7
SPI3_D0	IO	SPI Data 0	C7
SPI3_D1	IO	SPI Data 1	B7

表 6-80. SPI4 Signal Descriptions

SIGNAL NAME [1]	PIN TYPE [2]	DESCRIPTION [3]	ZCZ PIN [4]
SPI4_CLK	IO	SPI Clock	B14, L1
SPI4_CS0	IO	SPI Chip Select 0	A14, M1
SPI4_CS1	IO	SPI Chip Select 1	K2
SPI4_D0	IO	SPI Data 0	C12, L2
SPI4_D1	IO	SPI Data 1	D11, K1

6.3.16 MDIO

表 6-81. MDIO0 Signal Descriptions

SIGNAL NAME [1]	PIN TYPE [2]	DESCRIPTION [3]	ZCZ PIN [4]
MDIO0_MDC	O	MDIO Clock	M17

表 6-81. MDIO0 Signal Descriptions (continued)

SIGNAL NAME [1]	PIN TYPE [2]	DESCRIPTION [3]	ZCZ PIN [4]
MDIO0_MDIO	IO	MDIO Data	N16

6.3.17 MMC

表 6-82. MMC0 Signal Descriptions

SIGNAL NAME [1]	PIN TYPE [2]	DESCRIPTION [3]	ZCZ PIN [4]
MMC0_CD	I	MMC/SD Card Detect	A5
MMC0_CLK	IO	MMC/SD Clock	B6
MMC0_CMD	IO	MMC/SD Command	A4
MMC0_WP	I	MMC/SD Write Protect	C6
MMC0_D0	IO	MMC/SD Data	B5
MMC0_D1	IO	MMC/SD Data	B4
MMC0_D2	IO	MMC/SD Data	A3
MMC0_D3	IO	MMC/SD Data	A2

6.3.18 Power Supply

表 6-83. Power Supply Signal Descriptions

SIGNAL NAME [1]	PIN TYPE [2]	DESCRIPTION [3]	ZCZ PIN [4]
VDD	PWR	1.2V Core supply	E11, E9, F11, F9, G13, G14, G5, G6, K13, K14, K5, K6, N13, N14, N5, N6, R9
VDDA18	PWR	1.8V Analog supply	R11, R8
VDDA18_LDO (1) (2)	PWR	1.8V Analog LDO Output	R6
VDDA18_OSC_PLL	PWR	1.8V OSC PLL supply	R4
VDDA33	PWR	3.3V Analog supply	P11, P7, P9
VDDAR1	PWR	1.2V SRAM Array supply	J15
VDDAR2	PWR	1.2V SRAM Array supply	D10
VDDAR3	PWR	1.2V SRAM Array supply	H3
VDDS18	PWR	1.8V IO supply	D6, E15, L4, N15
VDDS18_LDO (1) (3)	PWR	1.8V Digital LDO Output	T3
VDDS33	PWR	3.3V IO supply	D12, D8, H15, H4, L15, P4, R15
VPP	PWR	eFuse ROM programming supply	N3

表 6-83. Power Supply Signal Descriptions (continued)

SIGNAL NAME [1]	PIN TYPE [2]	DESCRIPTION [3]	ZCZ PIN [4]
VSS	GND	Ground	A1, A18, E10, E12, E13, E14, E5, E6, E7, E8, F10, F12, F13, F14, F5, F6, F7, F8, G10, G11, G12, G7, G8, G9, H10, H11, H12, H13, H14, H5, H6, H7, H8, H9, J10, J11, J12, J13, J14, J5, J6, J7, J8, J9, K10, K11, K12, K7, K8, K9, L10, L11, L12, L13, L14, L5, L6, L7, L8, L9, M10, M11, M12, M13, M14, M5, M6, M7, M8, M9, N10, N11, N12, N7, N8, N9, P13, P14, P5, T2, V18
VSSA	AGND	Analog Ground	P10, P12, P6, P8, R13, R5, V1, V16

- (1) This pin should be connected to 4.7- μ F output capacitor for proper LDO operation.
- (2) PCB should directly route VDDA18_LDO to all of the VDDA18 pins.
- (3) PCB should directly route VDDS18_LDO to all of the VDDS18 pins.

6.3.19 PRU_ICSSM

表 6-84. PRU_ICSSM Signal Descriptions

SIGNAL NAME [1]	PIN TYPE [2]	DESCRIPTION [3]	ZCZ PIN [4]
PR0_ECAP0_APWM_OUT	O	PRU_ICSSM Enhanced Capture (ECAP) Input or Auxiliary PWM (APWM) Output	D14
PR0_IEP0_EDC_SYNC_OUT0	O	PRU_ICSSM Industrial Ethernet Distributed Clock Sync Output	D15
PR0_IEP0_EDC_SYNC_OUT1	O	PRU_ICSSM Industrial Ethernet Distributed Clock Sync Output	A16
PR0_IEP0_EDIO_DATA_IN_OUT30	IO	PRU_ICSSM Industrial Ethernet Digital I/O Data Input/Output	D13
PR0_IEP0_EDIO_DATA_IN_OUT31	IO	PRU_ICSSM Industrial Ethernet Digital I/O Data Input/Output	C15
PR0_MDIO0_MDC	O	PRU_ICSSM MDIO Clock	L18
PR0_MDIO0_MDIO	IO	PRU_ICSSM MDIO Data	L17
PR0_PRU0_GPIO0	IO	PRU0 General Purpose Input/Output	K17
PR0_PRU0_GPIO1	IO	PRU0 General Purpose Input/Output	K18
PR0_PRU0_GPIO2	IO	PRU0 General Purpose Input/Output	J18
PR0_PRU0_GPIO3	IO	PRU0 General Purpose Input/Output	J17
PR0_PRU0_GPIO4	IO	PRU0 General Purpose Input/Output	K16
PR0_PRU0_GPIO5	IO	PRU0 General Purpose Input/Output	G17
PR0_PRU0_GPIO6	IO	PRU0 General Purpose Input/Output	K15
PR0_PRU0_GPIO8	IO	PRU0 General Purpose Input/Output	G15
PR0_PRU0_GPIO9	IO	PRU0 General Purpose Input/Output	F17
PR0_PRU0_GPIO10	IO	PRU0 General Purpose Input/Output	G18
PR0_PRU0_GPIO11	IO	PRU0 General Purpose Input/Output	M16
PR0_PRU0_GPIO12	IO	PRU0 General Purpose Input/Output	M15
PR0_PRU0_GPIO13	IO	PRU0 General Purpose Input/Output	H17

表 6-84. PRU_ICSSM Signal Descriptions (continued)

SIGNAL NAME [1]	PIN TYPE [2]	DESCRIPTION [3]	ZCZ PIN [4]
PR0_PRU0_GPIO14	IO	PRU0 General Purpose Input/Output	H16
PR0_PRU0_GPIO15	IO	PRU0 General Purpose Input/Output	L16
PR0_PRU0_GPIO16	IO	PRU0 General Purpose Input/Output	H18
PR0_PRU1_GPIO0	IO	PRU1 General Purpose Input/Output	F18
PR0_PRU1_GPIO1	IO	PRU1 General Purpose Input/Output	G16
PR0_PRU1_GPIO2	IO	PRU1 General Purpose Input/Output	E17
PR0_PRU1_GPIO3	IO	PRU1 General Purpose Input/Output	E18
PR0_PRU1_GPIO4	IO	PRU1 General Purpose Input/Output	F16
PR0_PRU1_GPIO5	IO	PRU1 General Purpose Input/Output	F15
PR0_PRU1_GPIO6	IO	PRU1 General Purpose Input/Output	E16
PR0_PRU1_GPIO7	IO	PRU1 General Purpose Input/Output	A16
PR0_PRU1_GPIO8	IO	PRU1 General Purpose Input/Output	D18
PR0_PRU1_GPIO9	IO	PRU1 General Purpose Input/Output	C18
PR0_PRU1_GPIO10	IO	PRU1 General Purpose Input/Output	D17
PR0_PRU1_GPIO11	IO	PRU1 General Purpose Input/Output	B18
PR0_PRU1_GPIO12	IO	PRU1 General Purpose Input/Output	B17
PR0_PRU1_GPIO13	IO	PRU1 General Purpose Input/Output	D16
PR0_PRU1_GPIO14	IO	PRU1 General Purpose Input/Output	C17
PR0_PRU1_GPIO15	IO	PRU1 General Purpose Input/Output	A17
PR0_PRU1_GPIO16	IO	PRU1 General Purpose Input/Output	C16
PR0_PRU1_GPIO17	IO	PRU1 General Purpose Input/Output	D13
PR0_PRU1_GPIO18	IO	PRU1 General Purpose Input/Output	C15
PR0_PRU1_GPIO19	IO	PRU1 General Purpose Input/Output	D15
PR0_UART0_CTSn	I	PRU_ICSSM UART Clear to Send (Active Low)	F17
PR0_UART0_RTSn	O	PRU_ICSSM UART Request to Send (Active Low)	G18
PR0_UART0_RXD	I	PRU_ICSSM UART Receive Data	C18
PR0_UART0_TXD	O	PRU_ICSSM UART Transmit Data	D17

ADVANCE INFORMATION

6.3.20 QSPI

表 6-85. QSPI0 Signal Descriptions

SIGNAL NAME [1]	PIN TYPE [2]	DESCRIPTION [3]	ZCZ PIN [4]
QSPI0_CLK	O	QSPI Clock	N2
QSPI0_CLKLB	IO	QSPI Clock Loopback	LB
QSPI0_CSn0	O	QSPI Chip Select 0	P1
QSPI0_CSn1	O	QSPI Chip Select 1	R3
QSPI0_D0	IO	QSPI Data bit 0	N1
QSPI0_D1	I	QSPI Data bit 1	N4
QSPI0_D2	I	QSPI Data bit 2	M4
QSPI0_D3	I	QSPI Data bit 3	P3

6.3.21 Reserved

表 6-86. Reserved Signal Descriptions

SIGNAL NAME [1]	PIN TYPE [2]	DESCRIPTION [3]	ZCZ PIN [4]
RSVD_J16	RSVD	Reserved (RSVD_J16). This pin must be connected to 1.2V supply (VDD).	J16

表 6-86. Reserved Signal Descriptions (continued)

SIGNAL NAME [1]	PIN TYPE [2]	DESCRIPTION [3]	ZCZ PIN [4]
RSVD_T4	RSVD	Reserved (RSVD_T4). This pin must be connected to ground (VSS).	T4
RSVD_U1	RSVD	Reserved (RSVD_U1). This pin must be connected to ground (VSS).	U1
RSVD_U3	RSVD	Reserved (RSVD_U3). This pin must be left unconnected.	U3
RSVD_V2	RSVD	Reserved (RSVD_V2). This pin must be left unconnected.	V2

6.3.22 SDFM

表 6-87. SDFM0 Signal Descriptions

SIGNAL NAME [1]	PIN TYPE [2]	DESCRIPTION [3]	ZCZ PIN [4]
SDFM0_CLK0	I	SDFM Clock 0 Input	B16
SDFM0_CLK1	I	SDFM Clock 1 Input	A16
SDFM0_CLK2	I	SDFM Clock 2 Input	B15
SDFM0_CLK3	I	SDFM Clock 3 Input	A15
SDFM0_D0	I	SDFM Data 0 Input	D14
SDFM0_D1	I	SDFM Data 1 Input	D13
SDFM0_D2	I	SDFM Data 2 Input	C13
SDFM0_D3	I	SDFM Data 3 Input	C14

表 6-88. SDFM1 Signal Descriptions

SIGNAL NAME [1]	PIN TYPE [2]	DESCRIPTION [3]	ZCZ PIN [4]
SDFM1_CLK0	I	SDFM Clock 0 Input	B14, B6
SDFM1_CLK1	I	SDFM Clock 1 Input	B5, C12
SDFM1_CLK2	I	SDFM Clock 2 Input	A3, B13
SDFM1_CLK3	I	SDFM Clock 3 Input	A13, C6
SDFM1_D0	I	SDFM Data 0 Input	A14, A4
SDFM1_D1	I	SDFM Data 1 Input	B4, D11
SDFM1_D2	I	SDFM Data 2 Input	A2, B12
SDFM1_D3	I	SDFM Data 3 Input	A12, A5

6.3.23 System and Miscellaneous

6.3.23.1 Boot Mode Configuration

表 6-89. Boot Mode Signal Descriptions

SIGNAL NAME [1]	PIN TYPE [2]	DESCRIPTION [3]	ZCZ PIN [4]
SOP0	0	Boot Mode bit 0	N1
SOP1	0	Boot Mode bit 1	N4
SOP2	0	Boot Mode bit 2	A11
SOP3	0	Boot Mode bit 3	C10

6.3.23.2 CLOCK

表 6-90. XTAL Signal Descriptions

SIGNAL NAME [1]	PIN TYPE [2]	DESCRIPTION [3]	ZCZ PIN [4]
XTAL_XI	I	External Crystal (XTAL) Input	T1
XTAL_XO	O	External Crystal (XTAL) Output	R1

表 6-91. Output Clock Signal Descriptions

SIGNAL NAME [1]	PIN TYPE [2]	DESCRIPTION [3]	ZCZ PIN [4]
CLKOUT0	O	Output Clock 0	M2
CLKOUT1	O	Output Clock 1	B16

6.3.23.3 SYSTEM

表 6-92. System Signal Descriptions

SIGNAL NAME [1]	PIN TYPE [2]	DESCRIPTION [3]	ZCZ PIN [4]
EXT_REFCLK0	I	External Reference Clock Input	P2
PORz	I	Device Power-On (PORz) cold reset	R2
SAFETY_ERRORn	IO	Safety Error Signal	D4
WARMRSTn	IO	Warm Reset Request (Input) / Warm Reset Status (Output)	C3

6.3.23.4 VMON

表 6-93. VMON Signal Descriptions

SIGNAL NAME [1]	PIN TYPE [2]	DESCRIPTION [3]	ZCZ PIN [4]
VSYS_MON	PWR	External Voltage Monitor (0.9V Setpoint)	U2

6.3.24 UART

表 6-94. UART0 Signal Descriptions

SIGNAL NAME [1]	PIN TYPE [2]	DESCRIPTION [3]	ZCZ PIN [4]
UART0_CTSn	I	UART Clear to Send (active low)	A5, B7
UART0_RTSn	O	UART Request to Send (active low)	C6, C7
UART0_RXD	I	UART Receive Data	A7, B6
UART0_TXD	O	UART Transmit Data	A4, A6

表 6-95. UART1 Signal Descriptions

SIGNAL NAME [1]	PIN TYPE [2]	DESCRIPTION [3]	ZCZ PIN [4]
UART1_CTSn	I	UART Clear to Send (active low)	G4
UART1_DCDn	I	UART Data Carrier Detect (Active Low)	J4
UART1_DSRn	I	UART Data Set Ready (Active Low)	V17
UART1_DTRn	O	UART Data Terminal Ready (Active Low)	K3
UART1_RIn	I	UART Ring Indicator	K4
UART1_RTSn	O	UART Request to Send (active low)	B12, J2
UART1_RXD	I	UART Receive Data	A9, L3
UART1_TXD	O	UART Transmit Data	B9, M3

表 6-96. UART2 Signal Descriptions

SIGNAL NAME [1]	PIN TYPE [2]	DESCRIPTION [3]	ZCZ PIN [4]
UART2_CTSn	I	UART Clear to Send (active low)	H1
UART2_RTSn	O	UART Request to Send (active low)	A12, J3
UART2_RXD	I	UART Receive Data	B5, B8
UART2_TXD	O	UART Transmit Data	A3, A8

表 6-97. UART3 Signal Descriptions

SIGNAL NAME [1]	PIN TYPE [2]	DESCRIPTION [3]	ZCZ PIN [4]
UART3_CTSn	I	UART Clear to Send (active low)	K2

表 6-97. UART3 Signal Descriptions (continued)

SIGNAL NAME [1]	PIN TYPE [2]	DESCRIPTION [3]	ZCZ PIN [4]
UART3_RTSn	O	UART Request to Send (active low)	A2, J1
UART3_RXD	I	UART Receive Data	C11, D15
UART3_TXD	O	UART Transmit Data	A11, C15

表 6-98. UART4 Signal Descriptions

SIGNAL NAME [1]	PIN TYPE [2]	DESCRIPTION [3]	ZCZ PIN [4]
UART4_CTSn	I	UART Clear to Send (active low)	A14
UART4_RTSn	O	UART Request to Send (active low)	B14
UART4_RXD	I	UART Receive Data	A10, D11, H2
UART4_TXD	O	UART Transmit Data	C12, C9, G3

表 6-99. UART5 Signal Descriptions

SIGNAL NAME [1]	PIN TYPE [2]	DESCRIPTION [3]	ZCZ PIN [4]
UART5_CTSn	I	UART Clear to Send (active low)	D13
UART5_RTSn	O	UART Request to Send (active low)	A16
UART5_RXD	I	UART Receive Data	A15, C13, D9, R16
UART5_TXD	O	UART Transmit Data	B10, B15, P15

6.3.25 XBAR

表 6-100. Output XBAR Signal Descriptions

SIGNAL NAME [1]	PIN TYPE [2]	DESCRIPTION [3]	ZCZ PIN [4]
XBAROUT0	O	OUTPUTXBAR Signal 0	R3
XBAROUT1	O	OUTPUTXBAR Signal 1	C9
XBAROUT2	O	OUTPUTXBAR Signal 2	A10
XBAROUT3	O	OUTPUTXBAR Signal 3	B10
XBAROUT4	O	OUTPUTXBAR Signal 4	D9
XBAROUT5	O	OUTPUTXBAR Signal 5	A9
XBAROUT6	O	OUTPUTXBAR Signal 6	B9
XBAROUT7	O	OUTPUTXBAR Signal 7	D7
XBAROUT8	O	OUTPUTXBAR Signal 8	C8
XBAROUT9	O	OUTPUTXBAR Signal 9	C7
XBAROUT10	O	OUTPUTXBAR Signal 10	B7
XBAROUT11	O	OUTPUTXBAR Signal 11	D16
XBAROUT12	O	OUTPUTXBAR Signal 12	C17
XBAROUT13	O	OUTPUTXBAR Signal 13	D15
XBAROUT14	O	OUTPUTXBAR Signal 14	C15
XBAROUT15	O	OUTPUTXBAR Signal 15	P2

6.4 Pin Connectivity Requirements

This section describes connectivity requirements for package balls that have specific connectivity requirements and package balls that may be unused.

备注

All power balls must be supplied with the voltages specified in the *Recommended Operating Conditions* section, unless otherwise specified in *Signal Descriptions*.

备注

For additional clarification, "leave unconnected" or "no connect" (NC) means **no** signal traces should be connected to these device ball numbers.

表 6-101. Connectivity Requirements

BALL NUMBER	BALL NAME	CONNECTION REQUIREMENTS
D4	SAFETY_ERRORn	Each of these balls must be connected to VSS through separate external pull resistors to ensure they are held to a valid logic low level if a PCB signal trace is connected and not actively driven by an attached device. The internal pull-down may be used to hold a valid logic low level if no PCB signal trace is connected to the ball.
B3 C5 D5	TCK TDI TMS	Each of these balls must be connected to the corresponding power supply ⁽¹⁾ through separate external pull resistors to ensure these balls are held to a valid logic high level if a PCB signal trace is connected and not actively driven by an attached device. The internal pull-up may be used to hold a valid logic high level if no PCB signal trace is connected to the ball.
A13 B13	I2C0_SCL I2C0_SDA	Each of these balls must be connected to the corresponding power supply ⁽¹⁾ through separate external pull resistors to ensure these balls are held to a valid logic high level.
K4 K3 V17 T16 P15 R16 L3 M3 B6 A4 B5 B4 A3 A2 C6 A5	GPMC0_AD0 GPMC0_AD1 GPMC0_AD2 GPMC0_AD3 GPMC0_AD4 GPMC0_AD5 GPMC0_AD6 GPMC0_AD7 GPMC0_AD8 GPMC0_AD9 GPMC0_AD10 GPMC0_AD11 GPMC0_AD12 GPMC0_AD13 GPMC0_AD14 GPMC0_AD15	Each of these balls must be connected to the corresponding power supply ⁽¹⁾ or ground (VSS) through separate external pull resistors to ensure these balls are held to a valid logic high or low level as appropriate to select the desired device boot mode.
TBD	TBD	If the entire ADC is not used, each of these balls must be connected directly to VSS.
TBD	TBD	Any unused ADC ball must be pulled to VSS through a resistor or connected directly to VSS when VDDA_ADC is connected to a power source.
J15 K14	VDDS_MMC0 VDDS_MMC0	If MMC0 is not used, each of these balls must be connected to any 1.8V power source that does not violate device power supply sequencing requirements.
B6 A4 B5 B4 A3 A2	MMC0_CLK MMC0_CMD MMC0_D0 MMC0_D1 MMC0_D2 MMC0_D3	If MMC0 is not used, each of these balls must be left unconnected.

表 6-101. Connectivity Requirements (continued)

BALL NUMBER	BALL NAME	CONNECTION REQUIREMENTS
TBD	TBD	If TBD is not used, each of these balls must be connected directly to ground (VSS).

(1) To determine which power supply is associated with any IO, see POWER column of the *Pin Attributes* table.

备注

Internal pull resistors are weak and may not source enough current to maintain a valid logic level for some operating conditions. This may be the case when connected to components with leakage to the opposite logic level, or when external noise sources couple to signal traces attached to balls which are only pulled to a valid logic level by the internal resistor. Therefore, external pull resistors may be required to hold a valid logic level on balls with external connections.

If balls are allowed to float between valid logic levels, the input buffer may enter a high-current state which could damage the IO cell.

7 Specifications

7.1 Absolute Maximum Ratings

over operating junction temperature range (unless otherwise noted)^{(1) (2)}

PARAMETER		MIN	MAX	UNIT
VDD	1.2V SOC core supply	- 0.5	1.5	V
VDDAR1	1.2V SRAM Array Supply 1	- 0.5	1.5	V
VDDAR2	1.2V SRAM Array Supply 2	- 0.5	1.5	V
VDDAR3	1.2V SRAM Array Supply 3	- 0.5	1.5	V
VDDS18	1.8V IO Bias Supply from Bias LDO routed through Board	- 0.5	2.1	V
VDDS33	3.3V IO Supply	- 0.5	4.0	V
VDDA18_OSC_PLL	1.8V Analog Supply for PLL. Routed from the 1.8V Analog LDO out through Board	- 0.5	2.1	V
VDDA33	Analog 3.3V Supply	- 0.5	4.0	V
VDDA18	1.8V Analog Supply. Routed from the 1.8V Analog LDO out through Board	- 0.5	2.1	V
IO Pin Steady State Voltage	3.3V LVCMOS IO Buffer	- 0.3	VDDS33 ⁽³⁾ + 0.3	V
	3.3V I2C Open-Drain IO Buffers	TBD	TBD	V
	XTAL Pad	TBD	TBD	V
Transient Overshoot and Undershoot	All Other IO Terminals	- 0.3	VDDS33 ⁽³⁾ + 0.2 × VDDS33 ⁽³⁾ for up to 20% of signal period	V
	XTAL Pad	TBD	TBD	V
Latch Up Performance Class II (150C)	Latch-up I-test Performance (Current-Pulse Injection on each IO pin)		±100	mA
	Latch-up Overvoltage Performance (Voltage Injection on each IO pin)		±100	mA
Output current	Digital output (per pin), I _{OUT}	- 20	20	mA
Storage temperature ⁽⁴⁾	T _{stg}	- 55	155	°C

- (1) Stresses beyond those listed under *Absolute Maximum Ratings* may cause permanent damage to the device. These are stress ratings only and functional operation of the device beyond the *Recommended Operating Conditions* is not implied. Exposure to absolute-maximum-rated conditions for extended periods may affect device reliability.
- (2) All voltage values are with respect to VSS, unless otherwise noted.
- (3) VDDS33 is the voltage on the corresponding power-supply pin(s) for the IC.
- (4) Long-term high-temperature storage or extended use at maximum temperature conditions may result in a reduction of overall device life. For additional information, see the [Semiconductor and IC Package Thermal Metrics Application Report](#).

7.2 Electrostatic Discharge (ESD) Ratings

over recommended operating conditions (unless otherwise noted)

			VALUE	UNIT	
V _(ESD)	Electrostatic Discharge	Human body model (HBM), per AEC-Q100-002 ⁽¹⁾	±2000	V	
		Charged device model (CDM), per AEC-Q100-011	All pins		±500
			Corner balls (A1, A18, V1, V18)		±750

- (1) AEC Q100-002 indicates that HBM stressing shall be in accordance with the ANSI/ESDA/JEDEC JS-001 specification

7.3 Power-On Hours (POH) Summary

over recommended operating conditions (unless otherwise noted)

PARAMETER	EXTENDED INDUSTRIAL	EXTENDED AUTOMOTIVE
Operating Junction Temperature (T _J)	- 40°C to 105°C	- 40°C to 150°C
POH @ Temp Profile	100K @ 97°C (100% @ 97°C) 70K @ 105°C (100% @ 105°C)	20K @ Automotive Temp Profile ⁽¹⁾

(1) See section *Automotive Temperature Profile*

7.3.1 Automotive Temperature Profile

T _J (°C)	HOURS	DAYS	YEARS	PERCENT OF TIME
- 40	1200	~50	~0.14	6%
75	4000	~167	~0.46	20%
95	13000	~541	~1.48	65%
130	1600	~67	~0.18	8%
150	200	~8.5	~0.023	1%
Total	20000	~833	~2.28	100%

7.4 Recommended Operating Conditions

over operating junction temperature range (unless otherwise noted)

PARAMETER	DESCRIPTION	MIN	NOM	MAX	UNIT	
VDD	1.2V SOC Core Supply	1.140	1.200	1.260	V	
VDDAR1, VDDAR2, VDDAR3	SRAM Array Supplies	1.140	1.200	1.260	V	
VDDS18	1.8V IO Bias Supply from Bias LDO routed through board	1.710	1.800	1.890	V	
VDDS33	3.3V IO Supply	3.135	3.300	3.465	V	
VDDA18_OSC_PLL	1.8V Analog supply for PLL. Routed from the Analog LDO out through board	1.710	1.800	1.890	V	
VDDA33	Analog 3.3V Supply	3.135	3.300	3.465	V	
VDDA18	1.8V Analog supply. Routed from 1.8V Analog LDO out through Board	1.710	1.800	1.890	V	
T _A	Free-air temperature	Extended Automotive		- 40	125	°C
T _J	Operating junction temperature range	Extended Industrial		- 40	105	°C
		Extended Automotive		- 40	150	°C

7.5 Operating Performance Points

This section describes the operating conditions of the device. This section also contains the description of each Operating Performance Point (OPP) for processor clocks, device core clocks, and available memory.

DEVICE	GRADE	RAM (MB)	R5FSS (MHz)	HSM (MHz)	ICSS (MHz)	INFRA (MHz) ⁽¹⁾
AM263x	M	0.5	400	200	200	200
AM263x	N	1	400	200	200	200
AM263x	O	2	400	200	200	200
AM263x	P	2	200	200	200	200

(1) Infrastructure includes all other modules and IP integrated in the device (such as CBASS/ Interconnect and other SoC level peripherals) unless otherwise noted in the table.

7.6 Power Consumption Summary

over recommended operating conditions (unless otherwise noted)

SUPPLY NAME	PARAMETER	MAX	UNIT
VDD + VDDARn	Maximum Current Rating for Core Domain	2.5	A
VDDS33	Maximum Current Rating for IO supply	200	mA
VDDA33	Maximum Current Rating for 3.3-V Analog supply	TBD	mA

7.7 Electrical Characteristics

备注

The interfaces or signals described in 节 7.7.1 *Digital and Analog IO Electrical Characteristics* through 节 7.7.6 *PMM* correspond to the interfaces or signals available in multiplexing mode 0 (Primary Function).

All interfaces or signals multiplexed on the balls described in these tables have the same DC electrical characteristics, unless multiplexing involves a PHY and GPIO combination, in which case different DC electrical characteristics are specified for the different multiplexing modes (Functions).

7.7.1 Digital and Analog IO Electrical Characteristics

over recommended operating conditions (unless otherwise noted)

PARAMETER		MIN	TYP	MAX	UNIT
TCK IO					
V _{IH}	High-Level Input Voltage	2.15			V
V _{IL}	Low-Level Input Voltage			0.55	V
V _{HYS}	Hysteresis Voltage at an Input	0.4			V
I _L	Input Leakage Current, Receiver Disabled, Pullup or Pulldown Inhibited	TBD	8.9	17.2	μA
	Input Leakage Current, Receiver Disabled, Pullup Enabled		106.9	128.2	μA
	Input Leakage Current, Receiver Disabled, Pulldown Enabled		100.3	130.3	μA
PORz IO					
V _{IH}	High-Level Input Voltage	1.35			V
V _{IL}	Low-Level Input Voltage			0.5	V
V _{HYS}	Hysteresis Voltage at an Input	0.070			V
I _L	Input Leakage Current	-2		2	μA
I2C OD IOs					
V _{IH}	High-Level Input Voltage	2			V
V _{IL}	Low-Level Input Voltage			0.8	V
V _{HYS}	Hysteresis Voltage at an Input	0.165			V
I _L	Input Leakage Current, Receiver Disabled, Pullup or Pulldown Inhibited	-18		18	μA
V _{OL}	Low Level Output Voltage, Driver Enabled : I _{OL} = 3mA			0.1 × VDDS33 ⁽¹⁾	V
All Other LVCMOS					
V _{IH}	High- Level Input Voltage	2			V
V _{IL}	Low-Level Input Voltage			0.8	V
V _{HYS}	Hysteresis Voltage at an Input	0.265			V
V _{OL}	Low Level Output Voltage, Driver Enabled : I _{OL} = 6mA			0.1 × VDDS33 ⁽¹⁾	V

over recommended operating conditions (unless otherwise noted)

PARAMETER		MIN	TYP	MAX	UNIT
V _{OH}	High Level Output Voltage, Driver Enabled : I _{OH} = 6mA	0.9 × V _{DDS33} ⁽¹⁾			V
I _L	Input Leakage Current, Receiver Disabled, Pullup or Pulldown Inhibited	-18		18	μ A
	Input Leakage Current, Receiver Disabled, Pullup Enabled	-243	-100	-19	μ A
	Input Leakage Current, Receiver Disabled, Pulldown Enabled	51	100	210	μ A
Warm Reset IO					
V _{IH}	High-Level Input Voltage	2			V
V _{IL}	Low-Level Input Voltage	0.8			V
V _{HYS}	Hysteresis Voltage at an Input	0.347			V
V _{OL}	Low Level Output Voltage, Driver Enabled : I _{OL} = 6mA	0.1 × V _{DDS33} ⁽¹⁾			V
I _L	Input Leakage Current, Receiver Disabled, Pulldown Inhibited	-57			μ A

(1) V_{DDS33} is the voltage on the corresponding power-supply pin(s) on the IC.

7.7.2 ADC

over operating junction temperature range (unless otherwise noted)

PARAMETER	TEST CONDITIONS	MIN	TYP	MAX	UNIT
V _{REFHI}		1.71	1.8	1.89	V
Input Conversion Range (Vin+, Vin-)	Must be < V _{DDA33}	0	33/18 × V _{REFHI}		V
Power-up time				500	μs
Gain error		- 5	±3	5	LSBs
Offset error		- 4	±2	4	LSBs
Channel-to-channel gain error			±4		LSBs
Channel-to-channel offset error			±2		LSBs
ADC-to-ADC gain error	Same reference group		±4		LSBs
ADC-to-ADC offset error	Same reference group		±2		LSBs
DNL	Controlled environment to minimize input noise	- 1	±0.5	1	LSBs
INL	Controlled environment to minimize input noise	- 2	±1.0	2	LSBs
SNR	Controlled environment to minimize input noise		68		dB
ENOB (Synchronous Operation)			11		bits
ENOB (Asynchronous Operation)			9.7		bits
ADC-to-ADC isolation	Synchronous operation	- 10		10	LSBs
V _{REFHI} input current			300		μA
Conversion time				250	ns
Input Resistance					
Input Capacitance					
Input Leakage				5	uA
Power supply (V _{DDA33})		3.13	3.3	3.46	V
Power supply (V _{DDA18})		1.71	1.8	1.89	V
Power Consumption (V _{DDA33})			200		μA
Power Consumption (V _{DDA18})			500		μA
Failsafe Input current injection	Other COMPs in same cluster not connected to this input should not make any error			10	mA

7.7.3 CMPSSA

SUBGROUP	PARAMETER	TEST CONDITIONS	MIN	TYP	MAX	UNIT
Comparator	Power-up time				10	μs
	Comparator input range		0.1		Minimum of 2 × DAC_VREF or VDDA33 ⁽¹⁾ - 50mV	
	Input referred offset error		- 20		20	mV
	Hysteresis		0		48	LSB
	Propagation delay			21		50 ns
DAC	DAC_VREF reference voltage		1.71	1.8	1.89	V
	DAC output range		0.1		Minimum of 33/18 × DAC_VREF or VDDA33 ⁽¹⁾ - 50mV	V
	Static offset error		- 45		45	mV
	Static gain error		- 2		2	% of FSR
	Static DNL		> - 1		4	LSB
	Static INL		- 16		16	LSB
	Settling time				1	μs
	Resolution			12		bits
	DAC output disturbance (comparator trip kickback)		- 100		100	LSB
	DAC output disturbance (comparator trip kickback)			200		ns
	DAC_VREF loading			6		kΩ
Common	Input Leakage			1		μA
	Power supply (VDDA33)		3.13	3.3	3.46	V
	Power supply (VDDA18)		1.71	1.8	1.89	V
	Power Consumption (VDDA33)			200		μA
	Power Consumption (VDDA18)			600		μA
	Failsafe Input current injection					10 mA

(1) VDDA33 is the voltage on the corresponding power-supply pin(s) on the IC.

7.7.4 CMPSSB

SUBGROUP	PARAMETER	TEST CONDITIONS	MIN	TYP	MAX	UNIT
Comparator	Power-up time				10	μs
	Comparator input range		0		1.8 × DAC_VREF	
	Input referred offset error		- 20		20	mV
	Hysteresis		12		48	LSB
	Step response time			21		50 ns

SUBGROUP	PARAMETER	TEST CONDITIONS	MIN	TYP	MAX	UNIT
DAC	DAC_VREF reference voltage		1.71	1.8	1.89	V
	DAC output range		0		DAC_VREF	V
	Static offset error		- 45		45	mV
	Static gain error		- 2		2	% of FSR
	Static DNL		> - 1		4	LSB
	Static INL		- 16		16	LSB
	Settling time				2	μs
	Resolution			12		bits
	DAC output disturbance (comparator trip kickback)		- 100		100	LSB
	DAC output disturbance (comparator trip kickback)			200		ns
	DAC_VREF loading			6		kΩ
Common	Input leakage			1		μA
	Power supply (VDDA33)		3.13	3.3	3.46	V
	Power supply (VDDA18)		1.71	1.8	1.89	V
	Power consumption (VDDA33)			200		μA
	Power consumption (VDDA18)			500		μA
	Failsafe input current injection				10	mA

7.7.5 DAC

over operating junction temperature range (unless otherwise noted)

PARAMETER	TEST CONDITIONS	MIN	TYP	MAX	UNIT
Power-up time				10	μs
DAC_VREF		1.71	1.8	1.89	V
Voltage output range		0.3	VDDA33 ⁽¹⁾ - 0.3		V
Trimmed offset error	Offset is checked at Midpoint (code 2048)	- 10		10	mV
Gain error	DAC_VREF = 1.8V	- 2.5		2.5	% of FSR
DNL	Endpoint corrected	- 1		1	LSB
INL	Endpoint corrected	- 20		20	LSB
Settling time	Settling to 2 LSBs (~1.6mV) after 0.3V-to-3V transition		2		μs
Resolution			12		bits
Capacitive load	Output drive capability			100	pF
Resistive load	Output drive capability	5			kΩ
DAC_VREF loading	DAC_VREF		64		kΩ
Output noise (100 Hz- 100 KHz)	Integrated noise from 100 Hz to 100 kHz		1		mVrms
SNR @ 1KHz	2MHz DACVALA update rate, 200kHz output filter		60		dB
Power supply (VDDA33)		3.13	3.3	3.46	V
Power supply (VDDA18)		1.71	1.8	1.89	V
Power Consumption (VDDA33)			850		μA
Power Consumption (VDDA18)			35		μA

(1) VDDA33 is the voltage on the corresponding power-supply pin(s) on the IC.

7.7.6 PMM

over operating junction temperature range (unless otherwise noted)

GROUP	PARAMETER	MIN	TYP	MAX	UNIT
	Power supply (VDDA33)	2.7/2.93	3.3	3.46	V
Bandgap	V _{BGREF} trimming	1.211	1.213*	1.215	V
	V _{BGREF} trimmed	1.195	1.213*	1.231	V
	V _{BGREF} untrimmed	1.152	1.213*	1.274	V
	V _{BGREF} trim steps		2		mV
	V _{REF} trimming	0.898	0.9	0.902	V
	V _{REF} trimmed	0.886	0.9	0.914	V
	V _{REF} untrimmed	0.855	0.9	0.945	V
	I _{REF} trimming	97	100	103	uA
	I _{REF} trimmed	85	100	115	uA
	I _{REF} untrimmed	50	100	150	uA
	I _{REF} trim steps		1.5		uA
	Power up time			200	uS
	Power consumption (VDDA33)		200		uA
	1.8V LDO	DC accuracy	1.764	1.8	1.836
Trim Target		1.797	1.8	1.803	V
Transient load regulation		1.71	1.8	1.89	V
Untrimmed Accuracy		1.62	1.8	1.98	V
DC Load regulation				5	mV
Load current		0		60	mA
Power up time				800	uS
Inrush current				150	mA
External decap		- 20%	4.7	20%	uF
Power consumption (VDDA33)			415		uA
ADC Reference		DC accuracy	- 2%	1.8	2%
	Trim target	TBD	1.8	TBD	mV
	Output Noise		TBD		
	Load regulation	- 1		1	mV
	Load current	0		5	mA
	Transient Load regulation	- 250		250	uV
	Power up time			800	uS
	Inrush current			80	mA
	External decap	- 20%	4.7	20%	uF
	Power consumption (VDDA33)		100		uA

7.8 VPP Specifications for One-Time Programmable (OTP) eFuses

This section specifies the operating conditions required for programming the OTP eFuses.

7.8.1 VPP Specifications

over recommended operating conditions (unless otherwise noted)

PARAMETER	DESCRIPTION	TEST CONDITIONS	MIN	NOM	MAX	UNIT
VDD	Supply voltage range for the core domain during OTP operation	Normal Operation (OPP100)	1.140	1.200	1.260	V
VPP	Supply voltage range for the eFuse ROM domain	Normal Operation (OPP100)	No Connection			V
	Supply voltage range for the eFuse ROM domain during OTP programming	OTP Programming	1.65	1.7	1.75	V
$I_{(VPP)}$	VPP Current	$I_{(VPP)}$			100	mA
T_A	Ambient Temperature	Ambient Temperature	0	30	50	°C

7.8.2 Hardware Requirements

The following hardware requirements must be met when programming keys in the OTP eFuses:

- The VPP power supply must be disabled when not programming OTP registers.
- The VPP power supply must be ramped up after the proper device power-up sequence (for more details, see [节 7.10.2, Power-On and Reset Sequencing](#)).

7.8.3 Programming Sequence

Programming sequence for OTP eFuses:

- Power on the board per the power-up sequencing. No voltage should be applied on the VPP terminal during power up and normal operation.
- Load the OTP write software required to program the eFuse (contact your local TI representative for the OTP software package).
- Apply the voltage on the VPP terminal according to the specification in [节 7.8.1](#).
- Run the software that programs the OTP registers.
- After validating the content of the OTP registers, remove the voltage from the VPP terminal.

7.8.4 Impact to Your Hardware Warranty

You accept that e-Fusing the TI Devices with security keys permanently alters them. You acknowledge that the e-Fuse can fail, for example, due to incorrect or aborted program sequence or if you omit a sequence step. Further the TI Device may fail to secure boot if the error code correction check fails for the Production Keys or if the image is not signed and optionally encrypted with the current active Production Keys. These types of situations will render the TI Device inoperable and TI will be unable to confirm whether the TI Devices conformed to their specifications prior to the attempted e-Fuse.

CONSEQUENTLY, TI WILL HAVE NO LIABILITY (WARRANTY OR OTHERWISE) FOR ANY TI DEVICES THAT HAVE BEEN e-FUSED WITH SECURITY KEYS.

7.9 Thermal Resistance Characteristics

This section provides the thermal resistance characteristics used on this device.

For reliability and operability concerns, the maximum junction temperature of the device has to be at or below the T_J value identified in 节 7.4, *Recommended Operating Conditions*.

7.9.1 Package Thermal Characteristics

表 7-1. ZCZ Package Thermal Resistance Characteristics

It is recommended to perform thermal simulations at the system level with the worst case device power consumption.

PARAMETER	DESCRIPTION	°C/W ^{(1) (2)}
$R_{\theta JC}$	Junction-to-case	5.6
$R_{\theta JB}$	Junction-to-board	5.7
$R_{\theta JA}$	Junction-to-free air	18.6
Ψ_{JT}	Junction-to-package top	0.1
Ψ_{JB}	Junction-to-board	5.6

(1) These values are based on a JEDEC defined 2S2P system (with the exception of the Theta JC [$R_{\theta JC}$] value, which is based on a JEDEC defined 1S0P system) and will change based on environment as well as application. For more information, see these EIA/ JEDEC standards:

- JESD51-2, Integrated Circuits Thermal Test Method Environment Conditions - Natural Convection (Still Air)
- JESD51-3, Low Effective Thermal Conductivity Test Board for Leaded Surface Mount Packages
- JESD51-6, Integrated Circuit Thermal Test Method Environmental Conditions - Forced Convection (Moving Air)
- JESD51-7, High Effective Thermal Conductivity Test Board for Leaded Surface Mount Packages
- JESD51-9, Test Boards for Area Array Surface Mount Packages

(2) °C/W = degrees Celsius per watt.

7.10 Timing and Switching Characteristics

备注

The default SLEWRATE settings in each pad configuration register must be used to ensure timings, unless specific instructions are given otherwise.

7.10.1 Timing Parameters and Information

The timing parameter symbols used in *Timing and Switching Characteristics* sections are created in accordance with JEDEC Standard 100. To shorten the symbols, some pin names and other related terminologies have been abbreviated in 表 7-2:

表 7-2. Timing Parameters Subscripts

SYMBOL	PARAMETER
c	Cycle time (period)
d	Delay time
dis	Disable time
en	Enable time
h	Hold time
su	Setup time
START	Start bit
t	Transition time
v	Valid time
w	Pulse duration (width)
X	Unknown, changing, or don't care level
F	Fall time
H	High
L	Low
R	Rise time
V	Valid
IV	Invalid
AE	Active Edge
FE	First Edge
LE	Last Edge
Z	High impedance

7.10.2 Power-On and Reset Sequencing

AM263x attempts to simplify the power reset requirements from previous Sitara MCU devices. There is no sequencing requirement with respect to the primary core digital VDD 1.2-V and I/O power 3.3-V rails. A pair of on-die LDO are supplied through the VDDS33 power net. These on-die LDO generate the required VDDS1V8 and VDDA1V8 1.8V digital and analog power. The AM263x does require the minimum ramp time be respected for 3.3-V power-on. Additional PORz and SOP boot mode latch timing must be respected by the EVM design as well. 图 7-1 describes the device power-up sequencing.

表 7-3. AM263x Power-On Sequencing

TIMING PARAMETER	MIN (ms)	MAX (ms)	COMMENTS
t _{Startup}	-	-	Time for 1.2-V and 3.3-V DC-DC converters to startup after initial 5.0-V power on. This is an arbitrary amount of time - no constraint imposed by the device.
t _{PGood}	-	-	Time for Power Good signals to be generated from DC-DC converters after rails are stable. This is an arbitrary amount of time - no constraint imposed by the device.

表 7-3. AM263x Power-On Sequencing (continued)

TIMING PARAMETER	MIN (ms)	MAX (ms)	COMMENTS
t_{Ramp_3V3}	0.1		Ramp time of the VDDS3V3 and VDDA3V3 supplies. This is a requirement imposed by the device.
t_{PORz}	-	-	Time from 1.2-V and 3.3-V power good generation to de-assertion of PORz. This is an arbitrary amount of time - no constraint imposed by the device.
$t_{SOP_Sampled}$	1.0		Time from PORz de-assertion until the SOP[3:0] pins are sampled. This is a requirement imposed by the device.
t_{SU_SOP}	TBD	TBD	Setup time relative to SOP sample time.
t_{H_SOP}	TBD	TBD	Hold time relative to SOP sample time.
$t_{WARMRSTz}$	2.0	-	Time from PORz de-assertion until the device de-asserts the WARMRESETz signal.
t_{XO_Stable}	TBD	TBD	Time from PORz de-assertion until the device has a stable reference frequency from the attached XTAL.

ADVANCE INFORMATION



图 7-1. Power-Up Sequencing

7.10.2.1 Power Reset Sequence Description

The following set of steps shall occur on the EVM and AM263x to boot the device from power-on reset.

1. PORz is held low by the external power supply monitor
2. VDD core digital 1.2V and VDDS3V3/VDDA3V3 3.3V supplies ramp to their nominal voltages
 - a. This requires a logical AND be applied to the power good signal generated from each supply
3. SOP[3:0] pins held in their boot latch state
4. After PCB supplied power nets are stable, the external supply monitor will de-assert PORz
5. Device will startup 1.8V on-die LDO
6. After internal supply monitors show externally and internally generated supplies are stable, the SOP[3:0] pin states are latched
7. Device starts XTAL oscillator
8. R5F cores are unhalted and SOP selected boot ROM execution begins

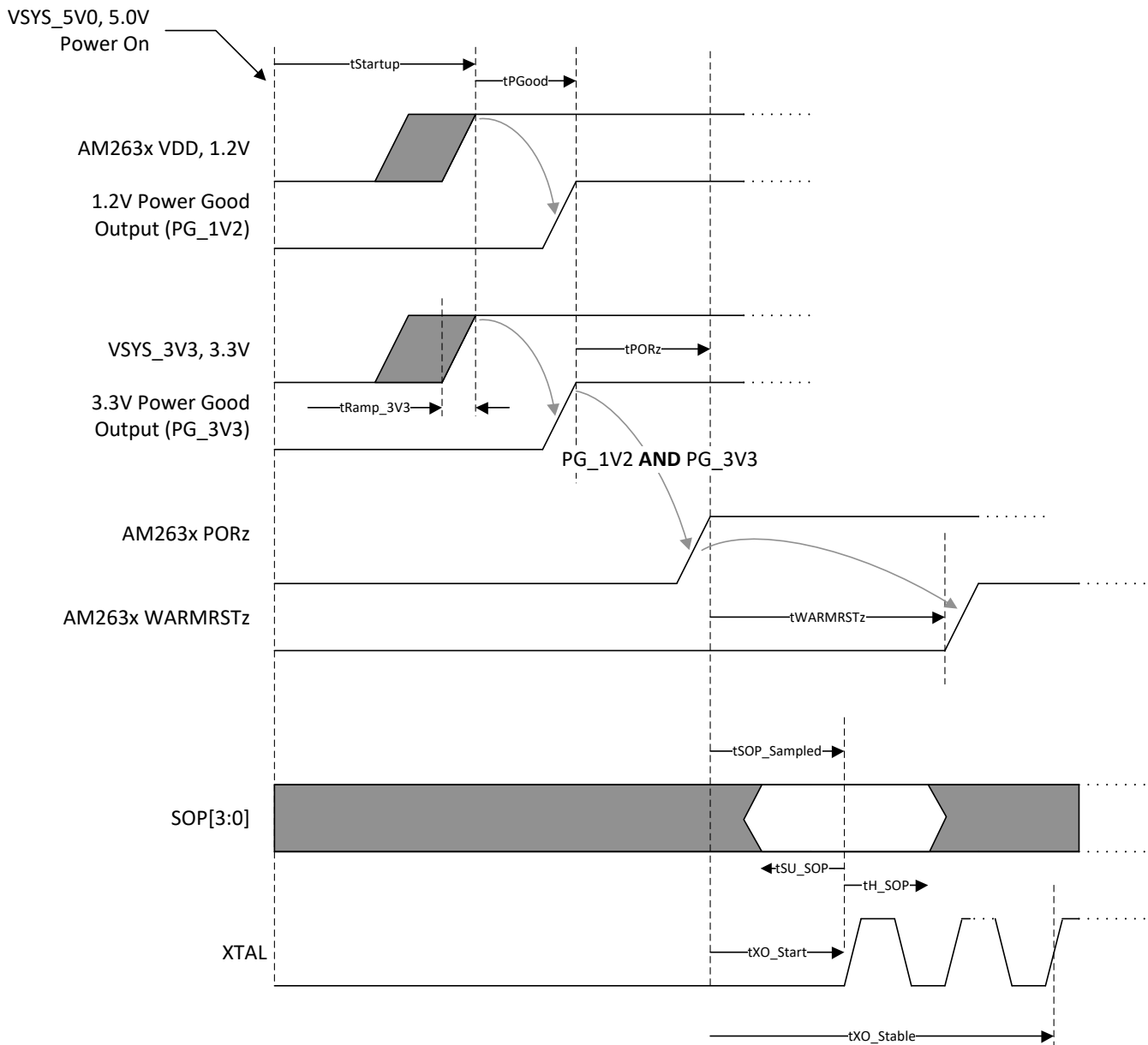
7.10.3 Clock Specifications

7.10.3.1 Input Clocks / Oscillators

7.10.3.1.1 Crystal Oscillator Parameters

PARAMETER		MIN	TYP	MAX	UNIT
F _{xtal}	Crystal Parallel Resonance Frequency (Fundamental mode oscillation only)	- 50ppm	25	50ppm	MHz
CC1	Capacitance of C _{L1} + C _{PCBX1}	12		24	pF
CC2	Capacitance of C _{L2} + C _{PCBXO}	12		24	pF
C _{shunt}	Crystal Circuit Shunt Capacitance			5	pF
ESR _{xtal}	Crystal Effective Series Resistance			46	Ω

7.10.3.1.2 External Clock Characteristics

over recommended operating conditions (unless otherwise noted)

PARAMETER		MIN	TYP	MAX	UNIT
C _{Pkg}	Shunt Capacitance of pkg		0.01		pF
P _{xtal}	Power dissipation	$0.5 \times \text{ESR} \times (2 \times \pi \times F_{\text{xtal}} \times C_L \times 1.8)^2$			W
t _s	Start up time		1.5		ms

7.10.4 Peripherals

7.10.4.1 CPSW3G

For more details about features and additional description information on the device Gigabit Ethernet MAC, see the corresponding subsections within *Signal Descriptions* and *Detailed Description* sections.

7.10.4.1.1 CPSW3G MDIO Timing

CPSW3G MDIO Timing Conditions

PARAMETER		MIN	MAX	UNIT
INPUT CONDITIONS				
SR _i	Input Slew Rate	0.9	3.6	V/ns
OUTPUT CONDITIONS				
C _L	Output Load Capacitance	10	470	pF

CPSW3G MDIO Timing Requirements

NO.	PARAMETER	DESCRIPTION	MIN	MAX	UNIT
MDIO1	t _{sw} (MDIO-MDC)	Setup time, MDIO_DATA valid before MDIO_CLK high	90		ns
MDIO2	t _h (MDC-MDIO)	Hold time, MDIO_DATA valid after MDIO_CLK high	0		ns

CPSW3G MDIO Switching Characteristics

NO.	PARAMETER	DESCRIPTION	MIN	MAX	UNIT
MDIO3	t _c (MDC)	Cycle time, MDIO_CLK	400		ns
MDIO4	t _w (MDCH)	Pulse duration, MDIO_CLK high	160		ns
MDIO5	t _w (MDCL)	Pulse duration, MDIO_CLK low	160		ns
MDIO7	t _d (MDC_MDIO)	Delay time, MDIO_CLK low to MDIO_DATA valid	-150	150	ns

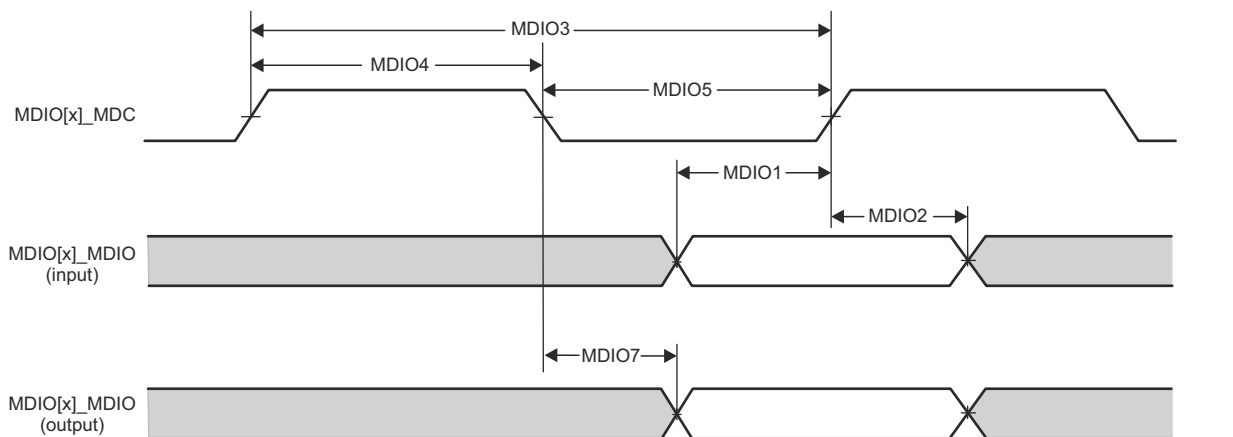

CPSW2G_MDIO_TIMING_01

图 7-2. CPSW3G MDIO Timing Requirements and Switching Characteristics

7.10.4.1.2 CPSW3G RMIITiming

CPSW3G RMIITiming Conditions

PARAMETER		MIN	MAX	UNIT
INPUT CONDITIONS				

PARAMETER		MIN	MAX	UNIT
SR _i	Input Slew Rate	VDD = 1.8V		V/ns
		VDD = 3.3V		V/ns
OUTPUT CONDITIONS				
C _L	Output Load Capacitance	3	25	pF

CPSW3G RMII[x]_REFCLK Timing Requirements - RMII Mode

NO.	PARAMETER	DESCRIPTION	MIN	MAX	UNIT
RMII1	t _c (REF_CLK)	Cycle time, REF_CLK	19.999	20	ns
RMII2	t _w (REF_CLKH)	Pulse duration, REF_CLK High	7	13	ns
RMII3	t _w (REF_CLKL)	Pulse duration, REF_CLK Low	7	13	ns



图 7-3. CPSW3G RMII[x]_REF_CLK Timing Requirements - RMII Mode

CPSW3G RMII[x]_RXD[1:0], RMII[x]_CRS_DV, and RMII[x]_RXER Timing Requirements - RMII Mode

NO.	PARAMETER	DESCRIPTION	MIN	MAX	UNIT
RMII4	t _{su} (RXD-REF_CLK)	Setup time, RXD[1:0] valid before REF_CLK	4		ns
	t _{su} (CRS_DV-REF_CLK)	Setup time, CRS_DV valid before REF_CLK	4		ns
	t _{su} (RX_ER-REF_CLK)	Setup time, RX_ER valid before REF_CLK	4		ns
RMII5	t _h (REF_CLK-RXD)	Hold time, RXD[1:0] valid after REF_CLK	2		ns
	t _h (REF_CLK-CRS_DV)	Hold time, CRS_DV valid after REF_CLK	2		ns
	t _h (REF_CLK-RX_ER)	Hold time, RX_ER valid after REF_CLK	2		ns

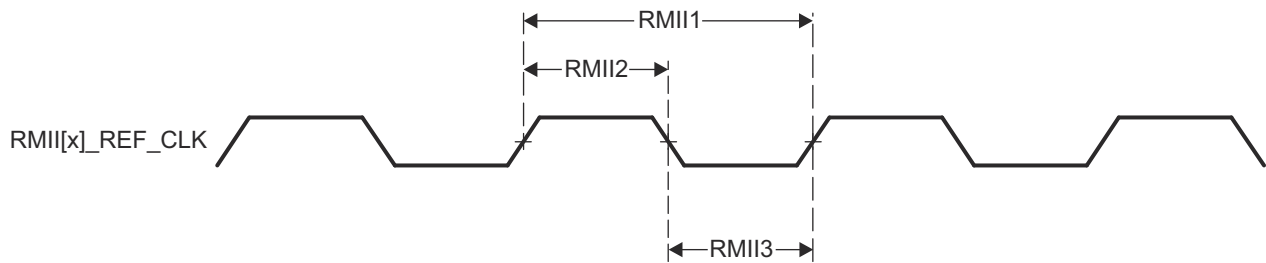

图 7-4. CPSW3G RMII[x]_RXD[1:0], RMII[x]_CRS_DV, RMII[x]_RX_ER Timing Requirements - RMII Mode

CPSW3G RMII[x]_TXD[1:0], and RMII[x]_TXEN Switching Characteristics - RMII Mode

NO.	PARAMETER	DESCRIPTION	MIN	MAX	UNIT
RMII6	t _d (REF_CLK-TXD)	Delay time, REF_CLK High to TXD[1:0] valid	2	10	ns
	t _d (REF_CLK-TXEN)	Delay time, REF_CLK to TXEN valid	2	10	ns

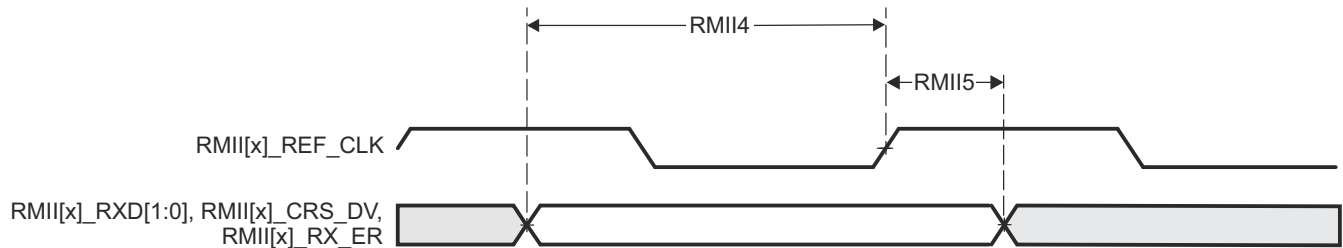

图 7-5. RMII[x]_TXD[1:0], and RMII[x]_TX_EN Switching Characteristics - RMII Mode

7.10.4.1.3 CPSW3G RGMII Timing

CPSW3G RGMII Timing Conditions

PARAMETER		MIN	MAX	UNIT
INPUT CONDITIONS				
SR_i	Input Slew Rate	2.64	5	V/ns
OUTPUT CONDITIONS				
C_L	Output Load Capacitance	2	20	pF
PCB Connectivity Requirements				
t_d (Trace Mismatch Delay)	Propogation Delay mismatch across all traces	RGMII[x]_RXC RGMII[x]_RD[3:0] RGMII[x]_RX_CTL	50	pF
		RGMII[x]_TXC RGMII[x]_TD[3:0] RGMII[x]_TX_CTL	50	pF

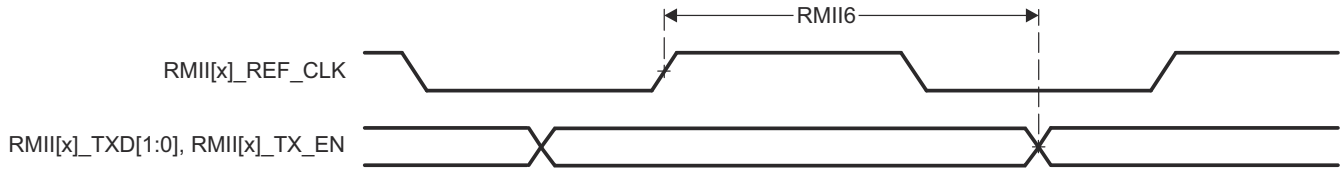
CPSW3G RGMII[x]_RCLK Timing Requirements - RGMII Mode

NO.	PARAMETER	DESCRIPTION	MODE	MIN	MAX	UNIT
RGMII1	$t_{c(RXC)}$	Cycle time, RXC	10Mbps	360	440	ns
			100Mbps	36	44	ns
			1000Mbps	7.2	8.8	ns
RGMII2	$t_w(RXCH)$	Pulse duration, RXC high	10Mbps	160	240	ns
			100Mbps	16	24	ns
			1000Mbps	3.6	4.4	ns
RGMII3	$t_w(RXCL)$	Pulse duration, RXC low	10Mbps	160	240	ns
			100Mbps	16	24	ns
			1000Mbps	3.6	4.4	ns

CPSW3G RGMII[x]_RD[3:0], and RGMII[x]_RCTL Timing Requirements

NO.	PARAMETER	DESCRIPTION	MODE	MIN	MAX	UNIT
RGMII4	$t_{su(RD-RXC)}$	Setup time, RD[3:0] valid before RXC high/low	10Mbps	1		ns
			100Mbps	1		ns
			1000Mbps	1		ns
	$t_{su(RX_CTL-RXC)}$	Setup time, RX_CTL valid before RXC high/low	10Mbps	1		ns
			100Mbps	1		ns
			1000Mbps	1		ns

NO.	PARAMETER	DESCRIPTION	MODE	MIN	MAX	UNIT
RGMII5	$t_{h(RXC-RD)}$	Hold time, RD[3:0] valid after RXC high/low	10Mbps	1		ns
			100Mbps	1		ns
			1000Mbps	1		ns
	$t_{h(RXC-RX_CTL)}$	Hold time, RX_CTL valid after RXC high/low	10Mbps	1		ns
			100Mbps	1		ns
			1000Mbps	1		ns

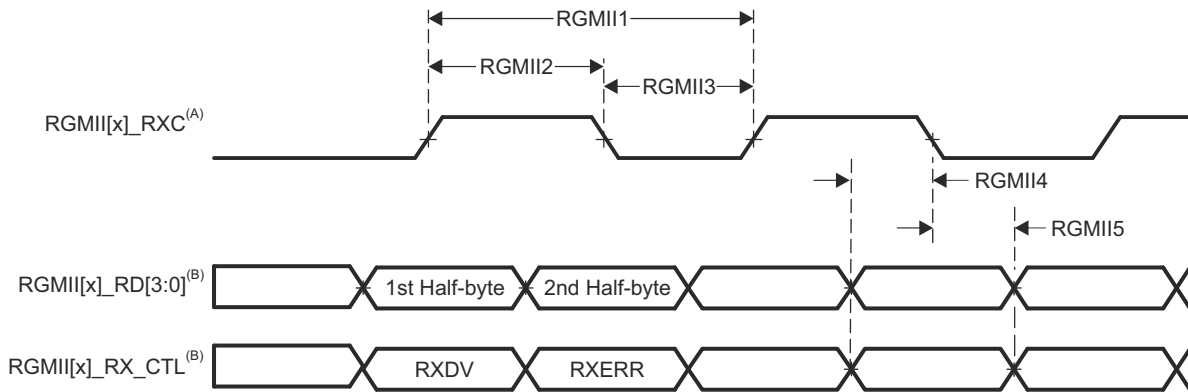

- A. RGMII[x]_RXC must be externally delayed relative to the data and control pins.
 B. Data and control information is received using both edges of the clocks. RGMII[x]_RD[3:0] carries data bits 3-0 on the rising edge of RGMII[x]_RXC and data bits 7-4 on the falling edge of RGMII[x]_RXC. Similarly, RGMII[x]_RX_CTL carries RXDV on rising edge of RGMII[x]_RXC and RXERR on falling edge of RGMII[x]_RXC.

图 7-6. CPSW3G RGMII[x]_RXC, RGMII[x]_RD[3:0], RGMII[x]_RX_CTL Timing Requirements - RGMII Mode

CPSW3G RGMII[x]_TCLK Switching Characteristics - RGMII Mode

NO.	PARAMETER	DESCRIPTION	MODE	MIN	MAX	UNIT
RGMII6	$t_{c(TXC)}$	Cycle time, TXC	10Mbps	360	440	ns
			100Mbps	36	44	ns
			1000Mbps	7.2	8.8	ns
RGMII7	$t_{w(TXCH)}$	Pulse duration, TXC high	10Mbps	160	240	ns
			100Mbps	16	24	ns
			1000Mbps	3.6	4.4	ns
RGMII8	$t_{w(TXCL)}$	Pulse duration, TXC low	10Mbps	160	240	ns
			100Mbps	16	24	ns
			1000Mbps	3.6	4.4	ns

CPSW3G RGMII[x]_TD[3:0], and RGMII[x]_TCTL Switching Characteristics - RGMII Mode

NO.	PARAMETER	DESCRIPTION	MODE	MIN	MAX	UNIT
RGMII9	$t_{osu(TD-TXC)}$	Output setup time, RGMII[x]_TD[3:0] valid to RGMII[x]_TXC high/low	10Mbps	1.2		ns
			100Mbps	1.2		ns
			1000Mbps	1.2		ns
	$t_{osu(TX_CTL-TXC)}$	Output setup time, RGMII[x]_TX_CTL valid to RGMII[x]_TXC high/low	10Mbps	1.2		ns
			100Mbps	1.2		ns
			1000Mbps	1.2		ns

NO.	PARAMETER	DESCRIPTION	MODE	MIN	MAX	UNIT
RGMII10	$t_{oh}(TXC-TD)$	Output hold time, RGMII[x]_TD[3:0] valid after RGMII[x]_TXC high/low	10Mbps	1.2		ns
			100Mbps	1.2		ns
			1000Mbps	1.2		ns
	$t_{oh}(TXC-TX_CTL)$	Output hold time, RGMII[x]_TX_CTL valid after RGMII[x]_TXC high/low	10Mbps	1.2		ns
			100Mbps	1.2		ns
			1000Mbps	1.2		ns

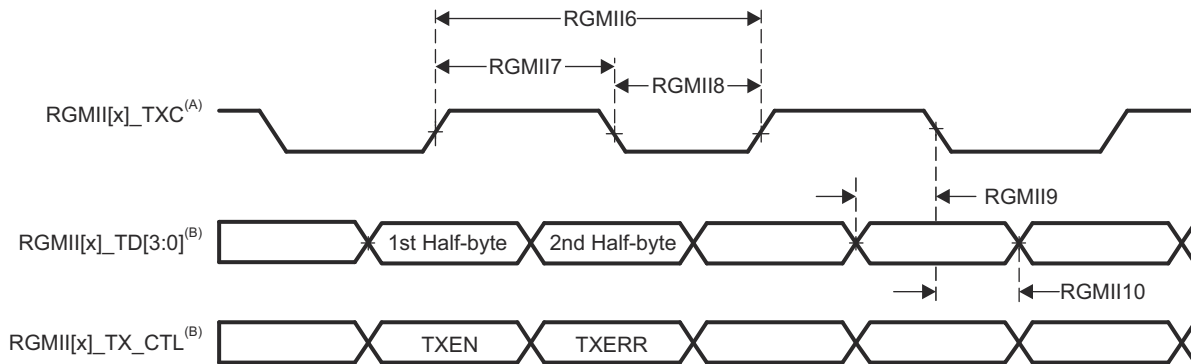

- A. TXC is delayed internally before being driven to the RGMII[x]_TXC pin. This internal delay is always enabled.
 B. Data and control information is received using both edges of the clocks. RGMII[x]_TD[3:0] carries data bits 3-0 on the rising edge of RGMII[x]_TXC and data bits 7-4 on the falling edge of RGMII[x]_TXC. Similarly, RGMII[x]_TX_CTL carries TXEN on rising edge of RGMII[x]_TXC and TXERR on falling edge of RGMII[x]_TXC.

图 7-7. CPSW3G RGMII[x]_TXC, RGMII[x]_TD[3:0], and RGMII[x]_TX_CTL Switching Characteristics - RGMII Mode

7.10.4.2 ECAP

For more information, see *Enhanced Capture (ECAP) Module* section in the device TRM.

eCAP Timing Conditions

PARAMETER		MIN	MAX	UNIT
INPUT CONDITIONS				
SR_i	Input Slew Rate	1	4	V/ns
OUTPUT CONDITIONS				
C_L	Output Load Capacitance	2	7	pF

eCAP Timing Requirements

NO.	PARAMETER	DESCRIPTION	MIN	MAX	UNIT
CAP1	$t_{w(CAP)}$	Capture input pulse width	Asynchronous	$(2 + X^{(2)}) \times P^{(1)}$	ns
			Synchronous	$(3 + X^{(2)}) \times P^{(1)}$	
			With input qualifier	$(2 + X^{(2)}) \times P^{(1)} + U^{(3)}$	

- (1) P = sysclk period in ns.
 (2) X = value of ECCTL0_TYPE3[QUALPRD] setting.
 (3) U = the input qualifier sampling window. See GPIO Electrical Data and Timing section for details on Input Qualifier Mode



图 7-8. ECAP Timings Requirements

eCAP Switching Characteristics

NO.	PARAMETER	DESCRIPTION	MIN	MAX	UNIT
CAP2	$t_w(\text{APWM})$	Pulse duration, APWMx output high/low	10		ns



图 7-9. ECAP Switching Characteristics

7.10.4.3 EPWM

For more information, see *Enhanced Pulse Width Modulation (EPWM) Module* section in the device TRM.

ePWM Timing Conditions

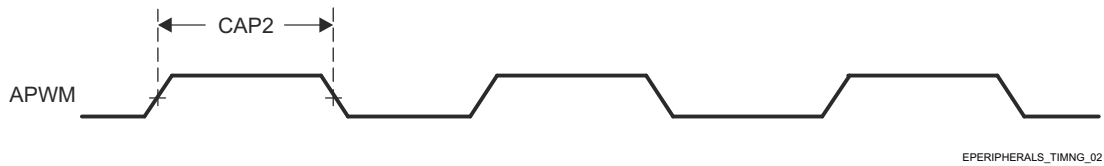
PARAMETER		MIN	MAX	UNIT
INPUT CONDITIONS				
SR_i	Input Slew Rate	1	4	V/ns
OUTPUT CONDITIONS				
C_L	Output Load Capacitance	2	7	pF

ePWM Timing Requirements

NO.	PARAMETER	DESCRIPTION	MIN	MAX	UNIT
PWM6	$t_w(\text{SYNClN})$	Pulse duration, EHRPWM_SYNCI	$2P^{(1)}$		ns
PWM7	$t_w(\text{TZ})$	Pulse duration, EHRPWM_TZn_IN low	$1P^{(1)}$		ns

(1) P = sysclk period in ns.



图 7-10. EPWM Timing Requirements

ePWM Switching Characteristics

NO.	PARAMETER	DESCRIPTION	MIN	MAX	UNIT
PWM1	$t_w(\text{PWM})$	Pulse duration, EHRPWM_A/B high/low	20		ns
PWM2	$t_w(\text{SYNCO})$	Pulse duration, EHRPWM_SYNCO	8P ⁽¹⁾		ns
PWM3	$t_d(\text{TZ-PWM})$	Delay time, EHRPWM_TZn_IN active to EHRPWM_A/B forced high/low		30	ns
PWM4	$t_d(\text{TZ-PWMZ})$	Delay time, EHRPWM_TZn_IN active to EHRPWM_A/B Hi-Z		30	ns
PWM5	$t_w(\text{SOCA/B})$	Pulse duration, EHRPWM_SOCA/B output	32P ⁽¹⁾		ns

(1) P = sysclk period in ns.

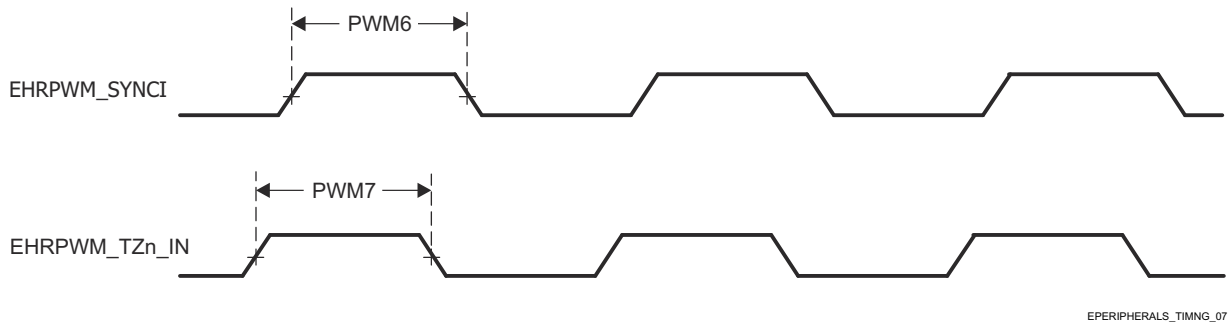
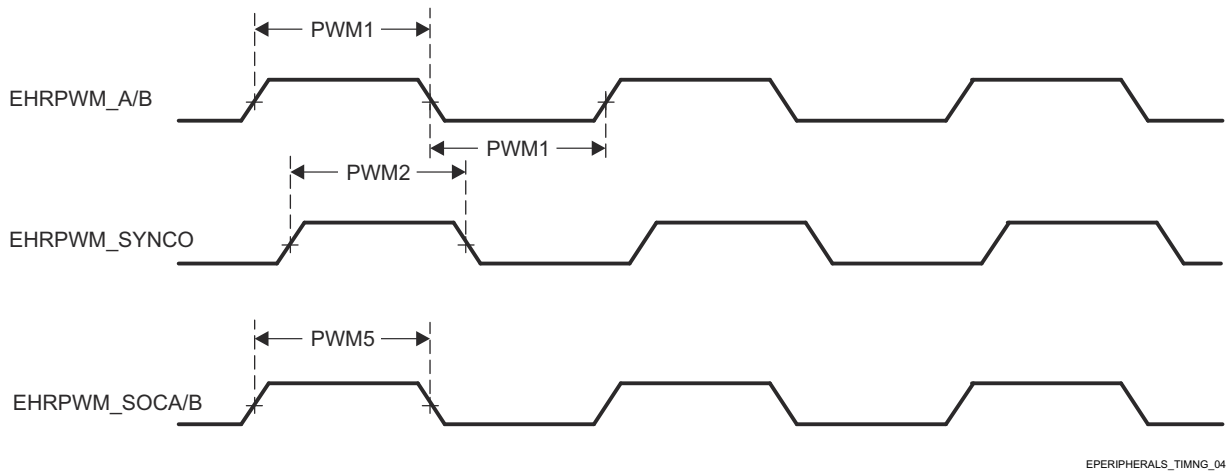

EPERIPHERALS_TIMING_04

图 7-11. EHRPWM Switching Characteristics

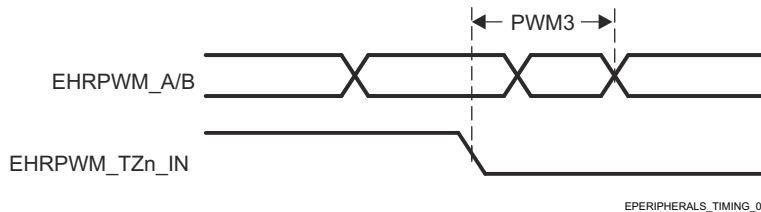

EPERIPHERALS_TIMING_05

图 7-12. EHRPWM_TZn_IN to EHRPWM_A/B Forced Switching Characteristics



图 7-13. EHRPWM_TZn_IN to EHRPWM_A/B Hi-Z Switching Characteristics

7.10.4.4 EQEP

For more information, see *Enhanced Quadrature Encoder Pulse (EQEP) Module* section in the device TRM.

eQEP Timing Conditions

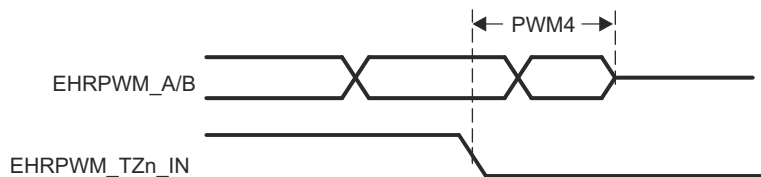
PARAMETER	MIN	MAX	UNIT
INPUT CONDITIONS			

PARAMETER		MIN	MAX	UNIT
SR _I	Input Slew Rate	1	4	V/ns
OUTPUT CONDITIONS				
C _L	Output Load Capacitance	2	7	pF

eQEP Timing Requirements

NO.	PARAMETER	DESCRIPTION		MIN	MAX	UNIT
QEP1	t _{w(QEPP)}	QEP input period	Synchronous ⁽³⁾	3P ⁽¹⁾		ns
			With input qualifier	2 × (P ⁽¹⁾ + U ⁽²⁾)		
QEP2	t _{w(INDEXH)}	QEP Index Input High time	Synchronous ⁽³⁾	2 + 3P ⁽¹⁾		ns
			With input qualifier	2P ⁽¹⁾ + U ⁽²⁾		
QEP3	t _{w(INDEXL)}	QEP Index Input Low time	Synchronous ⁽³⁾	3P ⁽¹⁾		ns
			With input qualifier	2P ⁽¹⁾ + U ⁽²⁾		
QEP4	t _{w(STROBH)}	QEP Strobe High time	Synchronous ⁽³⁾	3P ⁽¹⁾		ns
			With input qualifier	2P ⁽¹⁾ + U ⁽²⁾		
QEP5	t _{w(STROBL)}	QEP Strobe Input Low time	Synchronous ⁽³⁾	3P ⁽¹⁾		ns
			With input qualifier	2P ⁽¹⁾ + U ⁽²⁾		

- (1) P = sysclk period in ns.
- (2) U = the input qualifier sampling window. See GPIO Electrical Data and Timing section for details on Input Qualifier Mode.
- (3) The GPIO GPxQSELn Asynchronous mode should not be used for eQEP module input pins.



图 7-14. EQEP Timing Requirements

eQEP Switching Characteristics

NO.	PARAMETER	DESCRIPTION	MIN	MAX	UNIT
QEP6	t _{d(CNTR)xin}	Delay time, external clock to counter increment		4 + U ⁽²⁾ + 6P ⁽¹⁾	ns
QEP7	t _{d(PCS-OUT)QEP}	Delay time, QEP input edge to position compare sync output		4 + U ⁽²⁾ + 7P ⁽¹⁾ + 4	ns

- (1) P = sysclk period in ns.
- (2) U = the input qualifier sampling window. See GPIO Electrical Data and Timing section for details on Input Qualifier Mode.

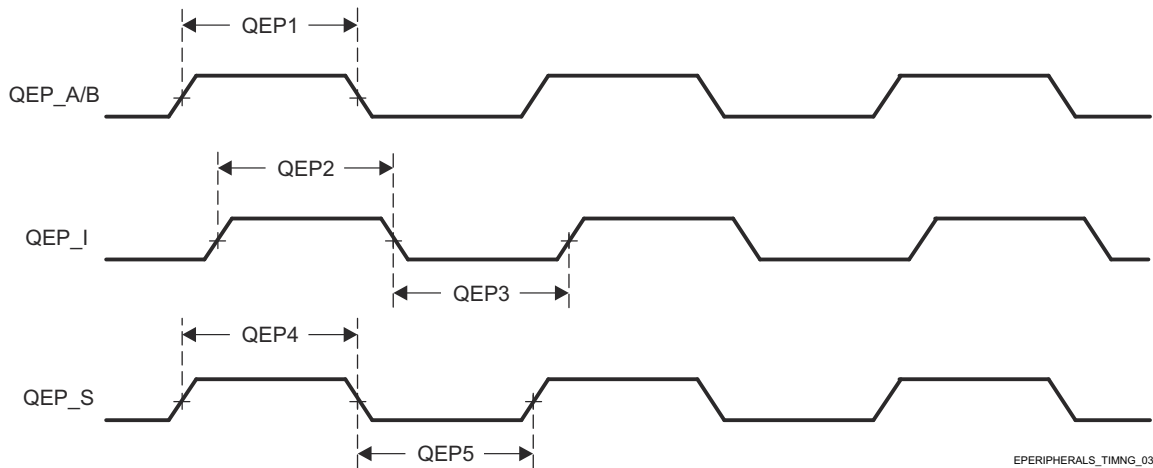
7.10.4.5 FSI

For more information, see *Fast Serial Interface* section in the device TRM.

FSI Timing Conditions

PARAMETER		MIN	MAX	UNIT
INPUT CONDITIONS				
SR _I	Input Slew Rate	0.8	4	V/ns
OUTPUT CONDITIONS				
C _L	Output Load Capacitance	1	7	pF

FSIRX Timing Requirements

NO.	PARAMETER	DESCRIPTION	MIN	MAX	UNIT
FSIR1	t _{c(RX_CLK)}	Cycle time, FSIRXn_CLK	16.67		ns
FSIR2	t _{w(RX_CLK)}	Pulse width, FSIRXn_CLK low or FSIRXn_CLK high	0.35P ⁽¹⁾ - 1	0.65P ⁽¹⁾ + 1	ns
FSIR3	t _{d(RX_D - RX_CLK)}	Delay time, FSIRXn_D[0:1] valid before FSIRXn_CLK	1.7		ns
FSIR4	t _{h(RX_CLK - RX_D)}	Hold time with respect to both edges of FSIRXn_CLK	2		ns

(1) P = T_{c(RXCLK)} = RX Interface clock period in ns.



图 7-15. FSI Timing Requirements

FSIRX Switching Characteristics

NO.	PARAMETER	DESCRIPTION	MIN	MAX	UNIT
FSIR5	t _{d(RX_CLK)}	FSIRXn_CLK delay compensation at RX_DLYLINE_CTRL[RXCLK_DLY]=31	10	30	ns
FSIR6	t _{d(RX_D0)}	FSIRXn_D0 delay compensation at RX_DLYLINE_CTRL[RXCLK_DLY]=31	10	30	ns
FSIR7	t _{d(RX_D1)}	FSIRXn_D1 delay compensation at RX_DLYLINE_CTRL[RXCLK_DLY]=31	10	30	ns
FSIR8	t _{d(DELAY_ELEMENT)}	Incremental delay of each delay line element for FSIRXn_CLK, FSIRXn_D0, and FSIRXn_D1	0.3	1	ns
FSIR_TD M1	t _{skew(RX_CLK-TX_TDM_D)}	Delay skew between FSIRXn_TDM_CLK delay and FSIRXn_TDM_D[0:1]	-3	3	ns
FSIR_TD M2	t _{skew(RX_CLK-TX_TDM_CLK)}	Delay time, FSIRXn_CLK input to FSITXn_TDM_CLK output	2	12	ns
FSIR_TD M3	t _{skew(RX_D0-TX_TDM_D0)}	Delay time, FSIRXn_D0 input to FSITXn_TDM_D0 output	2	12	ns
FSIR_TD M4	t _{skew(RX_D1-TX_TDM_D1)}	Delay time, FSIRXn_D1 input to FSITXn_TDM_D1 output	2	12	ns

FSITX Switching Characteristics

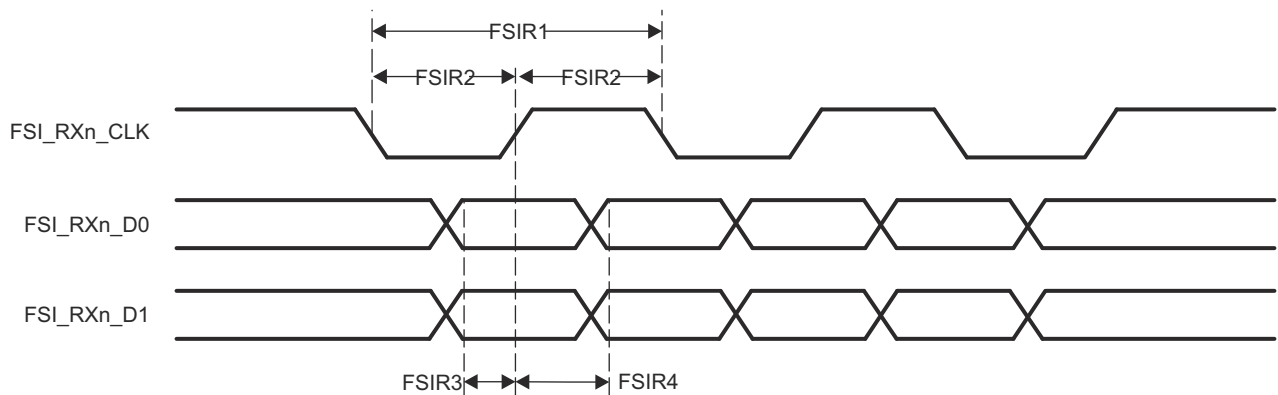
NO.	PARAMETER	DESCRIPTION	MIN	MAX	UNIT
FSIT1	$t_{c(TX_CLK)}$	Cycle time, FSITXn_CLK	16.67		ns
FSIT2	$t_{w(TX_CLK)}$	Pulse width, FSITXn_CLK low or FSITXn_CLK high	$0.5P^{(1)} - 1$	$0.5P^{(1)} + 1$	ns
FSIT3	$t_{d(TX_CLK-TX_D)}$	Delay time, FSITXn_Dx valid after FSITXn_CLK high or FSITXn_CLK low	$0.25P^{(1)} - 2$	$0.25P^{(1)} + 2$	ns
FSIT4	$t_{d(TXCLKL)}$	FSITXn_CLK delay compensation at TX_DLYLINE_CTRL[TXCLK_DLY]=31	9.95	30	ns
FSIT5	$t_{d(TX_D0)}$	FSITXn_D0 delay compensation at TX_DLYLINE_CTRL[TXCLK_DLY]=31	9.95	30	ns
FSIT6	$t_{d(TX_D1)}$	FSITXn_D1 delay compensation at TX_DLYLINE_CTRL[TXCLK_DLY]=31	9.95	30	ns
FSIT7	$t_{d(TX_DELAY_ELEMENT)}$	Incremental delay of each delay line element for FSITXn_CLK, FSITXn_D0, and FSITXn_D1	0.3	1	ns
FSIT_TD M1	$t_{skew(TX_TDM_CLK-TX_TDM_D)}$	Delay skew introduced between FSITXn_TDM_CLK delay and FSITXn_TDM_D[0:1] delays	- 2.5	2.5	ns
FSIT_TD M2	$t_{skew(TX_TDM_CLK-TX_CLK)}$	Delay time, FSITXn_TDM_CLK input to FSITXn_CLK output	2	12	ns
FSIT_TD M3	$t_{skew(TX_TDM_D0-TX_D0)}$	Delay time, FSITXn_TDM_D0 input to FSITXn_D0 output	2	12	ns
FSIT_TD M4	$t_{skew(TX_TDM_D1-TX_D1)}$	Delay time, FSITXn_TDM_D1 input to FSITXn_D1 output	2	12	ns

(1) $P = t_{c(TX_CLK)}$ = FSITX Interface clock period in ns.



图 7-16. FSI Switching Characteristics - FSI Mode

FSITX SPI Signaling Mode Switching Characteristics

NO.	PARAMETER	DESCRIPTION	MIN	MAX	UNIT
FSIT4	$t_{c(TX_CLK)}$	Cycle time, FSITXn_CLK	16.67		ns
FSIT5	$t_{w(TX_CLK)}$	Pulse width, FSITXn_CLK low or FSITXn_CLK high	$0.5P^{(1)} - 1$	$0.5P^{(1)} + 1$	ns
FSIT6	$t_{d(TX_CLKH - TX_D0)}$	Delay time, FSITXn_CLK high to FSITXn_D0 valid		3	ns
FSIT7	$t_{d(TX_D1-TX_CLK)}$	Delay time, FSITXn_D1 low to FSITXn_CLK high	$P^{(1)} - 3$		ns

NO.	PARAMETER	DESCRIPTION	MIN	MAX	UNIT
FSIT8	$t_{d(TX_CLK-TX_D1)}$	Delay time, FSITXn_CLK low to FSITXn_D1 high	$P^{(1)}$		ns

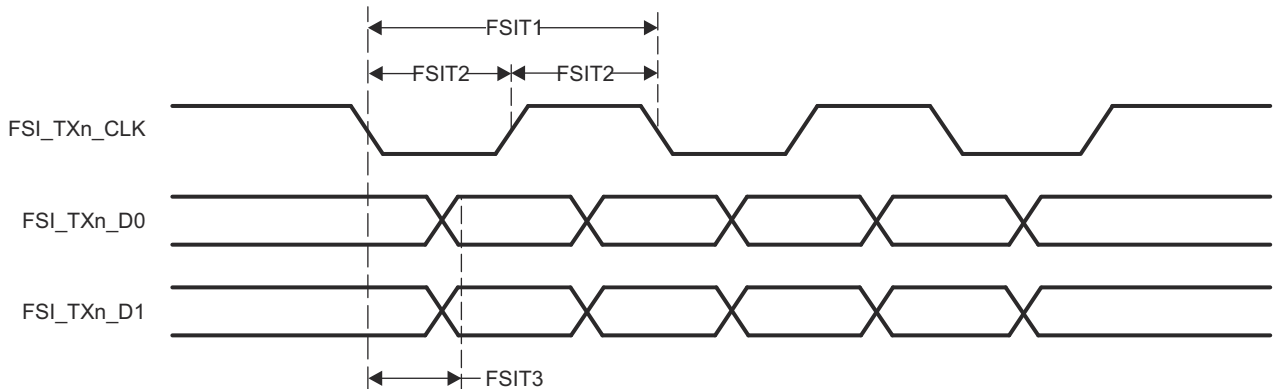
(1) $P = t_{c(TX_CLK)}$ = FSITX Interface clock period in ns.



图 7-17. FSI Switching Characteristics - SPI Mode

7.10.4.6 GPIO

For more details about features and additional description information on the device GPIO, see the corresponding subsections within *Signal Descriptions* and *Detailed Description* sections.

For more information, see *General-Purpose Interface (GPIO)* section in the device TRM.

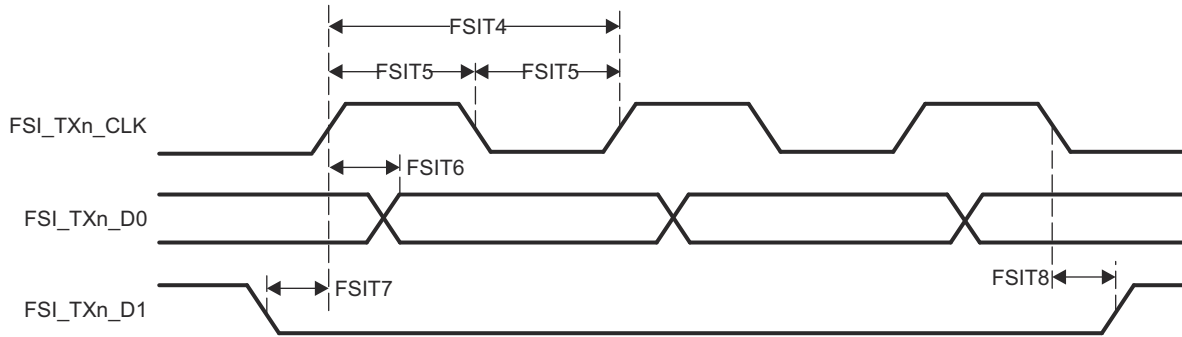
GPIO Timing Conditions

PARAMETER		BUFFER TYPE	MIN	MAX	UNIT
INPUT CONDITIONS					
SR _i	Input Slew Rate		0.75	6.6	V/ns
OUTPUT CONDITIONS					
C _L	Output Load Capacitance	LVC MOS	3	10	pF
		I2C OD FS ⁽¹⁾	3	10	pF

(1) A pull-up resistor is required for buffer type I2C OD FS.

GPIO Timing Requirements

NO.	PARAMETER	DESCRIPTION	BUFFER TYPE	MIN	MAX	UNIT
D3	$t_{w(GPIO_IN)}$	Minimum Input Pulse Width	LVC MOS	$2P^{(1)} + 2$		ns
D4			I2C OD FS ⁽²⁾	$2P^{(1)} + 2$		ns

(1) P = functional clock period in ns.

(2) A pull-up resistor is required for buffer type I2C OD FS.

GPIO Switching Characteristics

NO.	PARAMETER	DESCRIPTION	BUFFER TYPE	MIN	MAX	UNIT
D1	$t_{w(GPIO_OUT)}$	Minimum Output Pulse Width	LVC MOS	$0.975P^{(1)} - 2$		ns
D2	$t_{w(GPIO_OUT)}$	Minimum Output Pulse Width Low	I2C OD FS ⁽²⁾	$2P^{(1)} + 160$		ns
D3	$t_{w(GPIO_OUT)}$	Minimum Output Pulse Width High	I2C OD FS ⁽²⁾	$2P^{(1)} + 160$		ns

(1) P = functional clock period in ns.

(2) A pull-up resistor is required for buffer type I2C OD FS.

7.10.4.7 GPMC

For more details about features and additional description information on the device General-Purpose Memory Controller, see the corresponding subsections within *Signal Descriptions* and *Detailed Description* sections.

For more information, see *General-Purpose Memory Controller (GPMC)* section in the device TRM.

GPMC Timing Conditions

PARAMETER		MIN	MAX	UNIT	
INPUT CONDITIONS					
SR _i	Input Slew Rate	1.65	4	V/ns	
OUTPUT CONDITIONS					
C _L	Output Load Capacitance	3	20	pF	
PCB CONNECTIVITY REQUIREMENTS					
t _d (Trace Delay)	Propagation delay of each trace	100MHz	140	720	ps
t _d (Trace Mismatch Delay)	Propagation delay mismatch across all traces		200		ps

GPMC/NOR Flash Timing Requirements - Synchronous Mode 100MHz

(1) (2)

NO.	PARAMETER	DESCRIPTION	MODE	MIN	MAX	UNIT
F12	t _{su} (dV-clkH)	Setup time, GPMC0_AD[31:0] valid before GPMC0_CLK high	div_by_1_mode ⁽⁴⁾	1.81		ns
			not_div_by_1_mode ⁽⁵⁾	1.06		ns
F13	t _h (clkH-dV)	Hold time, GPMC0_AD[31:0] valid after GPMC0_CLK high	div_by_1_mode ⁽⁴⁾	2.29		ns
			not_div_by_1_mode ⁽⁵⁾	2.29		ns
F21	t _{su} (waitV-clkH)	Setup time, GPMC0_WAIT[x] ⁽³⁾ valid before GPMC0_CLK high	div_by_1_mode ⁽⁴⁾	1.81		ns
			not_div_by_1_mode ⁽⁵⁾	1.06		ns
F22	t _h (clkH-waitV)	Hold time, GPMC0_WAIT[x] ⁽³⁾ valid after GPMC0_CLK high	div_by_1_mode ⁽⁴⁾	2.29		ns
			not_div_by_1_mode ⁽⁵⁾	2.29		ns

- (1) 100MHz GPMC_FCLK selected - CTRLMMR_GPMC_CLKSEL[0] CLK_SEL = 1 = MAIN_PLL2_HSDIV7_CLKOUT (100/60 MHz).
- (2) Trace length from GPMC pins to device assumed to be less than 4" and length matched to within 200ps for 100MHz Synchronous Mode.
- (3) In GPMC_WAIT[x], x is equal to 0 or 1.
- (4) In div_by_1_mode, GPMC0_CLK refers to either GPMC0_CLKOUT or GPMC0_FCLK_MUX (free-running). Both signals are pin-muxed to the same pin.
GPMC_CONFIG1_i Register: GPMCFCLKDIVIDER = 0h:
- GPMC0_CLK frequency = GPMC_FCLK frequency
- (5) In not_div_by_1_mode, GPMC0_CLK only refers to GPMC0_CLKOUT. GPMC0_FCLK_MUX cannot be clock divided to match the GPMC0_CLKOUT frequency if GPMCFCLKDIVIDER > 0.
GPMC_CONFIG1_i Register: GPMCFCLKDIVIDER = 1h to 3h:
- GPMC0_CLK frequency = GPMC_FCLK frequency / (2 to 4)

GPMC/NOR Flash Switching Characteristics - Synchronous Mode 100MHz

(18) (19)

NO.	PARAMETER	DESCRIPTION	MODE	MIN	MAX	UNIT
F0	t _c (clk)	Clock period, GPMC0_CLK, GPMC0_FCLK_MUX		10 ⁽²⁰⁾		ns
F1	t _w (clk)	Typical pulse duration, GPMC0_CLK high or low		0.475P ⁽¹⁶⁾ - 0.3 ⁽²⁰⁾		ns

(18) (19)

NO.	PARAMETER	DESCRIPTION	MODE	MIN	MAX	UNIT
F2	$t_{d(\text{clkH-csnV})}$	Delay time, GPMC0_CLK rising edge to GPMC0_CS $n[x]^{(15)}$ transition		F ⁽⁶⁾ - 2.2 ⁽²⁰⁾	F ⁽⁶⁾ +3.75	ns
F3	$t_{d(\text{clkH-csnIV})}$	Delay time, GPMC0_CLK rising edge to GPMC0_CS $n[x]^{(15)}$ invalid		E ⁽⁵⁾ - 2.2	E ⁽⁵⁾ +3.18	ns
F4	$t_{d(\text{aV-clk})}$	Delay time, GPMC0_A[27:1] valid to GPMC0_CLK first edge		B ⁽²⁾ - 2.3 ⁽²⁰⁾	B ⁽²⁾ + 4.5	ns
F5	$t_{d(\text{clkH-aIV})}$	Delay time, GPMC0_CLK rising edge to GPMC0_A[27:1] invalid		- 2.3 ⁽²⁰⁾	4.5	ns
F6	$t_{d(\text{be}[x]nV-clk)}$	Delay time, GPMC0_BE0 n_{CLE} , GPMC0_BE1 n valid to GPMC0_CLK first edge		B ⁽²⁾ - 2.3 ⁽²⁰⁾	B ⁽²⁾ + 1.9	ns
F7	$t_{d(\text{clkH-be}[x]nIV)}$	Delay time, GPMC0_CLK rising edge to GPMC0_BE0 n_{CLE} , GPMC0_BE1 n invalid ⁽¹²⁾		D ⁽⁴⁾ - 2.3 ⁽²⁰⁾	D ⁽⁴⁾ + 1.9	ns
F7	$t_{d(\text{clkL-be}[x]nIV)}$	Delay time, GPMC0_CLK falling edge to GPMC0_BE0 n_{CLE} , GPMC0_BE1 n invalid ⁽¹³⁾		D ⁽⁴⁾ - 2.3 ⁽²⁰⁾	D ⁽⁴⁾ + 1.9	ns
F7	$t_{d(\text{clkL-be}[x]nIV)}$	Delay time, GPMC0_CLK falling edge to GPMC0_BE0 n_{CLE} , GPMC0_BE1 n invalid ⁽¹⁴⁾		D ⁽⁴⁾ - 2.3 ⁽²⁰⁾	D ⁽⁴⁾ + 1.9	ns
F8	$t_{d(\text{clkH-advn})}$	Delay time, GPMC0_CLK rising edge to GPMC0_ADV n_{ALE} transition		G ⁽⁷⁾ (8) - 2.3 ⁽²⁰⁾	G ⁽⁷⁾ (8) + 4.5	ns
F9	$t_{d(\text{clkH-advnIV})}$	Delay time, GPMC0_CLK rising edge to GPMC0_ADV n_{ALE} invalid		D ⁽⁴⁾ - 2.3 ⁽²⁰⁾	D ⁽⁴⁾ + 4.5	ns
F10	$t_{d(\text{clkH-oen})}$	Delay time, GPMC0_CLK rising edge to GPMC0_OE n_{REn} transition		H ⁽⁹⁾ - 2.3 ⁽²⁰⁾	H ⁽⁹⁾ + 3.5	ns
F11	$t_{d(\text{clkH-oenIV})}$	Delay time, GPMC0_CLK rising edge to GPMC0_OE n_{REn} invalid		H ⁽⁹⁾ - 2.3 ⁽²⁰⁾	H ⁽⁹⁾ + 3.5	ns
F14	$t_{d(\text{clkH-wen})}$	Delay time, GPMC0_CLK rising edge to GPMC0_WEn transition		I ⁽¹⁰⁾ - 2.3 ⁽²⁰⁾	I ⁽¹⁰⁾ + 4.5	ns
F15	$t_{d(\text{clkH-do})}$	Delay time, GPMC0_CLK rising edge to GPMC0_AD[31:0] transition ⁽¹²⁾		J ⁽¹¹⁾ - 2.3 ⁽²⁰⁾	J ⁽¹¹⁾ + 2.7	ns
F15	$t_{d(\text{clkL-do})}$	Delay time, GPMC0_CLK falling edge to GPMC0_AD[31:0] data bus transition ⁽¹³⁾		J ⁽¹¹⁾ - 2.3 ⁽²⁰⁾	J ⁽¹¹⁾ + 2.7	ns
F15	$t_{d(\text{clkL-do})}$	Delay time, GPMC0_CLK falling edge to GPMC0_AD[31:0] data bus transition ⁽¹⁴⁾		J ⁽¹¹⁾ - 2.3 ⁽²⁰⁾	J ⁽¹¹⁾ + 2.7	ns
F17	$t_{d(\text{clkH-be}[x]n)}$	Delay time, GPMC0_CLK rising edge to GPMC0_BE0 n_{CLE} transition ⁽¹²⁾		J ⁽¹¹⁾ - 2.3 ⁽²⁰⁾	J ⁽¹¹⁾ + 1.9	ns
F17	$t_{d(\text{clkL-be}[x]n)}$	Delay time, GPMC0_CLK falling edge to GPMC0_BE0 n_{CLE} , GPMC0_BE1 n transition ⁽¹³⁾		J ⁽¹¹⁾ - 2.3 ⁽²⁰⁾	J ⁽¹¹⁾ + 1.9	ns
F17	$t_{d(\text{clkL-be}[x]n)}$	Delay time, GPMC0_CLK falling edge to GPMC0_BE0 n_{CLE} , GPMC0_BE1 n transition ⁽¹⁴⁾		J ⁽¹¹⁾ - 2.3 ⁽²⁰⁾	J ⁽¹¹⁾ + 1.9	ns
F18	$t_{w(\text{csnV})}$	Pulse duration, GPMC0_CS $n[x]^{(15)}$ low	Read	A ⁽¹⁾		ns
			Write	A ⁽¹⁾		ns
F19	$t_{w(\text{be}[x]nV)}$	Pulse duration, GPMC0_BE0 n_{CLE} , GPMC0_BE1 n low	Read	C ⁽³⁾		ns
			Write	C ⁽³⁾		ns
F20	$t_{w(\text{advnV})}$	Pulse duration, GPMC0_ADV n_{ALE} low	Read	K ⁽¹⁷⁾		ns
			Write	K ⁽¹⁷⁾		ns

- (1) For single read: $A = (\text{CSRdOffTime} - \text{CSOnTime}) \times (\text{TimeParaGranularity} + 1) \times \text{GPMC_FCLK}(17)$
 For burst read: $A = (\text{CSRdOffTime} - \text{CSOnTime} + (n - 1) \times \text{PageBurstAccessTime}) \times (\text{TimeParaGranularity} + 1) \times \text{GPMC_FCLK}(17)$
 For burst write: $A = (\text{CSWrOffTime} - \text{CSOnTime} + (n - 1) \times \text{PageBurstAccessTime}) \times (\text{TimeParaGranularity} + 1) \times \text{GPMC_FCLK}(17)$
 With n being the page burst access number.

- (2) $B = \text{ClkActivationTime} \times \text{GPMC_FCLK}(17)$
- (3) For single read: $C = \text{RdCycleTime} \times (\text{TimeParaGranularity} + 1) \times \text{GPMC_FCLK}(17)$
For burst read: $C = (\text{RdCycleTime} + (n - 1) \times \text{PageBurstAccessTime}) \times (\text{TimeParaGranularity} + 1) \times \text{GPMC_FCLK}(17)$
For burst write: $C = (\text{WrCycleTime} + (n - 1) \times \text{PageBurstAccessTime}) \times (\text{TimeParaGranularity} + 1) \times \text{GPMC_FCLK}(17)$
With n being the page burst access number.
- (4) For single read: $D = (\text{RdCycleTime} - \text{AccessTime}) \times (\text{TimeParaGranularity} + 1) \times \text{GPMC_FCLK}(17)$
For burst read: $D = (\text{RdCycleTime} - \text{AccessTime}) \times (\text{TimeParaGranularity} + 1) \times \text{GPMC_FCLK}(17)$
For burst write: $D = (\text{WrCycleTime} - \text{AccessTime}) \times (\text{TimeParaGranularity} + 1) \times \text{GPMC_FCLK}(17)$
- (5) For single read: $E = (\text{CSRdOffTime} - \text{AccessTime}) \times (\text{TimeParaGranularity} + 1) \times \text{GPMC_FCLK}(17)$
For burst read: $E = (\text{CSRdOffTime} - \text{AccessTime}) \times (\text{TimeParaGranularity} + 1) \times \text{GPMC_FCLK}(17)$
For burst write: $E = (\text{CSWrOffTime} - \text{AccessTime}) \times (\text{TimeParaGranularity} + 1) \times \text{GPMC_FCLK}(17)$
- (6) For csn falling edge (CS activated):
 - Case GpmcFCLKDivider = 0:
 - $F = 0.5 \times \text{CSExtraDelay} \times \text{GPMC_FCLK}(17)$
 - Case GpmcFCLKDivider = 1:
 - $F = 0.5 \times \text{CSExtraDelay} \times \text{GPMC_FCLK}(17)$ if (ClkActivationTime and CSOnTime are odd) or (ClkActivationTime and CSOnTime are even)
 - $F = (1 + 0.5 \times \text{CSExtraDelay}) \times \text{GPMC_FCLK}(17)$ otherwise
 - Case GpmcFCLKDivider = 2:
 - $F = 0.5 \times \text{CSExtraDelay} \times \text{GPMC_FCLK}(17)$ if ((CSOnTime - ClkActivationTime) is a multiple of 3)
 - $F = (1 + 0.5 \times \text{CSExtraDelay}) \times \text{GPMC_FCLK}(17)$ if ((CSOnTime - ClkActivationTime - 1) is a multiple of 3)
 - $F = (2 + 0.5 \times \text{CSExtraDelay}) \times \text{GPMC_FCLK}(17)$ if ((CSOnTime - ClkActivationTime - 2) is a multiple of 3)
- (7) For ADV falling edge (ADV activated):
 - Case GpmcFCLKDivider = 0:
 - $G = 0.5 \times \text{ADVExtraDelay} \times \text{GPMC_FCLK}(17)$
 - Case GpmcFCLKDivider = 1:
 - $G = 0.5 \times \text{ADVExtraDelay} \times \text{GPMC_FCLK}(17)$ if (ClkActivationTime and ADVOnTime are odd) or (ClkActivationTime and ADVOnTime are even)
 - $G = (1 + 0.5 \times \text{ADVExtraDelay}) \times \text{GPMC_FCLK}(17)$ otherwise
 - Case GpmcFCLKDivider = 2:
 - $G = 0.5 \times \text{ADVExtraDelay} \times \text{GPMC_FCLK}(17)$ if ((ADVOnTime - ClkActivationTime) is a multiple of 3)
 - $G = (1 + 0.5 \times \text{ADVExtraDelay}) \times \text{GPMC_FCLK}(17)$ if ((ADVOnTime - ClkActivationTime - 1) is a multiple of 3)
 - $G = (2 + 0.5 \times \text{ADVExtraDelay}) \times \text{GPMC_FCLK}(17)$ if ((ADVOnTime - ClkActivationTime - 2) is a multiple of 3)

For ADV rising edge (ADV deactivated) in Reading mode:

 - Case GpmcFCLKDivider = 0:
 - $G = 0.5 \times \text{ADVExtraDelay} \times \text{GPMC_FCLK}(17)$
 - Case GpmcFCLKDivider = 1:
 - $G = 0.5 \times \text{ADVExtraDelay} \times \text{GPMC_FCLK}(17)$ if (ClkActivationTime and ADVRdOffTime are odd) or (ClkActivationTime and ADVRdOffTime are even)
 - $G = (1 + 0.5 \times \text{ADVExtraDelay}) \times \text{GPMC_FCLK}(17)$ otherwise
 - Case GpmcFCLKDivider = 2:
 - $G = 0.5 \times \text{ADVExtraDelay} \times \text{GPMC_FCLK}(17)$ if ((ADVRdOffTime - ClkActivationTime) is a multiple of 3)
 - $G = (1 + 0.5 \times \text{ADVExtraDelay}) \times \text{GPMC_FCLK}(17)$ if ((ADVRdOffTime - ClkActivationTime - 1) is a multiple of 3)
 - $G = (2 + 0.5 \times \text{ADVExtraDelay}) \times \text{GPMC_FCLK}(17)$ if ((ADVRdOffTime - ClkActivationTime - 2) is a multiple of 3)
- (8) For ADV rising edge (ADV deactivated) in Writing mode:
 - Case GpmcFCLKDivider = 0:
 - $G = 0.5 \times \text{ADVExtraDelay} \times \text{GPMC_FCLK}(17)$
 - Case GpmcFCLKDivider = 1:
 - $G = 0.5 \times \text{ADVExtraDelay} \times \text{GPMC_FCLK}(17)$ if (ClkActivationTime and ADVWrOffTime are odd) or (ClkActivationTime and ADVWrOffTime are even)
 - $G = (1 + 0.5 \times \text{ADVExtraDelay}) \times \text{GPMC_FCLK}(17)$ otherwise
 - Case GpmcFCLKDivider = 2:
 - $G = 0.5 \times \text{ADVExtraDelay} \times \text{GPMC_FCLK}(17)$ if ((ADVWrOffTime - ClkActivationTime) is a multiple of 3)
 - $G = (1 + 0.5 \times \text{ADVExtraDelay}) \times \text{GPMC_FCLK}(17)$ if ((ADVWrOffTime - ClkActivationTime - 1) is a multiple of 3)
 - $G = (2 + 0.5 \times \text{ADVExtraDelay}) \times \text{GPMC_FCLK}(17)$ if ((ADVWrOffTime - ClkActivationTime - 2) is a multiple of 3)
- (9) For OE falling edge (OE activated) and IO DIR rising edge (Data Bus input direction):
 - Case GpmcFCLKDivider = 0:
 - $H = 0.5 \times \text{OEEExtraDelay} \times \text{GPMC_FCLK}(17)$
 - Case GpmcFCLKDivider = 1:
 - $H = 0.5 \times \text{OEEExtraDelay} \times \text{GPMC_FCLK}(17)$ if (ClkActivationTime and OEOnTime are odd) or (ClkActivationTime and OEOnTime are even)
 - $H = (1 + 0.5 \times \text{OEEExtraDelay}) \times \text{GPMC_FCLK}(17)$ otherwise
 - Case GpmcFCLKDivider = 2:
 - $H = 0.5 \times \text{OEEExtraDelay} \times \text{GPMC_FCLK}(17)$ if ((OEOnTime - ClkActivationTime) is a multiple of 3)
 - $H = (1 + 0.5 \times \text{OEEExtraDelay}) \times \text{GPMC_FCLK}(17)$ if ((OEOnTime - ClkActivationTime - 1) is a multiple of 3)

- $H = (2 + 0.5 \times \text{OEEExtraDelay}) \times \text{GPMC_FCLK}(17)$ if $((\text{OEOnTime} - \text{ClkActivationTime} - 2)$ is a multiple of 3)
- For OE rising edge (OE deactivated):
- Case $\text{GpmcFCLKDivider} = 0$:
 - $H = 0.5 \times \text{OEEExtraDelay} \times \text{GPMC_FCLK}(17)$
 - Case $\text{GpmcFCLKDivider} = 1$:
 - $H = 0.5 \times \text{OEEExtraDelay} \times \text{GPMC_FCLK}(17)$ if $(\text{ClkActivationTime}$ and OEOffTime are odd) or $(\text{ClkActivationTime}$ and OEOffTime are even)
 - $H = (1 + 0.5 \times \text{OEEExtraDelay}) \times \text{GPMC_FCLK}(17)$ otherwise
 - Case $\text{GpmcFCLKDivider} = 2$:
 - $H = 0.5 \times \text{OEEExtraDelay} \times \text{GPMC_FCLK}(17)$ if $((\text{OEOffTime} - \text{ClkActivationTime})$ is a multiple of 3)
 - $H = (1 + 0.5 \times \text{OEEExtraDelay}) \times \text{GPMC_FCLK}(17)$ if $((\text{OEOffTime} - \text{ClkActivationTime} - 1)$ is a multiple of 3)
 - $H = (2 + 0.5 \times \text{OEEExtraDelay}) \times \text{GPMC_FCLK}(17)$ if $((\text{OEOffTime} - \text{ClkActivationTime} - 2)$ is a multiple of 3)
- (10) For WE falling edge (WE activated):
- Case $\text{GpmcFCLKDivider} = 0$:
 - $I = 0.5 \times \text{WEEExtraDelay} \times \text{GPMC_FCLK}(17)$
 - Case $\text{GpmcFCLKDivider} = 1$:
 - $I = 0.5 \times \text{WEEExtraDelay} \times \text{GPMC_FCLK}(17)$ if $(\text{ClkActivationTime}$ and WEOnTime are odd) or $(\text{ClkActivationTime}$ and WEOnTime are even)
 - $I = (1 + 0.5 \times \text{WEEExtraDelay}) \times \text{GPMC_FCLK}(17)$ otherwise
 - Case $\text{GpmcFCLKDivider} = 2$:
 - $I = 0.5 \times \text{WEEExtraDelay} \times \text{GPMC_FCLK}(17)$ if $((\text{WEOnTime} - \text{ClkActivationTime})$ is a multiple of 3)
 - $I = (1 + 0.5 \times \text{WEEExtraDelay}) \times \text{GPMC_FCLK}(17)$ if $((\text{WEOnTime} - \text{ClkActivationTime} - 1)$ is a multiple of 3)
 - $I = (2 + 0.5 \times \text{WEEExtraDelay}) \times \text{GPMC_FCLK}(17)$ if $((\text{WEOnTime} - \text{ClkActivationTime} - 2)$ is a multiple of 3)
- For WE rising edge (WE deactivated):
- Case $\text{GpmcFCLKDivider} = 0$:
 - $I = 0.5 \times \text{WEEExtraDelay} \times \text{GPMC_FCLK}(17)$
 - Case $\text{GpmcFCLKDivider} = 1$:
 - $I = 0.5 \times \text{WEEExtraDelay} \times \text{GPMC_FCLK}(17)$ if $(\text{ClkActivationTime}$ and WEOffTime are odd) or $(\text{ClkActivationTime}$ and WEOffTime are even)
 - $I = (1 + 0.5 \times \text{WEEExtraDelay}) \times \text{GPMC_FCLK}(17)$ otherwise
 - Case $\text{GpmcFCLKDivider} = 2$:
 - $I = 0.5 \times \text{WEEExtraDelay} \times \text{GPMC_FCLK}(17)$ if $((\text{WEOffTime} - \text{ClkActivationTime})$ is a multiple of 3)
 - $I = (1 + 0.5 \times \text{WEEExtraDelay}) \times \text{GPMC_FCLK}(17)$ if $((\text{WEOffTime} - \text{ClkActivationTime} - 1)$ is a multiple of 3)
 - $I = (2 + 0.5 \times \text{WEEExtraDelay}) \times \text{GPMC_FCLK}(17)$ if $((\text{WEOffTime} - \text{ClkActivationTime} - 2)$ is a multiple of 3)
- (11) $J = \text{GPMC_FCLK}(17)$
- (12) First transfer only for CLK DIV 1 mode.
- (13) Half cycle; for all data after initial transfer for CLK DIV 1 mode.
- (14) Half cycle of GPMC_CLK_OUT ; for all data for modes other than CLK DIV 1 mode. GPMC_CLK_OUT divide down from GPMC_FCLK .
- (15) In $\text{GPMC_CSn}[x]$, x is equal to 0, 1, 2 or 3. In $\text{GPMC_WAIT}[x]$, x is equal to 0 or 1.
- (16) $P = \text{GPMC_CLK}$ period in ns
- (17) For read: $K = (\text{ADVrOffTime} - \text{ADVOnTime}) \times (\text{TimeParaGranularity} + 1) \times \text{GPMC_FCLK}(17)$
For write: $K = (\text{ADVwOffTime} - \text{ADVOnTime}) \times (\text{TimeParaGranularity} + 1) \times \text{GPMC_FCLK}(17)$
- (18) GPMC_FCLK is general-purpose memory controller internal functional clock period in ns.
- (19) 100MHz GPMC_FCLK selected - $\text{CTRLMMR_GPMC_CLKSEL}[0]$ $\text{CLK_SEL} = 1 = \text{MAIN_PLL2_HSDIV7_CLKOUT}$ (100/60 MHz)
- (20) In div_by_1_mode , GPMC0_CLK refers to either GPMC0_CLKOUT or GPMC0_FCLK_MUX (free-running). Both signals are pin-muxed to the same pin
- GPMC_CONFIG1_i Register: $\text{GPMCFCLKDIVIDER} = 0\text{h}$:
 - GPMC0_CLK frequency = GPMC_FCLK frequency
- In not_div_by_1_mode , GPMC0_CLK only refers to GPMC0_CLKOUT . GPMC0_FCLK_MUX cannot be clock divided to match the GPMC0_CLKOUT frequency if $\text{GPMCFCLKDIVIDER} > 0$
- GPMC_CONFIG1_i Register: $\text{GPMCFCLKDIVIDER} = 1\text{h}$ to 3h :
 - GPMC0_CLK frequency = GPMC_FCLK frequency / (2 to 4)

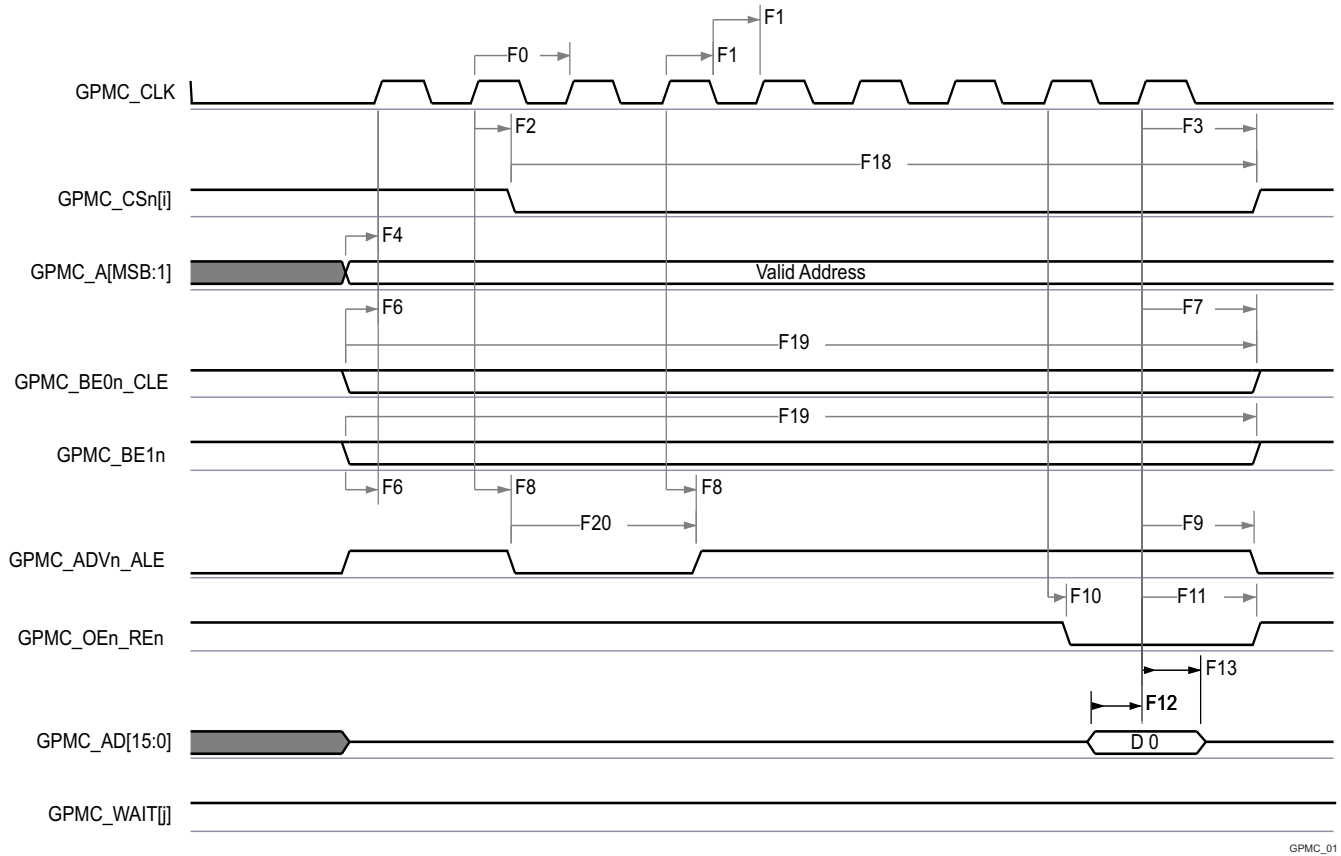

GPMC_01

- A. In GPMC_CS[n][i], i is equal to 0, 1, 2 or 3.
- B. In GPMC_WAIT[j], j is equal to 0 or 1.

图 7-18. GPMC and NOR Flash — Synchronous Single Read (GPMCFCLKDIVIDER = 0)

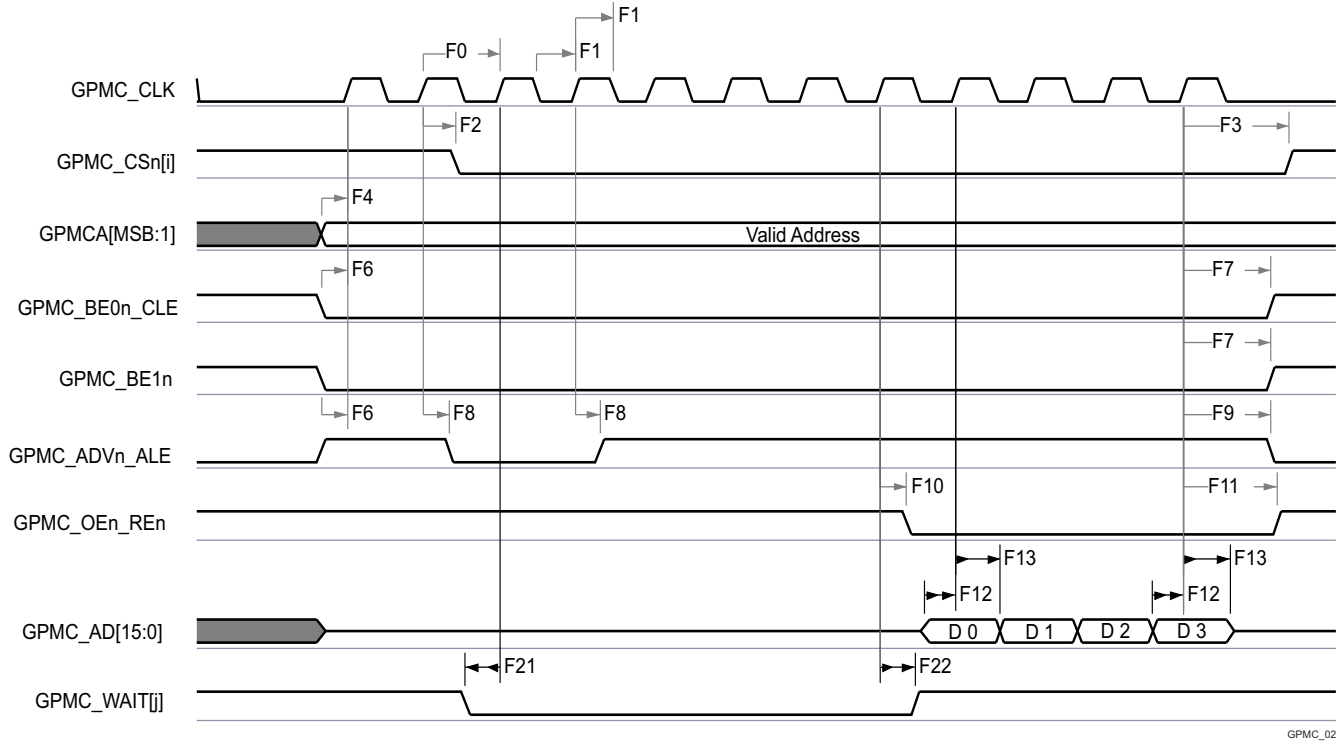

GPMC_02

- A. In GPMC_CS[n][i], i is equal to 0, 1, 2 or 3.
- B. In GPMC_WAIT[j], j is equal to 0 or 1.

图 7-19. GPMC and NOR Flash — Synchronous Burst Read — 4x16 - bit (GPMCFCLKDIVIDER = 0)

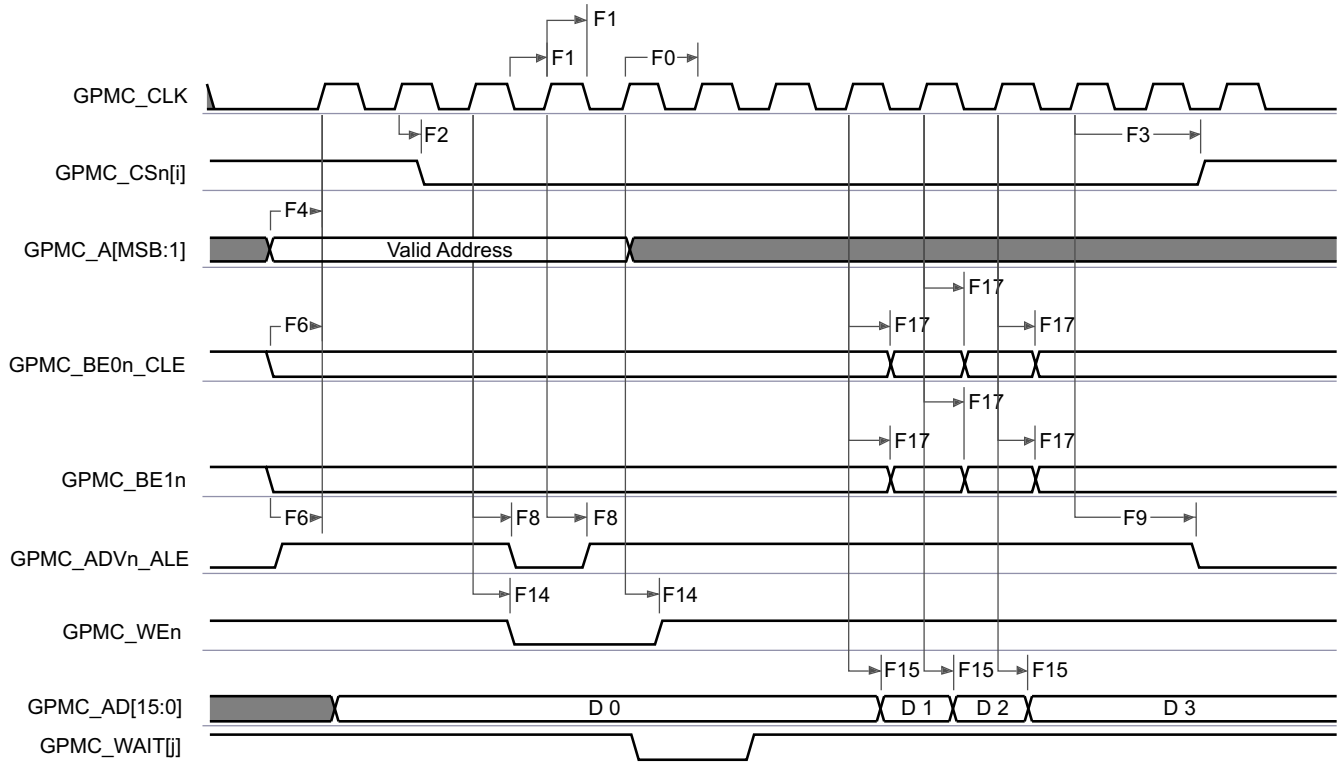

GPMC_03

- A. In GPMC_CS[n][i], i is equal to 0, 1, 2 or 3.

B. In GPMC_WAIT[j], j is equal to 0 or 1.

图 7-20. GPMC and NOR Flash—Synchronous Burst Write (GPMCFCLKDIVIDER = 0)

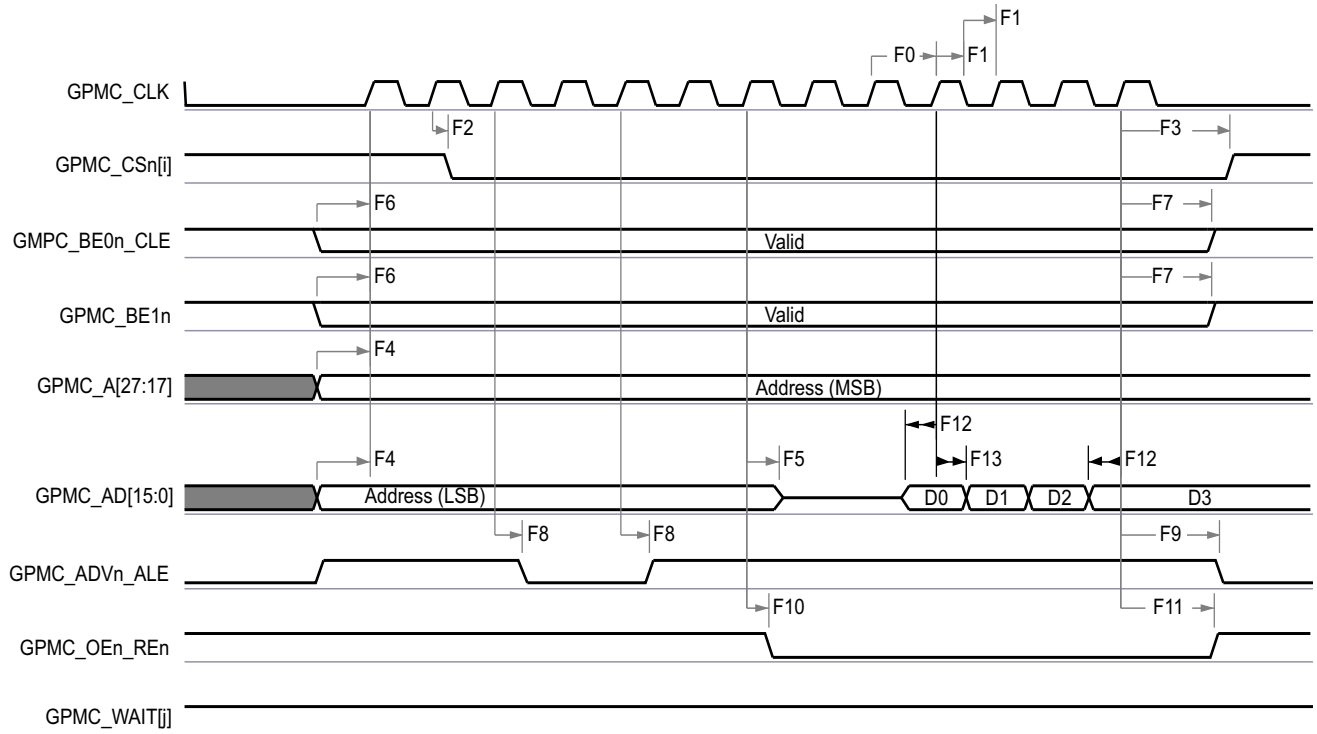

GPMC_04

A. In GPMC_CS[n][i], i is equal to 0, 1, 2 or 3.

B. In GPMC_WAIT[j], j is equal to 0 or 1.

图 7-21. GPMC and Multiplexed NOR Flash — Synchronous Burst Read

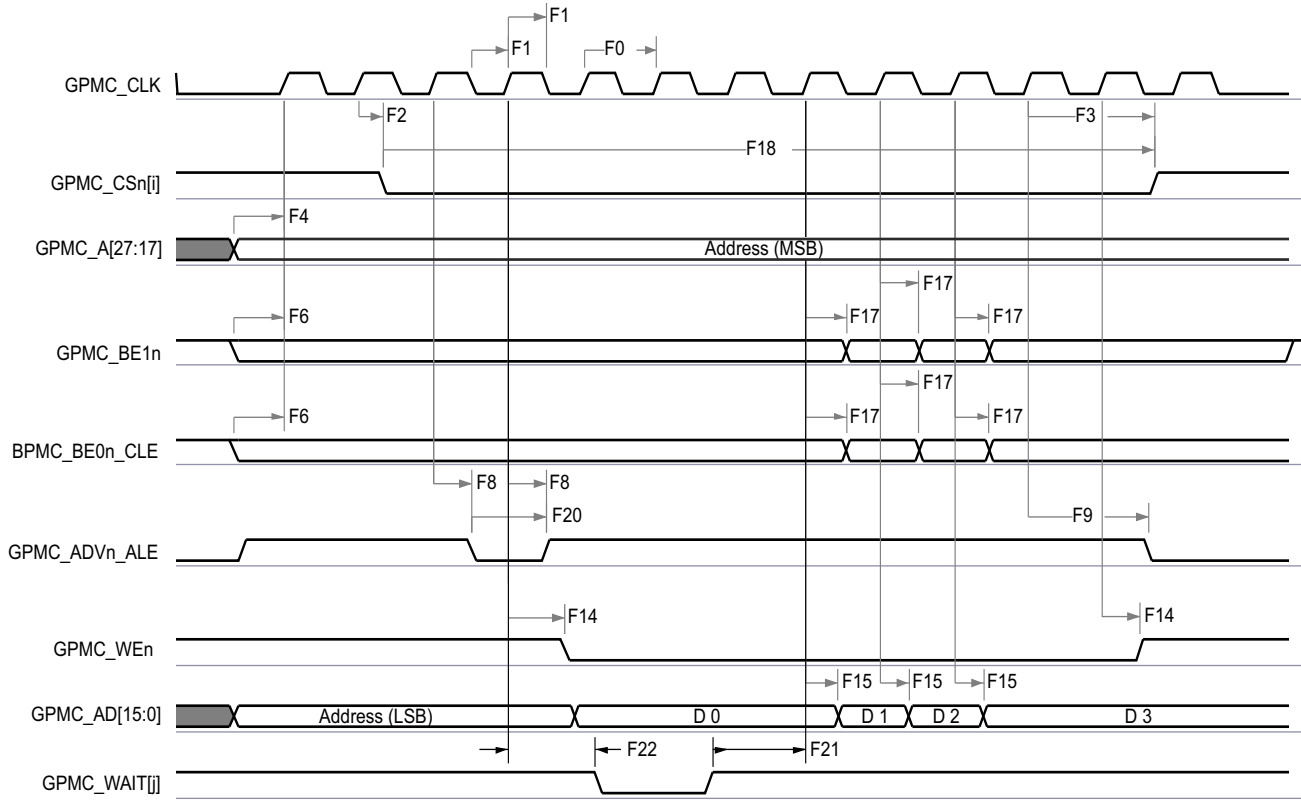

GPMC_05

- A. In GPMC_CS[n][i], i is equal to 0, 1, 2 or 3.
- B. In GPMC_WAIT[j], j is equal to 0 or 1.

图 7-22. GPMC and Multiplexed NOR Flash — Synchronous Burst Write

GPMC/NOR Flash Timing Requirements - Asynchronous Mode 100MHz
(6)

NO.	PARAMETER	DESCRIPTION	MIN	MAX	UNIT
FA5 ⁽¹⁾	t _{acc(d)}	Data access time		H ⁽⁵⁾	ns
FA20 ⁽²⁾	t _{acc1-pgmode(d)}	Page mode successive data access time		P ⁽⁴⁾	ns
FA21 ⁽³⁾	t _{acc2-pgmode(d)}	Page mode first data access time		H ⁽⁵⁾	ns

- (1) The FA5 parameter illustrates the amount of time required to internally sample input data. It is expressed in number of GPMC functional clock cycles. From start of read cycle and after FA5 functional clock cycles, input data is internally sampled by active functional clock edge. FA5 value must be stored inside the AccessTime register bit field.
- (2) The FA20 parameter illustrates amount of time required to internally sample successive input page data. It is expressed in number of GPMC functional clock cycles. After each access to input page data, next input page data is internally sampled by active functional clock edge after FA20 functional clock cycles. The FA20 value must be stored in the PageBurstAccessTime register bit field.
- (3) The FA21 parameter illustrates amount of time required to internally sample first input page data. It is expressed in number of GPMC functional clock cycles. From start of read cycle and after FA21 functional clock cycles, first input page data is internally sampled by active functional clock edge. FA21 value must be stored inside the AccessTime register bit field.
- (4) P = PageBurstAccessTime × (TimeParaGranularity + 1) × GPMC_FCLK(6)
- (5) H = AccessTime × (TimeParaGranularity + 1) × GPMC_FCLK(6)
- (6) 133MHz GPMC_FCLK selected - CTRLMMR_GPMC_CLKSEL[0] CLK_SEL = 0 = MAIN_PLL0_HSDIV3_CLKOUT (133/100/80 MHz)

GPMC/NOR Flash Switching Characteristics - Asynchronous Mode 100MHz
(14)

NO.	PARAMETER	DESCRIPTION	MODE	MIN	MAX	UNIT
FA0	t _{w(be[x]nV)}	Pulse duration, GPMC0_BE0n_CLE, GPMC0_BE1n valid time	Read		N ⁽¹²⁾	ns
			Write		N ⁽¹²⁾	ns

(14)

NO.	PARAMETER	DESCRIPTION	MODE	MIN	MAX	UNIT
FA1	$t_{w(csnV)}$	Pulse duration, GPMC0_CS $n[x]^{(13)}$ low	Read		A ⁽¹⁾	ns
			Write		A ⁽¹⁾	ns
FA3	$t_{d(csnV-advnV)}$	Delay time, GPMC0_CS $n[x]^{(13)}$ valid to GPMC0_ADV n_ALE invalid	Read	B ⁽²⁾ - 2	B ⁽²⁾ + 2	ns
			Write	B ⁽²⁾ - 2	B ⁽²⁾ + 2	ns
FA4	$t_{d(csnV-oenV)}$	Delay time, GPMC0_CS $n[x]^{(13)}$ valid to GPMC0_OEn_REn invalid (Single read)		C ⁽³⁾ - 2	C ⁽³⁾ + 2	ns
FA9	$t_{d(aV-csnV)}$	Delay time, GPMC0_A[27:1] valid to GPMC0_CS $n[x]^{(13)}$ valid		J ⁽⁹⁾ - 2	J ⁽⁹⁾ + 2	ns
FA10	$t_{d(be[x]nV-csnV)}$	Delay time, GPMC0_BE0n_CLE, GPMC0_BE1n valid to GPMC0_CS $n[x]^{(13)}$ valid		J ⁽⁹⁾ - 2	J ⁽⁹⁾ + 2	ns
FA12	$t_{d(csnV-advnV)}$	Delay time, GPMC0_CS $n[x]^{(13)}$ valid to GPMC0_ADV n_ALE valid		K ⁽¹⁰⁾ - 2	K ⁽¹⁰⁾ + 2	ns
FA13	$t_{d(csnV-oenV)}$	Delay time, GPMC0_CS $n[x]^{(13)}$ valid to GPMC0_OEn_REn valid		L ⁽¹¹⁾ - 2	L ⁽¹¹⁾ + 2	ns
FA16	$t_{w(alV)}$	Pulse durationm GPMC0_A[26:1] invalid between two successive read and write accesses		G ⁽⁷⁾		ns
FA18	$t_{d(csnV-oenV)}$	Delay time, GPMC0_CS $n[x]^{(13)}$ valid to GPMC0_OEn_REn invalid (Burst read)		I ⁽⁸⁾ - 2	I ⁽⁸⁾ + 2	ns
FA20	$t_{w(av)}$	Pulse duration, GPMC0_A[27:1] valid - 2nd, 3rd, and 4th accesses		D ⁽⁴⁾		ns
FA25	$t_{d(csnV-wenV)}$	Delay time, GPMC0_CS $n[x]^{(13)}$ valid to GPMC0_WEn valid		E ⁽⁵⁾ - 2	E ⁽⁵⁾ + 2	ns
FA27	$t_{d(csnV-wenV)}$	Delay time, GPMC0_CS $n[x]^{(13)}$ valid to GPMC0_WEn invalid		F ⁽⁶⁾ - 2	F ⁽⁶⁾ + 2	ns
FA28	$t_{d(wenV-dV)}$	Delay time, GPMC0_WEn valid to GPMC0_AD[31:0] valid			2	ns
FA29	$t_{d(dV-csnV)}$	Delay time, GPMC0_AD[31:0] valid to GPMC0_CS $n[x]^{(13)}$ valid		J ⁽⁹⁾ - 2	J ⁽¹⁰⁾ + 2	ns
FA37	$t_{d(oenV-alV)}$	Delay time, GPMC0_OEn_REn valid to GPMC0_AD[31:0] phase end			2	ns

- (1) For single read: $A = (CSRdOffTime - CSOnTime) \times (TimeParaGranularity + 1) \times GPMC_FCLK(14)$
 For single write: $A = (CSWrOffTime - CSOnTime) \times (TimeParaGranularity + 1) \times GPMC_FCLK(14)$
 For burst read: $A = (CSRdOffTime - CSOnTime + (n - 1) \times PageBurstAccessTime) \times (TimeParaGranularity + 1) \times GPMC_FCLK(14)$
 For burst write: $A = (CSWrOffTime - CSOnTime + (n - 1) \times PageBurstAccessTime) \times (TimeParaGranularity + 1) \times GPMC_FCLK(14)$
 with n being the page burst access number
- (2) For reading: $B = ((ADVRdOffTime - CSOnTime) \times (TimeParaGranularity + 1) + 0.5 \times (ADVExtraDelay - CSEExtraDelay)) \times GPMC_FCLK(14)$
 For writing: $B = ((ADVWrOffTime - CSOnTime) \times (TimeParaGranularity + 1) + 0.5 \times (ADVExtraDelay - CSEExtraDelay)) \times GPMC_FCLK(14)$
- (3) $C = \sqrt{((OEOffTime - CSOnTime) \times (TimeParaGranularity + 1) + 0.5 \times (OEEExtraDelay - CSEExtraDelay))} \times GPMC_FCLK(14)$
- (4) $D = PageBurstAccessTime \times (TimeParaGranularity + 1) \times GPMC_FCLK(14)$
- (5) $E = \sqrt{((WEOOnTime - CSOnTime) \times (TimeParaGranularity + 1) + 0.5 \times (WEEExtraDelay - CSEExtraDelay))} \times GPMC_FCLK(14)$
- (6) $F = \sqrt{((WEOffTime - CSOnTime) \times (TimeParaGranularity + 1) + 0.5 \times (WEEExtraDelay - CSEExtraDelay))} \times GPMC_FCLK(14)$
- (7) $G = Cycle2CycleDelay \times GPMC_FCLK(14)$
- (8) $I = \sqrt{((OEOffTime + (n - 1) \times PageBurstAccessTime - CSOnTime) \times (TimeParaGranularity + 1) + 0.5 \times (OEEExtraDelay - CSEExtraDelay))} \times GPMC_FCLK(14)$
- (9) $J = (CSOnTime \times (TimeParaGranularity + 1) + 0.5 \times CSEExtraDelay) \times GPMC_FCLK(14)$
- (10) $K = \sqrt{((ADVOnTime - CSOnTime) \times (TimeParaGranularity + 1) + 0.5 \times (ADVExtraDelay - CSEExtraDelay))} \times GPMC_FCLK(14)$
- (11) $L = \sqrt{((OEOnTime - CSOnTime) \times (TimeParaGranularity + 1) + 0.5 \times (OEEExtraDelay - CSEExtraDelay))} \times GPMC_FCLK(14)$
- (12) For single read: $N = RdCycleTime \times (TimeParaGranularity + 1) \times GPMC_FCLK(14)$
 For single write: $N = WrCycleTime \times (TimeParaGranularity + 1) \times GPMC_FCLK(14)$
 For burst read: $N = (RdCycleTime + (n - 1) \times PageBurstAccessTime) \times (TimeParaGranularity + 1) \times GPMC_FCLK(14)$
 For burst write: $N = (WrCycleTime + (n - 1) \times PageBurstAccessTime) \times (TimeParaGranularity + 1) \times GPMC_FCLK(14)$
- (13) In GPMC_CS $n[x]$, x is equal to 0, 1, 2 or 3.

(14) 133MHz GPMC_FCLK selected - CTRLMMR_GPMC_CLKSEL[0] CLK_SEL = 0 = MAIN_PLL0_HSDIV3_CLKOUT (133/100/80 MHz)

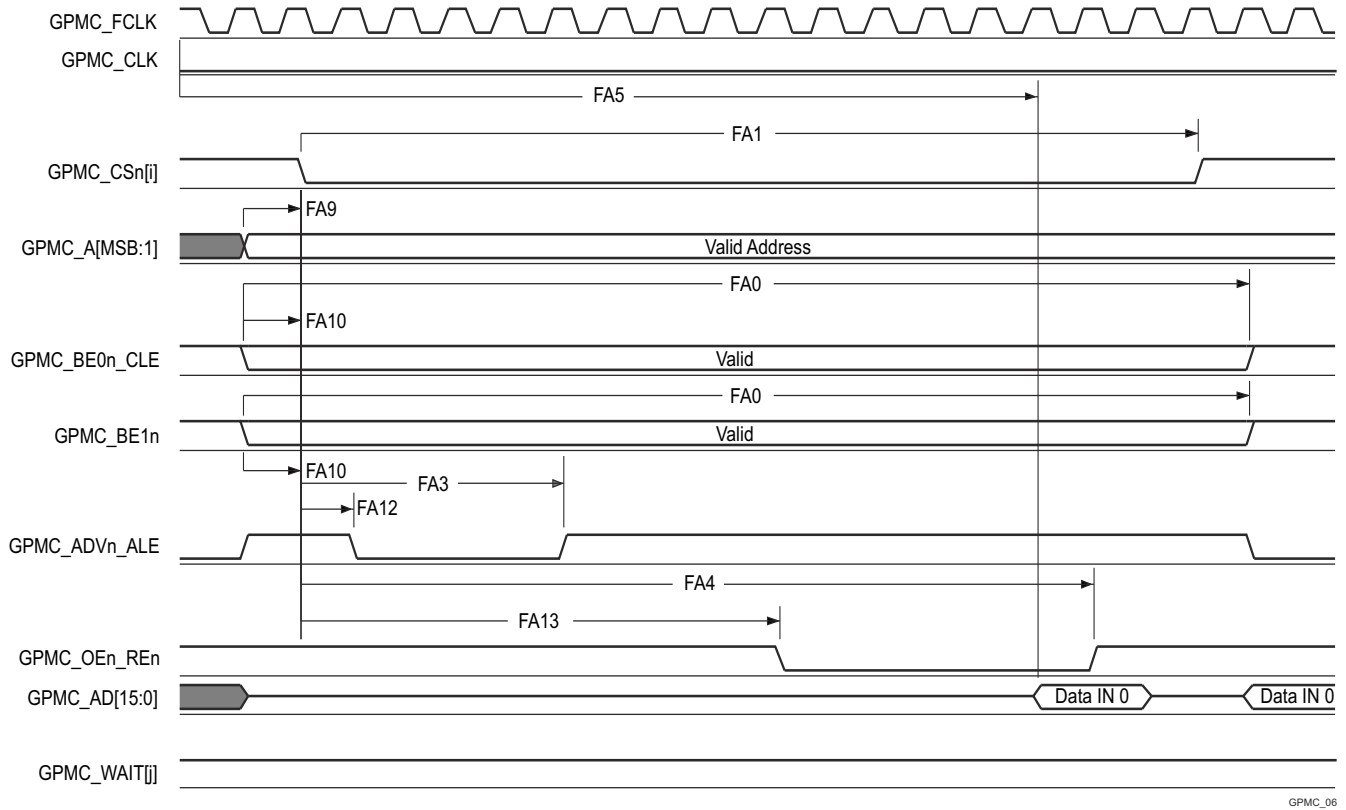

GPMC_06

- A. In GPMC_CS[n][i], i is equal to 0, 1, 2 or 3. In GPMC_WAIT[j], j is equal to 0 or 1.
- B. FA5 parameter illustrates amount of time required to internally sample input data. It is expressed in number of GPMC functional clock cycles. From start of read cycle and after FA5 functional clock cycles, input data will be internally sampled by active functional clock edge. FA5 value must be stored inside AccessTime register bits field.
- C. GPMC_FCLK is an internal clock (GPMC functional clock) not provided externally.

图 7-23. GPMC and NOR Flash — Asynchronous Read — Single Word

ADVANCE INFORMATION

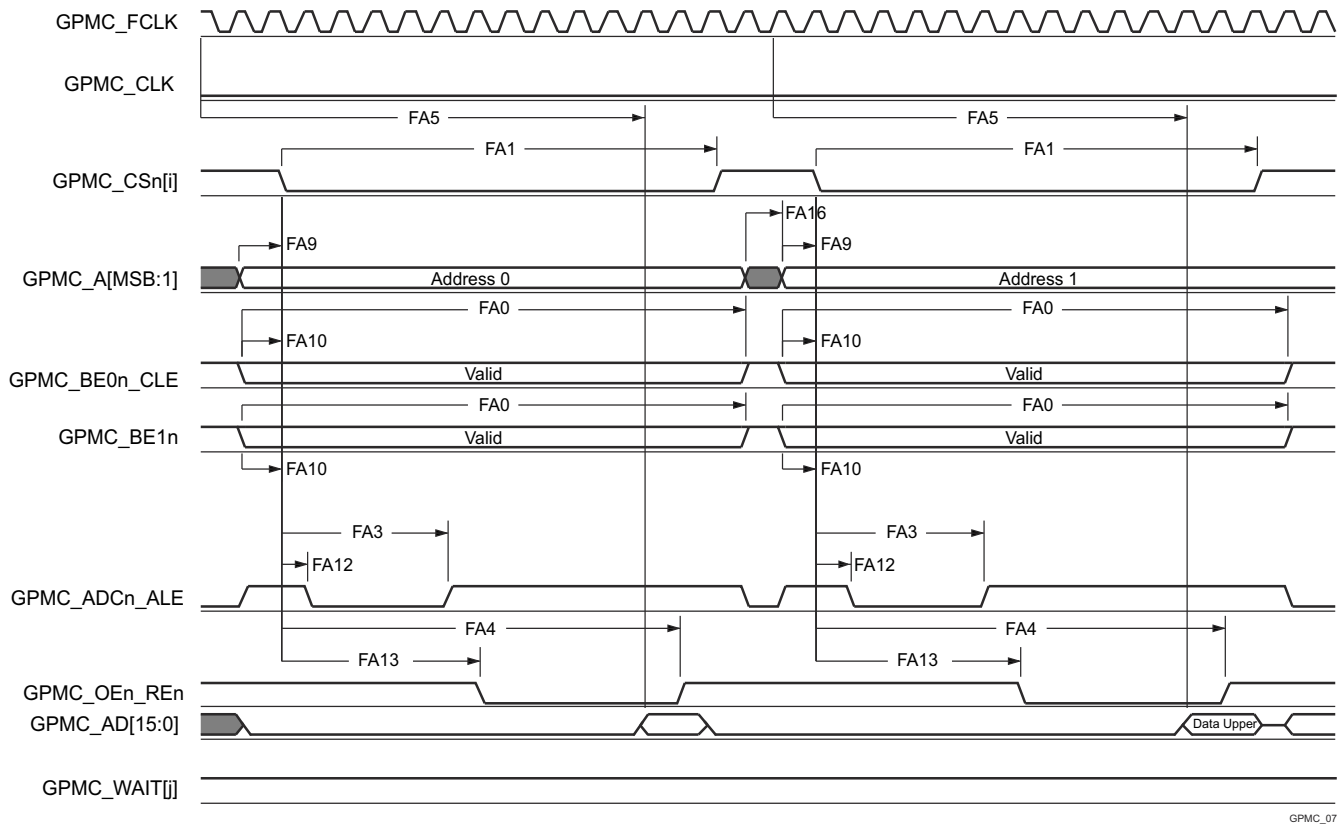

GPMC_07

- A. In GPMC_CS*n*[*i*], *i* is equal to 0, 1, 2 or 3. In GPMC_WAIT[j], *j* is equal to 0 or 1.
- B. FA5 parameter illustrates amount of time required to internally sample input data. It is expressed in number of GPMC functional clock cycles. From start of read cycle and after FA5 functional clock cycles, input data will be internally sampled by active functional clock edge. FA5 value must be stored inside AccessTime register bits field.
- C. GPMC_FCLK is an internal clock (GPMC functional clock) not provided externally.

图 7-24. GPMC and NOR Flash — Asynchronous Read — 32 - Bit

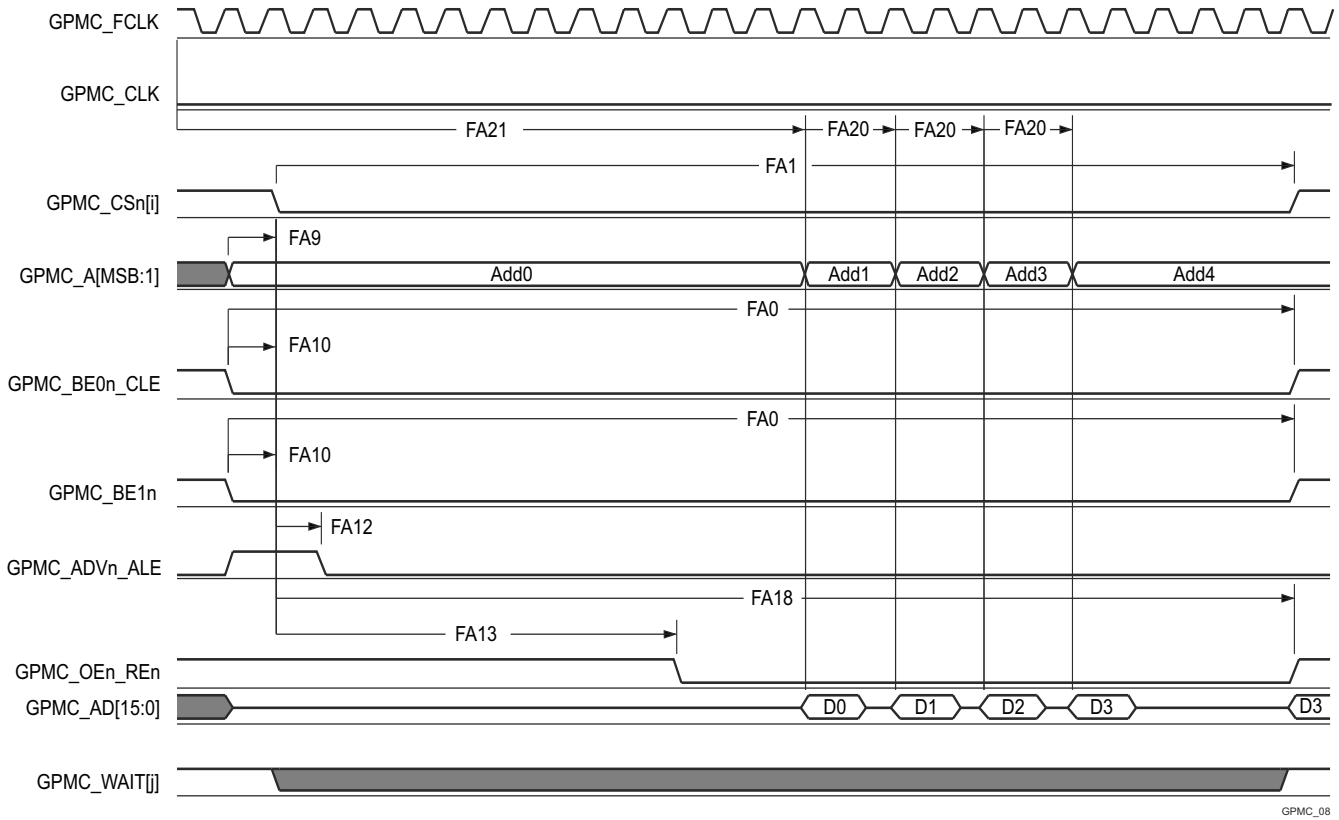

GPMC_08

- A. In GPMC_CS*n*[*i*], *i* is equal to 0, 1, 2 or 3. In GPMC_WAIT[j], *j* is equal to 0 or 1.
- B. FA21 parameter illustrates amount of time required to internally sample first input page data. It is expressed in number of GPMC functional clock cycles. From start of read cycle and after FA21 functional clock cycles, first input page data will be internally sampled by active functional clock edge. FA21 calculation must be stored inside AccessTime register bits field.
- C. FA20 parameter illustrates amount of time required to internally sample successive input page data. It is expressed in number of GPMC functional clock cycles. After each access to input page data, next input page data will be internally sampled by active functional clock edge after FA20 functional clock cycles. FA20 is also the duration of address phases for successive input page data (excluding first input page data). FA20 value must be stored in PageBurstAccessTime register bits field.
- D. GPMC_FCLK is an internal clock (GPMC functional clock) not provided externally.

图 7-25. GPMC and NOR Flash — Asynchronous Read — Page Mode 4x16 - Bit

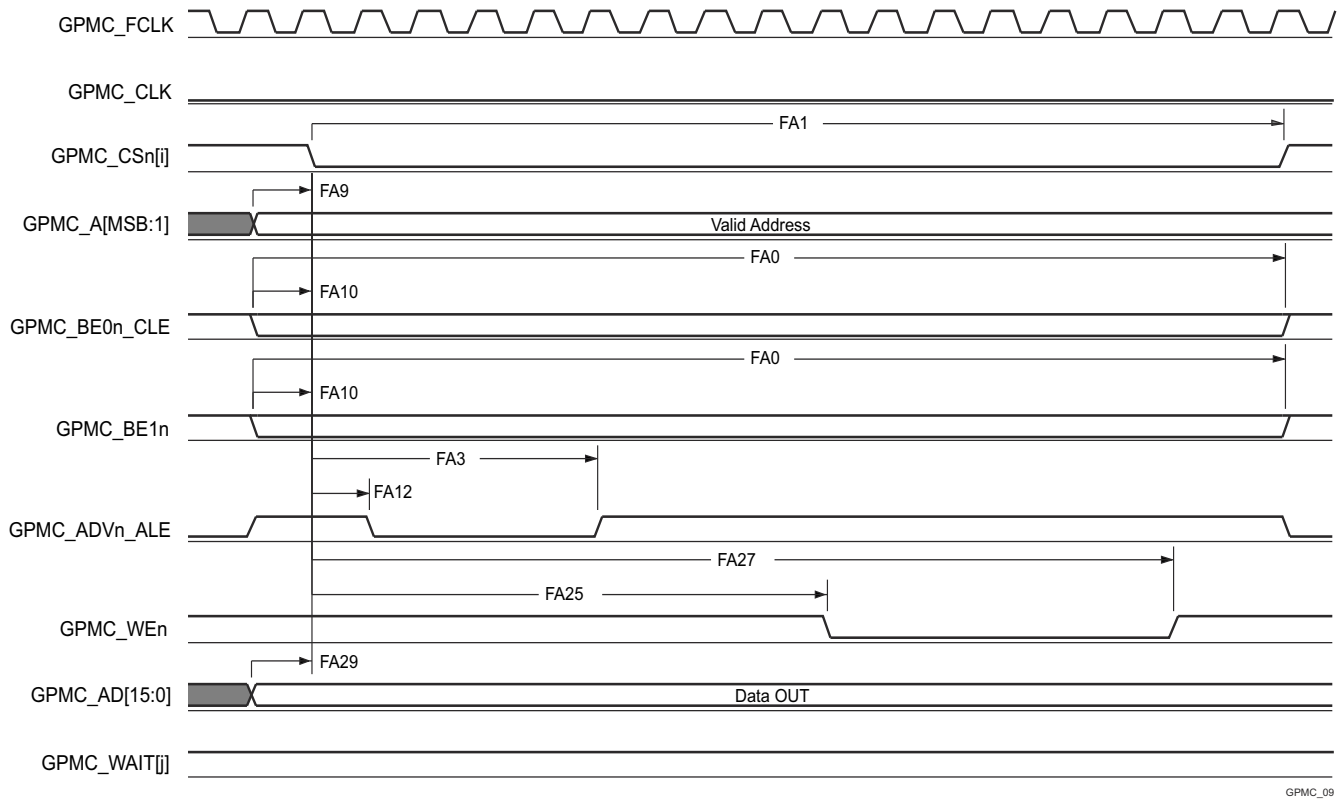

A. In GPMC_CSn[i], i is equal to 0, 1, 2 or 3. In GPMC_WAIT[j], j is equal to 0 or 1.

图 7-26. GPMC and NOR Flash — Asynchronous Write — Single Word

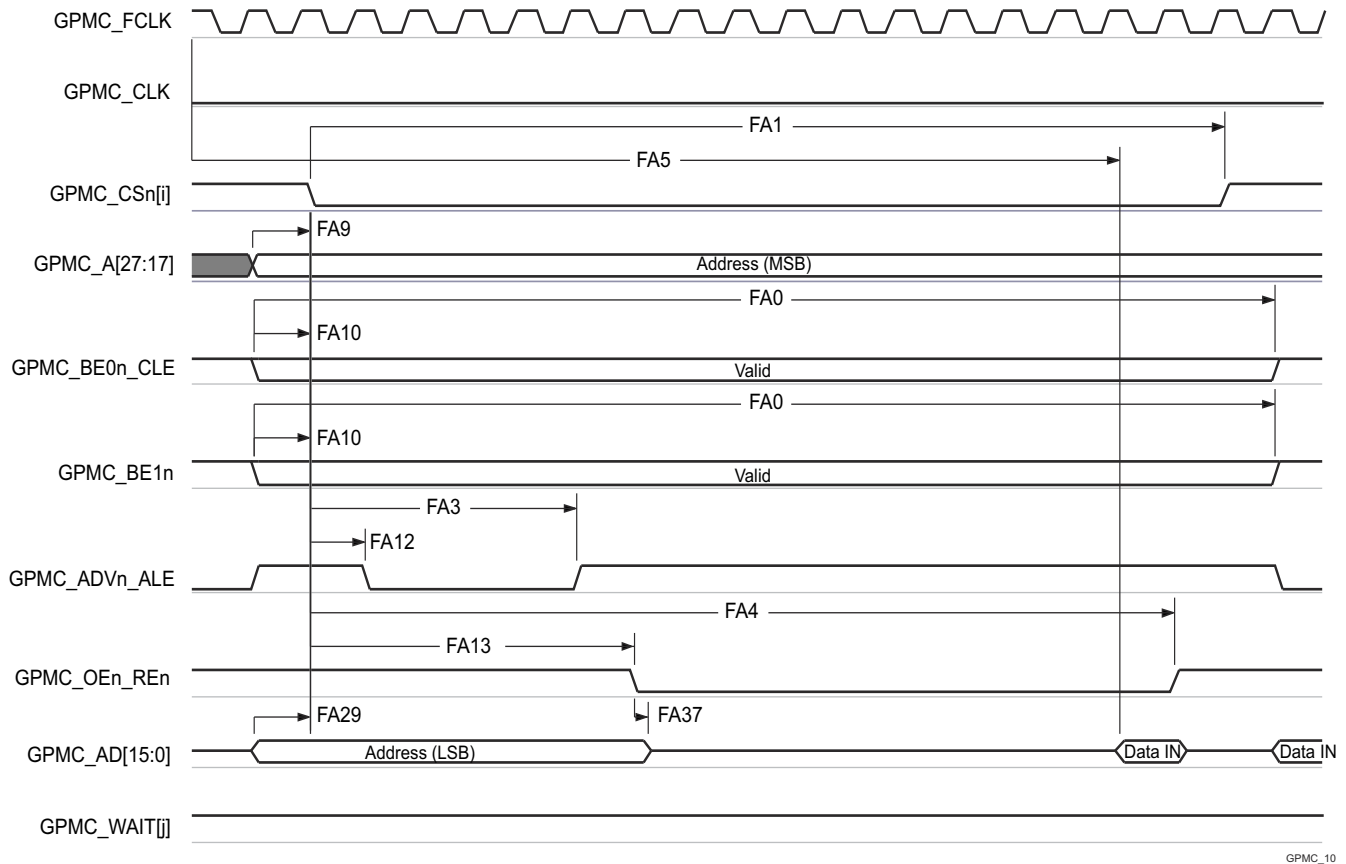

GPMC_10

- A. In GPMC_CS[n][i], i is equal to 0, 1, 2 or 3. In GPMC_WAIT[j], j is equal to 0 or 1.
- B. FA5 parameter illustrates amount of time required to internally sample input data. It is expressed in number of GPMC functional clock cycles. From start of read cycle and after FA5 functional clock cycles, input data will be internally sampled by active functional clock edge. FA5 value must be stored inside AccessTime register bits field.
- C. GPMC_FCLK is an internal clock (GPMC functional clock) not provided externally.

图 7-27. GPMC and Multiplexed NOR Flash — Asynchronous Read — Single Word

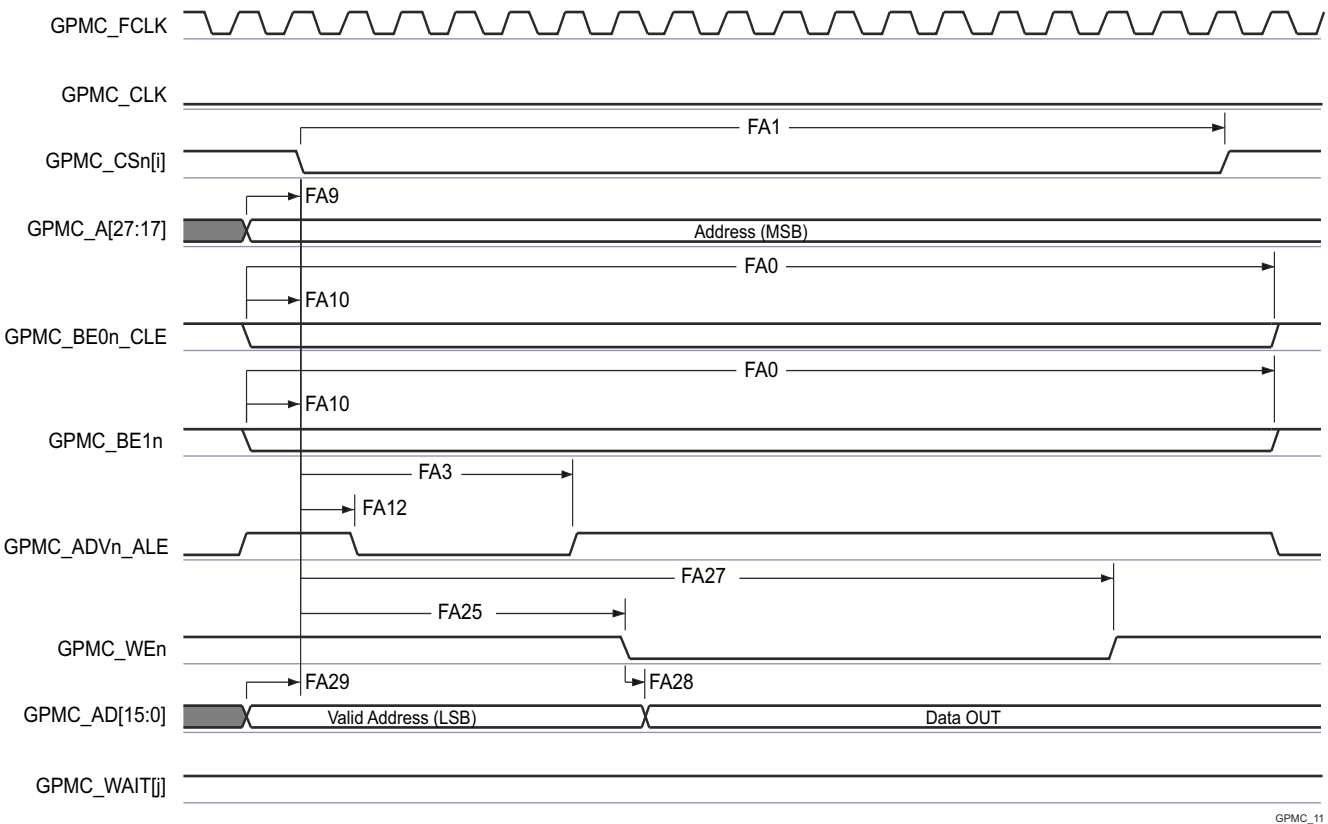

GPMC_11

A. In GPMC_CS*n*[*i*], *i* is equal to 0, 1, 2 or 3. In GPMC_WAIT[j], *j* is equal to 0 or 1.

图 7-28. GPMC and Multiplexed NOR Flash — Asynchronous Write — Single Word

GPMC/NAND Flash Timing Requirements - Asynchronous Mode 100MHz

(4)

NO.	PARAMETER	DESCRIPTION	MIN	MAX	UNIT
GNF12 ⁽¹⁾	$t_{acc(d)}$	Access time, GPMC0_AD[31:0] ⁽³⁾		J ⁽²⁾	ns

- (1) The GNF12 parameter illustrates the amount of time required to internally sample input data. It is expressed in number of GPMC functional clock cycles. From start of the read cycle and after GNF12 functional clock cycles, input data is internally sampled by the active functional clock edge. The GNF12 value must be stored inside AccessTime register bit field.
- (2) $J = \text{AccessTime} \times (\text{TimeParaGranularity} + 1) \times \text{GPMC_FCLK}(3)$
- (3) GPMC_FCLK is general-purpose memory controller internal functional clock.
- (4) 133MHz GPMC_FCLK selected - CTRLMMR_GPMC_CLKSEL[0] CLK_SEL = 0 = MAIN_PLL0_HSDIV3_CLKOUT (133/100/80 MHz)

GPMC/NAND Flash Switching Characteristics - Asynchronous Mode 100MHz

(14)

NO.	PARAMETER	DESCRIPTION	MIN	MAX	UNIT
GNF0	$t_{w(wenV)}$	Pulse duration, GPMC0_WEn valid	A ⁽¹⁾		ns
GNF1	$t_{d(csnV-wenV)}$	Delay time, GPMC0_CS <i>n</i> [<i>x</i>] ⁽¹³⁾ valid to GPMC0_WEn valid	B ⁽²⁾ - 2	B ⁽²⁾ + 2	ns
GNF2	$t_{w(cleH-wenV)}$	Delay time, GPMC0_BE0n_CLE high to GPMC0_WEn valid	C ⁽³⁾ - 2	C ⁽³⁾ + 2	ns
GNF3	$t_{w(wenV-dV)}$	Delay time, GPMC0_AD[31:0] valid to GPMC0_WEn valid	D ⁽⁴⁾ - 2	D ⁽⁴⁾ + 2	ns
GNF4	$t_{w(wenIV-dIV)}$	Delay time, GPMC0_WEn invalid to GPMC0_AD[31:0] invalid	E ⁽⁵⁾ - 2	E ⁽⁵⁾ + 2	ns
GNF5	$t_{w(wenIV-cleIV)}$	Delay time, GPMC0_WEn invalid to GPMC0_BE0n_CLE invalid	F ⁽⁶⁾ - 2	F ⁽⁶⁾ + 2	ns

(14)

NO.	PARAMETER	DESCRIPTION	MIN	MAX	UNIT
GNF6	$t_{w(wenIV-csnIV)}$	Delay time, GPMC0_WEn invalid to GPMC0_CSn[x] ⁽¹³⁾ invalid	G ⁽⁷⁾ - 2	G ⁽⁷⁾ + 2	ns
GNF7	$t_{w(aleH-wenV)}$	Delay time, GPMC0_ADVn_ALE high to GPMC0_WEn valid	C ⁽³⁾ - 2	C ⁽³⁾ + 2	ns
GNF8	$t_{w(wenIV-aleIV)}$	Delay time, GPMC0_WEn invalid to GPMC0_ADVn_ALE invalid	F ⁽⁶⁾ - 2	F ⁽⁶⁾ + 2	ns
GNF9	$t_{c(wen)}$	Cycle time, write		H ⁽⁸⁾	ns
GNF10	$t_{d(csnV-oenV)}$	Delay time, GPMC0_CSn[x] ⁽¹³⁾ valid to GPMC0_OEn_REn valid	I ⁽⁹⁾ - 2	I ⁽⁹⁾ + 2	ns
GNF13	$t_{w(oenV)}$	Pulse duration, GPMC0_OEn_REn valid		K ⁽¹⁰⁾	ns
GNF14	$t_{c(oen)}$	Cycle time, read	L ⁽¹¹⁾		ns
GNF15	$t_{w(oenIV-csnIV)}$	Delay time, GPMC0_OEn_REn invalid to GPMC0_CSn[x] ⁽¹³⁾ invalid	M ⁽¹²⁾ - 2	M ⁽¹²⁾ + 2	ns

- (1) $A = (WEOffTime - WEOnTime) \times (TimeParaGranularity + 1) \times GPMC_FCLK(14)$
- (2) $B = \sqrt{((WEOnTime - CSOnTime) \times (TimeParaGranularity + 1) + 0.5 \times (WEExtraDelay - CSEExtraDelay)) \times GPMC_FCLK(14)}$
- (3) $C = \sqrt{((WEOnTime - ADVOnTime) \times (TimeParaGranularity + 1) + 0.5 \times (WEExtraDelay - ADVExtraDelay)) \times GPMC_FCLK(14)}$
- (4) $D = (WEOnTime \times (TimeParaGranularity + 1) + 0.5 \times WEExtraDelay) \times GPMC_FCLK(14)$
- (5) $E = \sqrt{((WrCycleTime - WEOffTime) \times (TimeParaGranularity + 1) - 0.5 \times WEExtraDelay) \times GPMC_FCLK(14)}$
- (6) $F = \sqrt{((ADVWrOffTime - WEOffTime) \times (TimeParaGranularity + 1) + 0.5 \times (ADVExtraDelay - WEExtraDelay)) \times GPMC_FCLK(14)}$
- (7) $G = \sqrt{((CSWrOffTime - WEOffTime) \times (TimeParaGranularity + 1) + 0.5 \times (CSEExtraDelay - WEExtraDelay)) \times GPMC_FCLK(14)}$
- (8) $H = WrCycleTime \times (1 + TimeParaGranularity) \times GPMC_FCLK(14)$
- (9) $I = \sqrt{((OEOnTime - CSOnTime) \times (TimeParaGranularity + 1) + 0.5 \times (OEEExtraDelay - CSEExtraDelay)) \times GPMC_FCLK(14)}$
- (10) $K = (OEOffTime - OEOnTime) \times (1 + TimeParaGranularity) \times GPMC_FCLK(14)$
- (11) $L = RdCycleTime \times (1 + TimeParaGranularity) \times GPMC_FCLK(14)$
- (12) $M = \sqrt{((CSRdOffTime - OEOffTime) \times (TimeParaGranularity + 1) + 0.5 \times (CSEExtraDelay - OEEExtraDelay)) \times GPMC_FCLK(14)}$
- (13) In GPMC_CSn[x], x is equal to 0, 1, 2 or 3.
- (14) 133MHz GPMC_FCLK selected - CTRLMMR_GPMC_CLKSEL[0] CLK_SEL = 0 = MAIN_PLL0_HSDIV3_CLKOUT (133/100/80 MHz)

ADVANCE INFORMATION

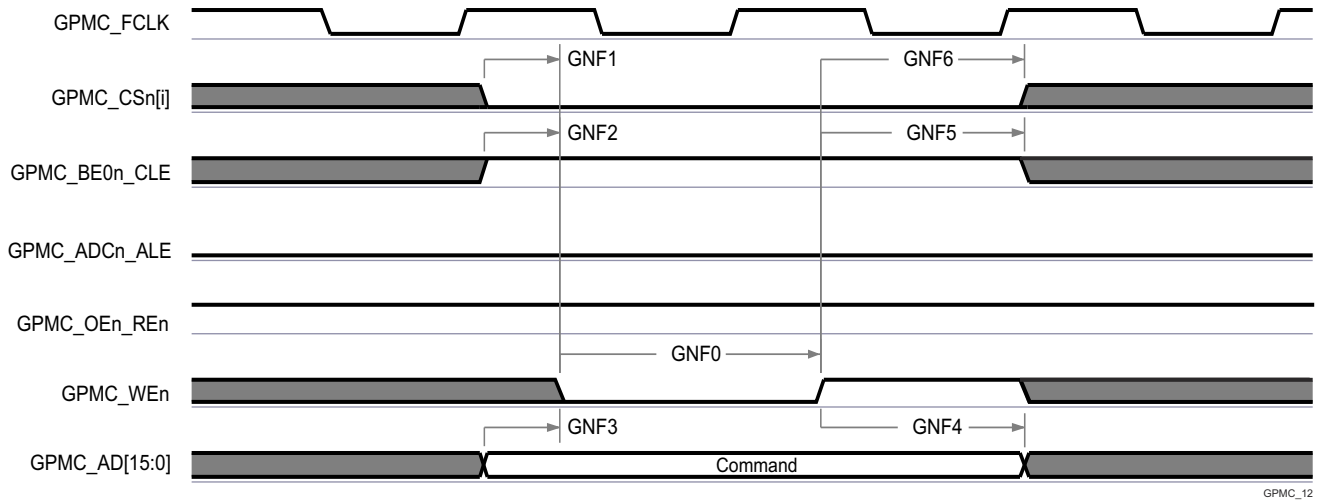

A. In GPMC_CSn[i], i is equal to 0, 1, 2 or 3.

图 7-29. GPMC and NAND Flash — Command Latch Cycle

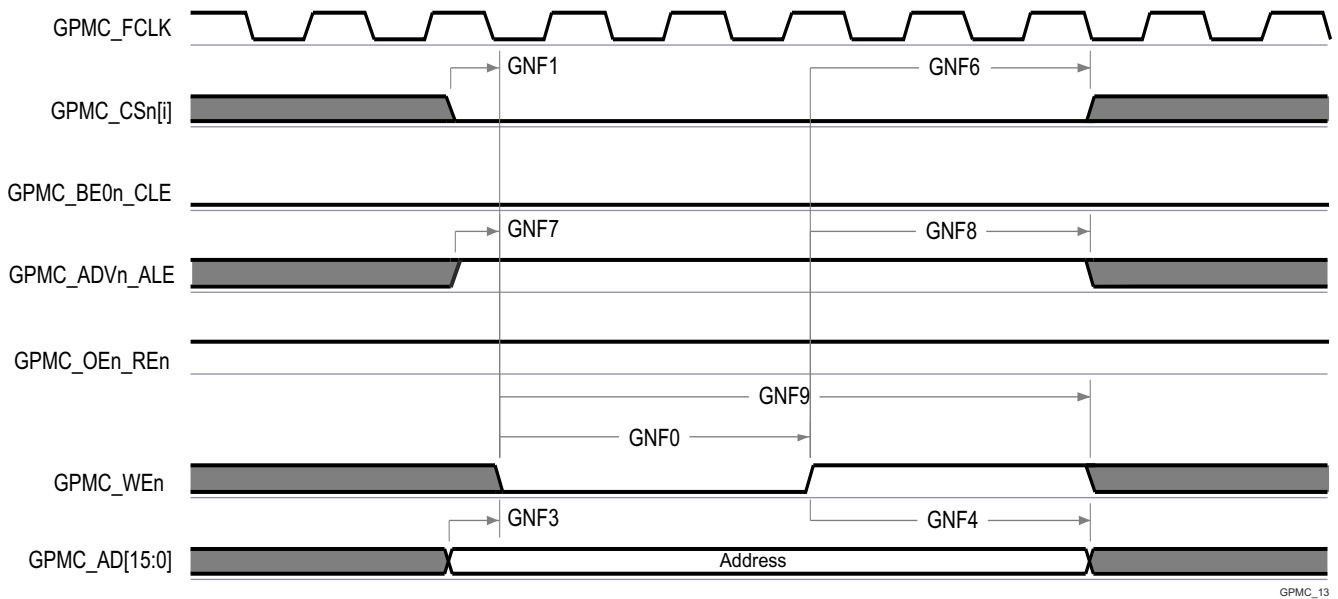

A. In GPMC_CSn[i], i is equal to 0, 1, 2 or 3.

图 7-30. GPMC and NAND Flash — Address Latch Cycle

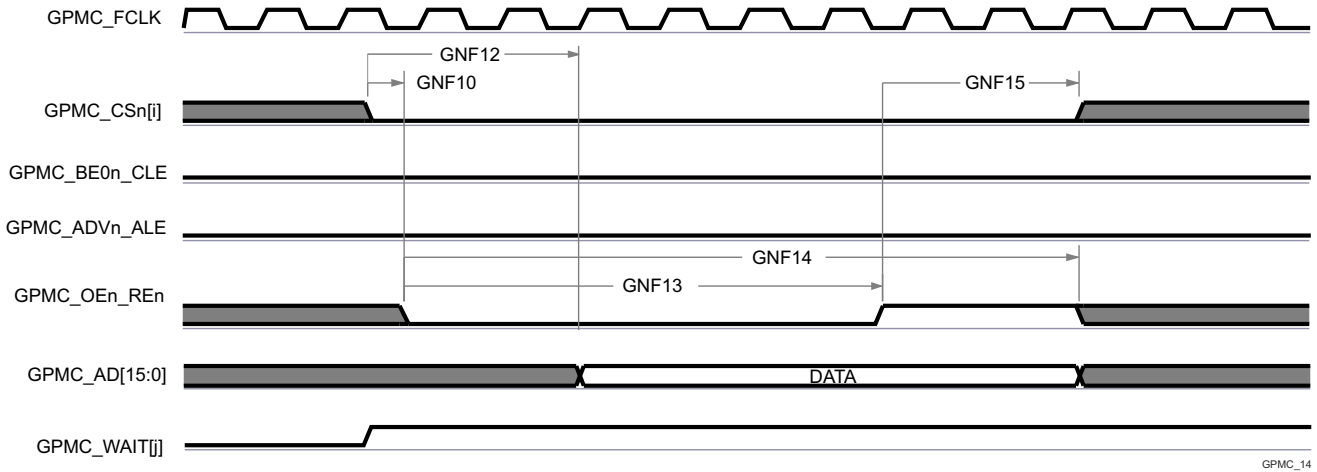

GPMC_14

- A. GNF12 parameter illustrates amount of time required to internally sample input data. It is expressed in number of GPMC functional clock cycles. From start of read cycle and after GNF12 functional clock cycles, input data will be internally sampled by active functional clock edge. GNF12 value must be stored inside AccessTime register bits field.
- B. GPMC_FCLK is an internal clock (GPMC functional clock) not provided externally.
- C. In GPMC_CS*n*[*i*], *i* is equal to 0, 1, 2 or 3. In GPMC_WAIT[j], *j* is equal to 0 or 1.

图 7-31. GPMC and NAND Flash — Data Read Cycle

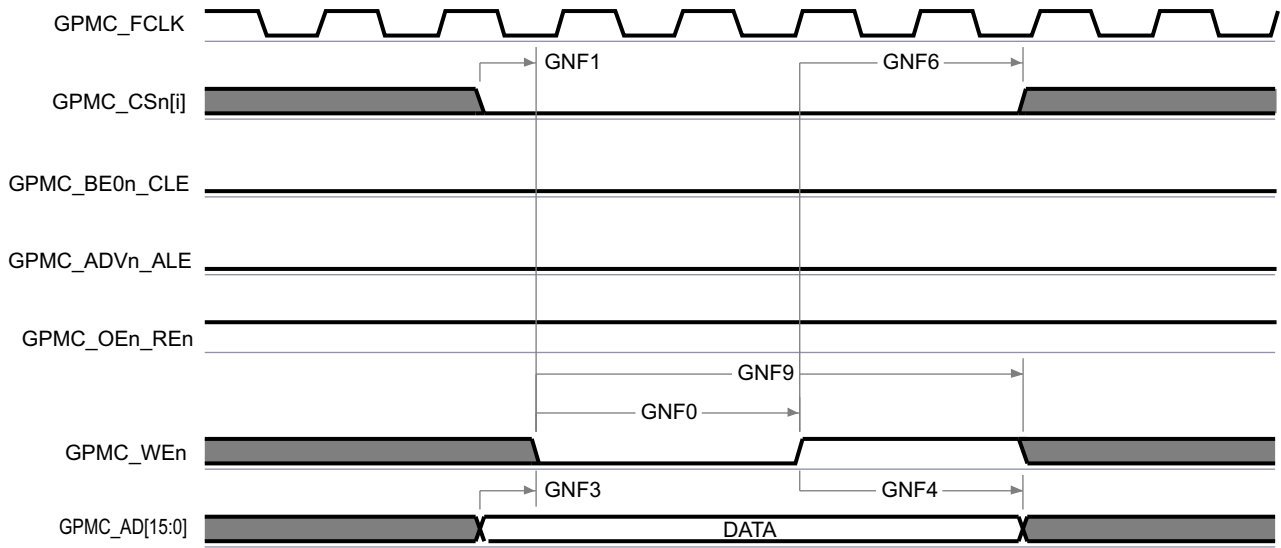

GPMC_15

- A. In GPMC_CS*n*[*i*], *i* is equal to 0, 1, 2 or 3.

图 7-32. GPMC and NAND Flash — Data Write Cycle

7.10.4.8 I2C

For more details about features and additional description information on the device Inter-Integrated Circuit, see the corresponding subsections within *Signal Descriptions* and *Detailed Description* sections.

I2C Timing Requirements

NO. ⁽¹⁾ (6)	PARAMETER	DESCRIPTION	MODE	MIN	MAX	UNIT
I2C						
I1	t _{c(SCL)}	Cycle time, SCL	Standard	10000		ns
			Fast	2500		ns

NO. ⁽¹⁾ (6)	PARAMETER	DESCRIPTION	MODE	MIN	MAX	UNIT
12	t _{su} (SCLH-SDAL)	Setup time, SCL high before SDA low (for a repeated START condition)	Standard	4700		ns
			Fast	600		ns
13	t _h (SDAL-SCLL)	Hold time, SCL low after SDA low (for a START and a repeated START condition)	Standard	4000		ns
			Fast	9000		ns
14	t _w (SCLL)	Pulse duration, SCL clock low	Standard	4700		ns
			Fast	1300		ns
15	t _w (SCLH)	Pulse duration, SCL clock high	Standard	4000		ns
			Fast	600		ns
16	t _{su} (SDAV-SCLH)	Setup time, SDA valid before SCL high	Standard	250		ns
			Fast	100 ⁽²⁾		ns
17	t _h (SCLL-SDAV)	Hold time, SDA valid after SCL low	Standard	0 ⁽³⁾	3450 ⁽⁴⁾	ns
			Fast	0 ⁽³⁾	900 ⁽⁴⁾	ns
18	t _w (SDAH)	Pulse duration, SDA high between STOP and START conditions	Standard	4700		ns
			Fast	1300		ns
19	t _r (SDA)	Rise time, SDA	Standard		1000	ns
			Fast	20 × (V _{dd} / 5.5V) ^{(5) (7)}	300 ^{(5) (7)}	ns
110	t _r (SCL)	Rise time, SCL	Standard		1000	ns
			Fast	20 × (V _{dd} / 5.5V) ^{(5) (7)}	300 ^{(5) (7)}	ns
111	t _f (SDA)	Fall time, SDA	Standard		300	ns
			Fast	20 × (V _{dd} / 5.5V) ^{(5) (7)}	300 ^{(5) (7)}	ns
112	t _f (SCL)	Fall time, SCL	Standard		300	ns
			Fast	20 × (V _{dd} / 5.5V)	300	ns
113	t _{su} (SCLH-SDAH)	Setup time, SCL high before SDA high (for STOP condition)	Standard	4000		ns
			Fast	600		ns
114	t _w (SP)	Pulse duration, spike (must be suppressed)	Standard			ns
			Fast	0	50	ns
115	t _{skew}	Skew	Standard		3	ns
			Fast		3	ns
116	C _b	Capacitive load for each bus line	Standard		400	pF
			Fast		400	pF

- (1) The I2C pins SDA and SCL do not feature fail-safe I/O buffers. These pins could potentially draw current when the device is powered down.
- (2) A Fast-mode I2C-bus™ device can be used in a Standard-mode I2C-bus system, but the requirement $t_{su}(SDA-SCLH) \geq 250$ ns must then be met. This will automatically be the case if the device does not stretch the LOW period of the SCL signal. If such a device does stretch the LOW period of the SCL signal, it must output the next data bit to the SDA line $t_{r,max} + t_{su}(SDA-SCLH) = 1000 + 250 = 1250$ ns (according to the Standard-mode I2C-Bus Specification) before the SCL line is released.
- (3) A device must internally provide a hold time of at least 300 ns for the SDA signal (referred to the V_{IHmin} of the SCL signal) to bridge the undefined region of the falling edge of SCL.
- (4) The maximum t_h(SDA-SCLL) has only to be met if the device does not stretch the low period [t_w(SCLL)] of the SCL signal.
- (5) C_b = total capacitance of one bus line in pF. If mixed with HS-mode devices, faster fall-times are allowed.
- (6) Software must properly configure the I2C module registers to achieve the timings shown in this table. See the Device TRM for details.
- (7) These timings apply only to MCU_I2C0, WKUP_I2C0, and MAIN_I2C[0:1]. All other instances of I2C use standard LVCMOS buffers to emulate open-drain buffers and their rise/fall times should be referenced in the device IBIS model.

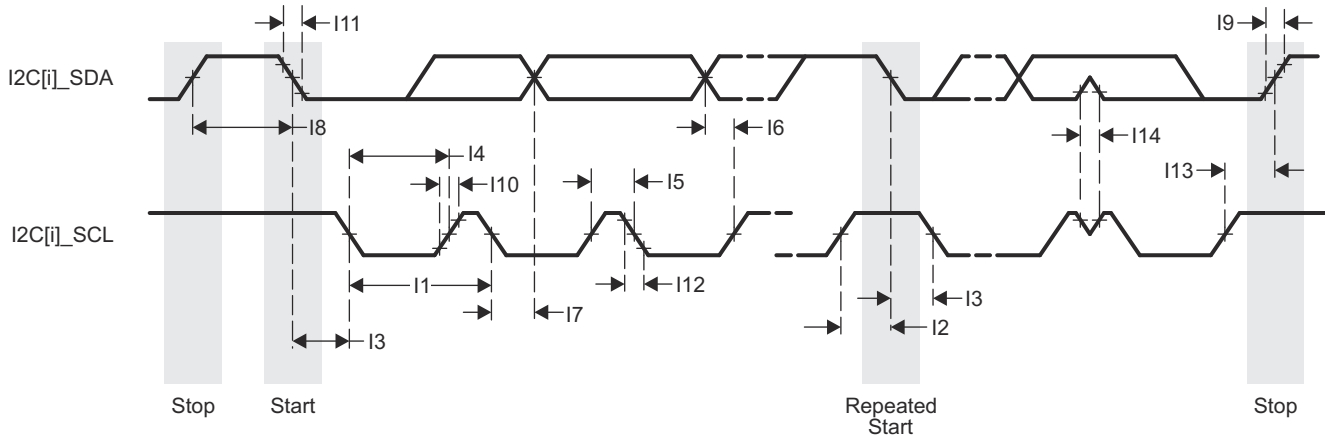

- A. $i = 0$ to 1 for MCU domain
 $i = 0$ to 3 for MAIN domain

图 7-33. I2C Receive Timing

7.10.4.9 LIN

For more information, see *Local Interconnect Network (LIN) Module* section in the device TRM.

LIN Timing Conditions

PARAMETER		MIN	MAX	UNIT
INPUT CONDITIONS				
SR_i	Input Slew Rate	2	15	V/ns
OUTPUT CONDITIONS				
C_L	Output Load Capacitance	5	20	pF

LIN Timing Requirements

NO.	PARAMETER	DESCRIPTION	MIN	MAX	UNIT
LIN2	$t_{d(LINn_RX)}$	Delay time, LINn_RX shift register to LINn_RX pin	0	10	ns

LIN Switching Characteristics

NO.	PARAMETER	DESCRIPTION	MIN	MAX	UNIT
LIN4	$t_{d(LINn_TX)}$	Delay time, LINn_TX shift register to LINn_TX pin		10	ns

7.10.4.10 MCAN

For more details about features and additional description information on the device Controller Area Network Interface, see the corresponding subsections within *Signal Descriptions* and *Detailed Description* sections.

备注

The device has multiple MCAN modules. MCANn is a generic prefix applied to MCAN signal names, where n represents the specific MCAN module.

For more information, see *Controller Area Network (MCAN)* section in the device TRM.

MCAN Timing Conditions

PARAMETER		MIN	MAX	UNIT
INPUT CONDITIONS				

PARAMETER		MIN	MAX	UNIT
SR _I	Input Slew Rate	2	15	V/ns
OUTPUT CONDITIONS				
C _L	Output Load Capacitance	5	20	pF

MCAN Switching Characteristics

NO.	PARAMETER	DESCRIPTION	MIN	MAX	UNIT
M1	t _{d(MCAN_TX)}	Delay time, transmit shift register to MCANn_TX pin		10	ns
M2	t _{d(MCAN_RX)}	Delay time, MCANn_RX pin to receive shift register		10	ns

7.10.4.11 MCSPI

For more details about features and additional description information on the device Serial Port Interface, see the corresponding subsections within *Signal Descriptions* and *Detailed Description* sections.

For more information, see *Multichannel Serial Peripheral Interface (MCSPI)* section in the device TRM.

SPI Timing Conditions

PARAMETER		MIN	MAX	UNIT
INPUT CONDITIONS				
SR _I	Input Slew Rate	2	8.5	V/ns
OUTPUT CONDITIONS				
C _L	Output Load Capacitance	2	24	pF

SPI Master Mode Timing Requirements

NO.	PARAMETER	DESCRIPTION	MIN	MAX	UNIT
Normal Mode					
SM4	t _{su(MISO-SPICLK)}	Setup time, spi_d[x] valid before spi_sclk active edge	2		ns
SM5	t _{h(SPICLK-MISO)}	Hold time, spi_d[x] valid after spi_sclk active edge	3		ns

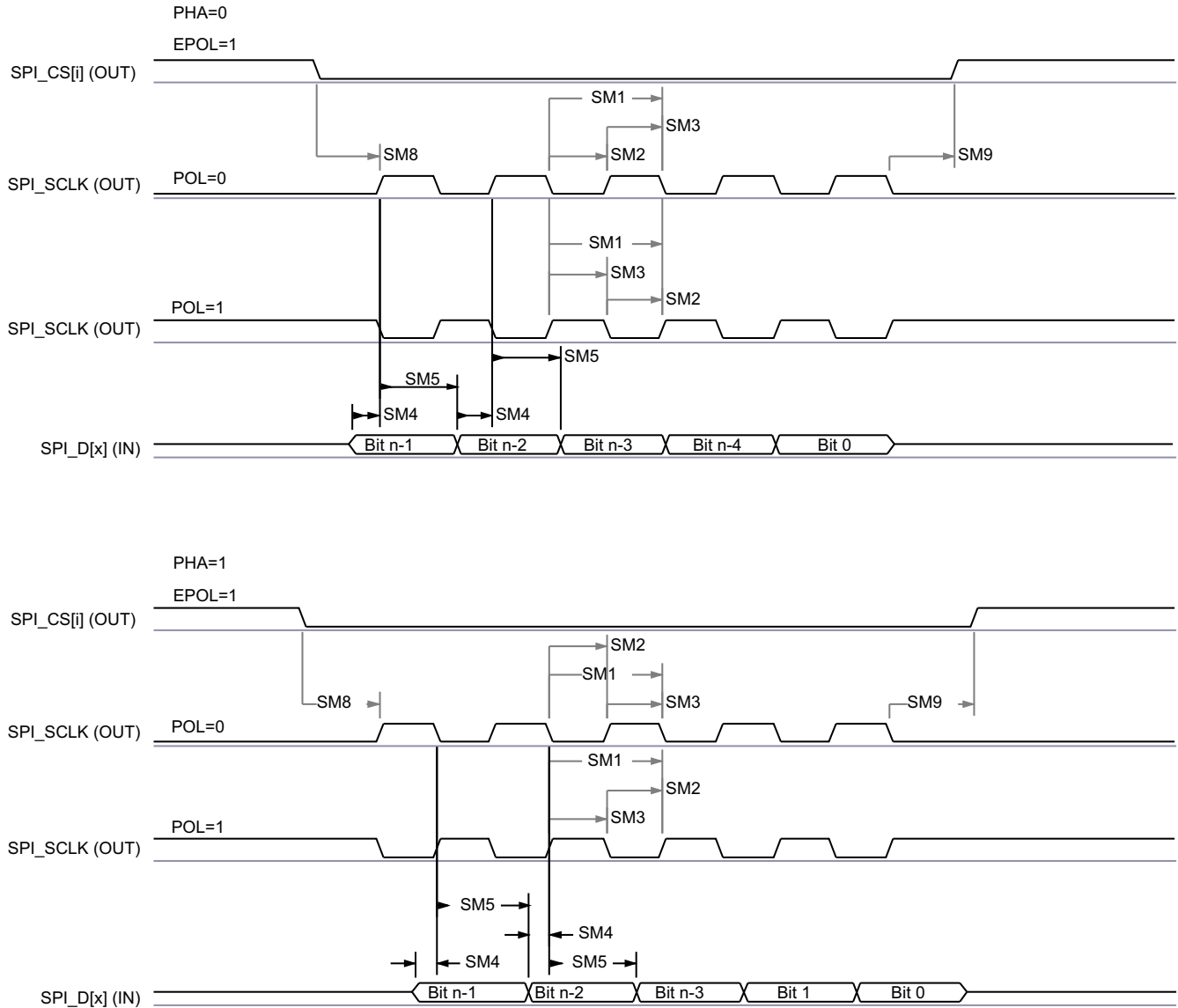

SPRS008_TIMING_M0_SPI_02

图 7-34. SPI Master Mode Receive Timing

SPI Master Mode Switching Characteristics (Clock Phase = 0)

NO.	PARAMETER	DESCRIPTION	MIN	MAX	UNIT
Normal Mode					
SM1	$t_c(\text{SPICLK})$	Cycle time, spi_sclk	20	5	ns
SM2	$t_w(\text{SPICLK}_L)$	Typical Pulse duration, spi_sclk low	$-1 + 0.5P^{(1)}$		ns
SM3	$t_w(\text{SPICLK}_H)$	Typical Pulse duration, spi_sclk high	$-1 + 0.5P^{(1)}$		ns
SM6	$t_d(\text{SPICLK-SIMO})$	Delay time, spi_sclk active edge to spi_d[x] transition	-3	2	ns
SM7	$t_{sk}(\text{CS-SIMO})$	Delay time, spi_cs[x] active to spi_d[x] transition	5		ns
SM8	$t_d(\text{SPICLK-CS})$	Delay time, spi_cs[x] active to spi_sclk first edge	PHA = 0	$-4 + B^{(3)}$	ns
			PHA = 1	$-4 + A^{(2)}$	ns

NO.	PARAMETER	DESCRIPTION	MIN	MAX	UNIT
SM9	$t_{d(SPICLK-CS)}$	Delay time, spi_sclk last edge to spi_cs[x] inactive	PHA = 0	- 4 + A ⁽²⁾	ns
			PHA = 1	- 4 + B ⁽³⁾	ns

- (1) P = SPICLK period in ns.
- (2) When P = 20.8 ns, A = (TCS + 1) * TSPICLKREF, where TCS is a bit field of the SPI_CH(i)CONF register. When P > 20.8 ns, A = (TCS + 0.5) * Fratio * TSPICLKREF, where TCS is a bit field of the SPI_CH(i)CONF register.
- (3) B = (TCS + .5) * TSPICLKREF, where TCS is a bit field of the SPI_CH(i)CONF register and Fratio = Even >= 2.

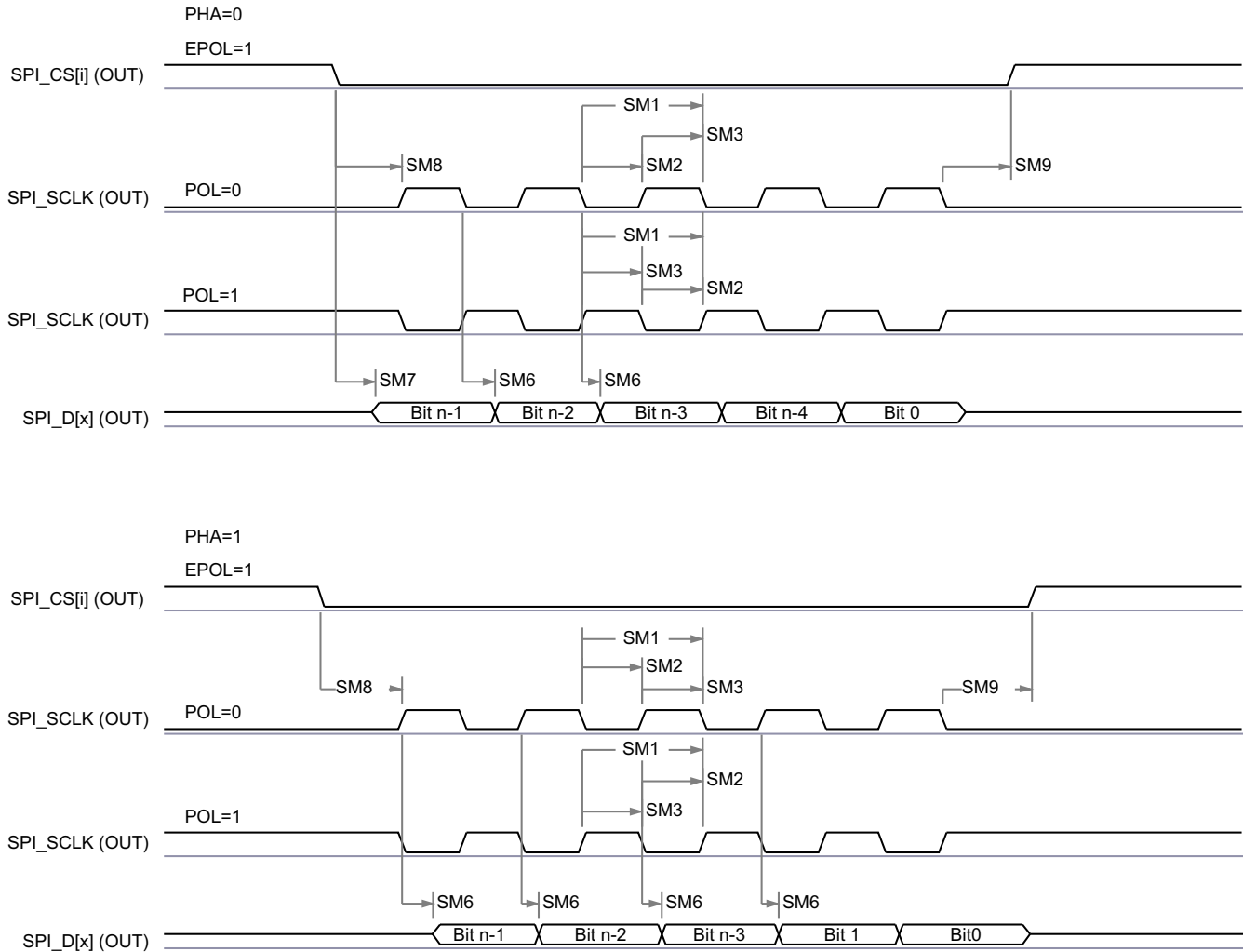

SPRS08_TIMING_McSPI_01

图 7-35. SPI Master Mode Transmit Timing

SPI Slave Mode Timing Requirements

NO.	PARAMETER	DESCRIPTION	MIN	MAX	UNIT
SS1	$t_c(SPICLK)$	Cycle time, spi_sclk	40		ns
SS2	$t_w(SPICLKL)$	Typical Pulse duration, spi_sclk low	$18.45 \times P^{(1)}$		ns
SS3	$t_w(SPICLKH)$	Typical Pulse duration, spi_sclk high	$18.45 \times P^{(1)}$		ns
SS4	$t_{su}(SIMO-SPICLK)$	Setup time, spi_d[x] valid before spi_sclk active edge	5		ns
SS5	$t_h(SPICLK-SIMO)$	Hold time, spi_d[x] valid after spi_sclk active edge	5		ns

NO.	PARAMETER	DESCRIPTION	MIN	MAX	UNIT
SS8	$t_{su}(CS-SPICLK)$	Setup time, spi_cs[x] valid before spi_sclk first edge	5		ns
SS9	$t_h(SPICLK-CS)$	Hold time, spi_cs[x] valid after spi_sclk last edge	5		ns

(1) P = SPICLK period.

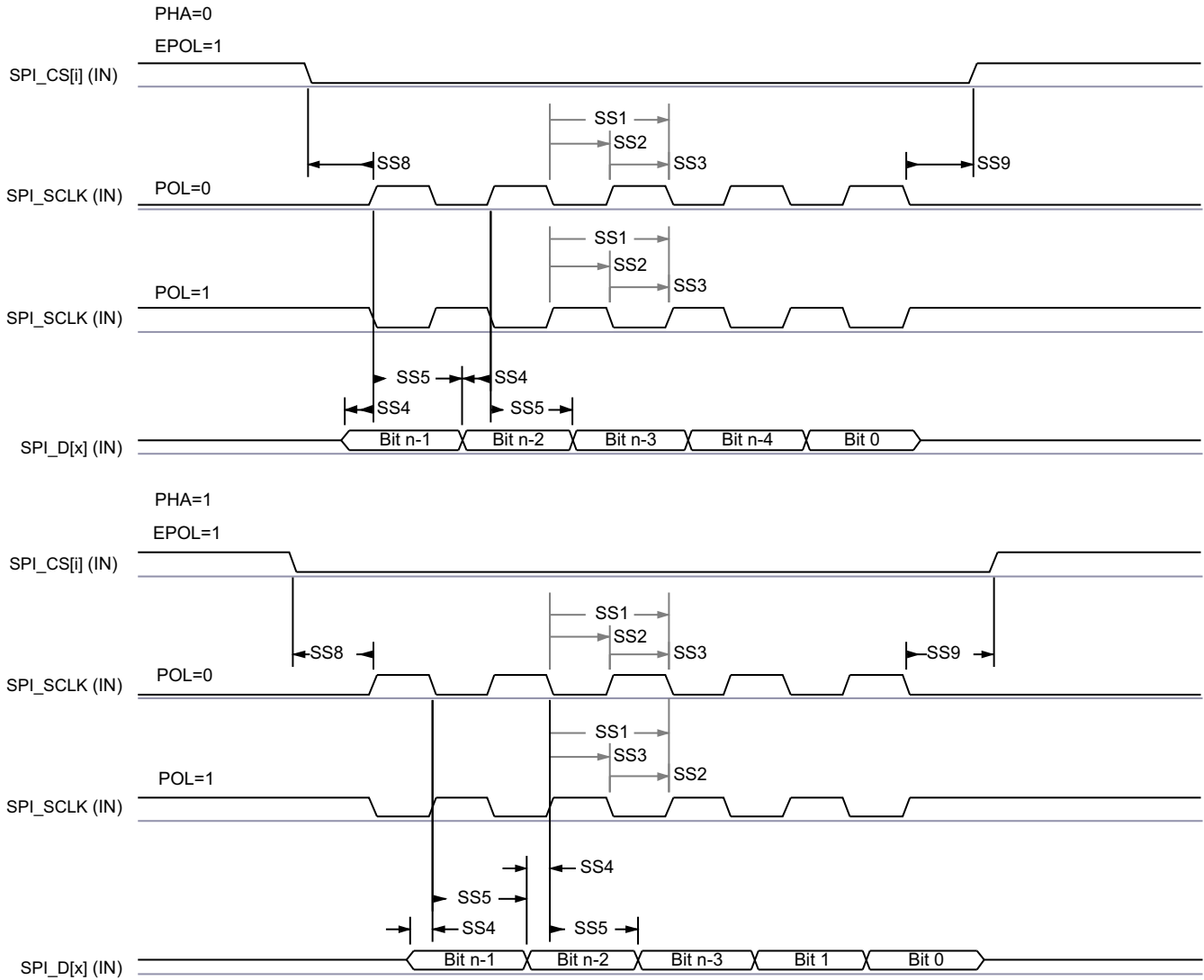

SPRSP08_TIMING_McSPI_04

图 7-36. SPI Slave Mode Receive Timing

SPI Slave Mode Switching Characteristics

NO.	PARAMETER	DESCRIPTION	MIN	MAX	UNIT
Normal Mode					
SS6	$t_d(SPICLK-SOMI)$	Delay time, spi_sclk active edge to mcspi_somi transition	2	17.12	ns
SS7	$t_{sk}(CS-SOMI)$	Delay time, spi_cs[x] active edge to mcspi_somi transition	20.95		ns

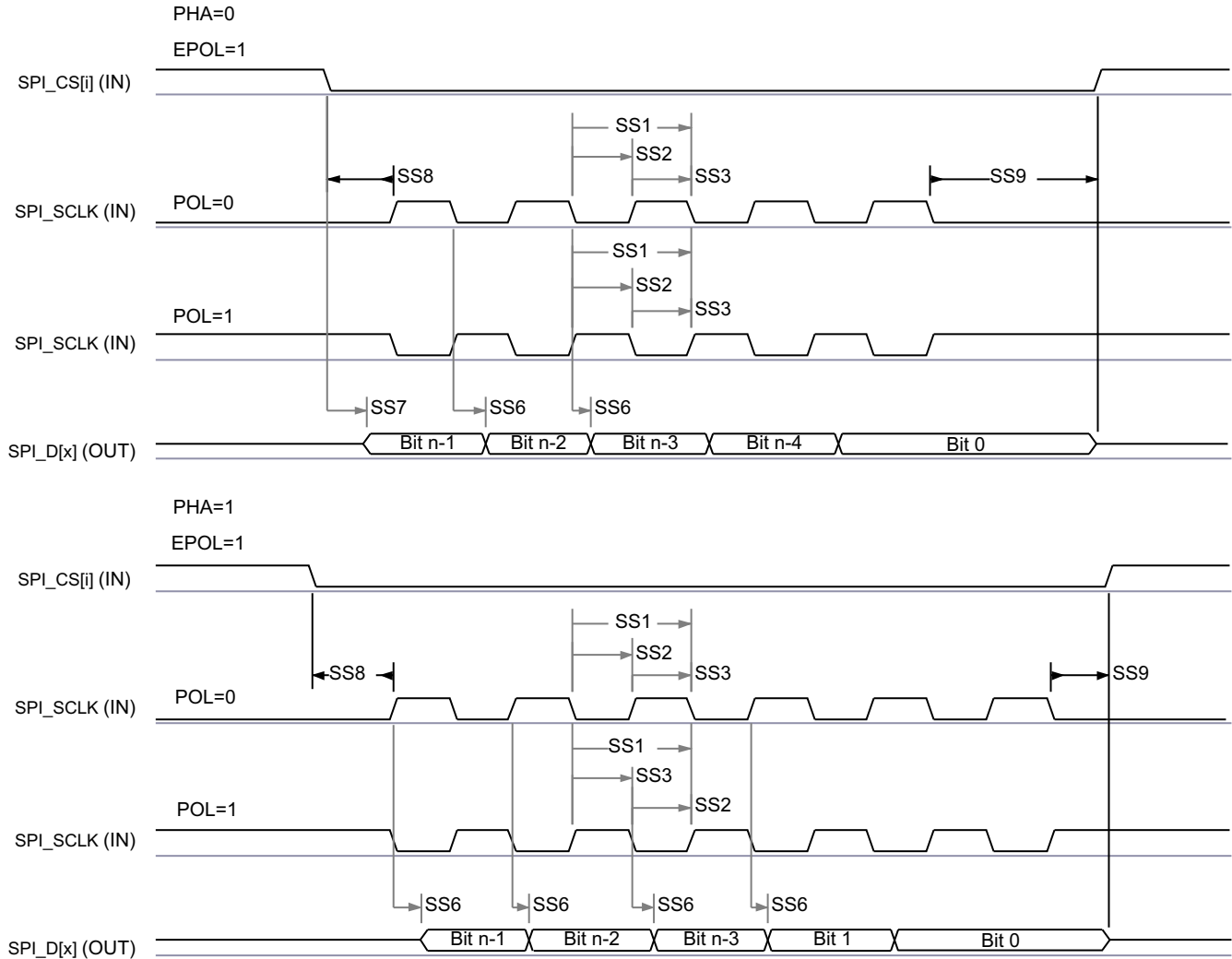

SPRSP08_TIMING_McSPI_03

图 7-37. SPI Slave Mode Transmit Timing

7.10.4.12 MMCSDB

The MMCSDB Host Controller provides an interface to embedded Multi-Media Card (MMC), Secure Digital (SD), and Secure Digital IO (SDIO) devices. The MMCSDB Host Controller deals with MMC/SD/SDIO protocol at transmission level, data packing, adding cyclic redundancy checks (CRCs), start/end bit insertion, and checking for syntactical correctness.

For more details about MMCSDB interfaces, see the corresponding MMC0 and MMC1 subsections within *Signal Descriptions* and *Detailed Description* sections.

For more information, see *Multi-Media Card/Secure Digital (MMCSDB) Interface* section in *Peripherals* chapter in the device TRM.

MMC1 Timing Conditions

PARAMETER		MODE	MIN	MAX	UNIT
INPUT CONDITIONS					
SR _i	Input Slew Rate	Default Speed	0.69	2.06	V/ns
		High Speed	0.69	2.06	V/ns
OUTPUT CONDITIONS					

PARAMETER		MODE	MIN	MAX	UNIT
C _L	Output Load Capacitance	Default Speed	1	10	pF
		High Speed	1	10	pF

MMC1 Timing Requirements - SD Card Default Speed Mode

NO.	PARAMETER	DESCRIPTION	MIN	MAX	UNIT
DS1	t _{su(cmdV-clkH)}	Setup time, MMC1_CMD valid before MMC1_CLK rising edge	2.15		ns
DS2	t _{h(clkH-cmdV)}	Hold time, MMC1_CMD valid after MMC1_CLK rising edge	19.67		ns
DS3	t _{su(dV-clkH)}	Setup time, MMC1_DAT[3:0] valid before MMC1_CLK rising edge	2.15		ns
DS4	t _{h(clkH-dV)}	Hold time, MMC1_DAT[3:0] valid after MMC1_CLK rising edge	19.67		ns



图 7-38. MMC1 - Default Speed - Receive Mode

MMC1 Switching Characteristics - SD Card Default Speed Mode

NO.	PARAMETER	DESCRIPTION	MIN	MAX	UNIT
	f _{op(clk)}	Operating frequency, MMC1_CLK		25	MHz
DS5	t _{c(clk)}	Operating period, MMC1_CLK		40	ns
DS6	t _{w(clkH)}	Pulse duration, MMC1_CLK high	18.7		ns
DS7	t _{w(clkL)}	Pulse duration, MMC1_CLK low	18.7		ns
DS8	t _{d(clkL-cmdV)}	Delay time, MMC1_CLK falling edge to MMC1_CMD transition	- 14.1	14.1	ns
DS9	t _{d(clkL-dV)}	Delay time, MMC1_CLK falling edge to MMC1_DAT[3:0] transition	- 14.1	14.1	ns

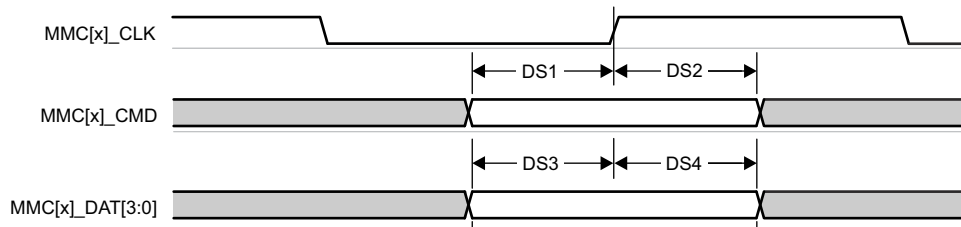

图 7-39. MMC1 - Default Speed - Transmit Mode

MMC1 Timing Requirements - SD Card High Speed

NO.	PARAMETER	DESCRIPTION	MIN	MAX	UNIT
HS1	t _{su(cmdV-clkH)}	Setup time, MMC1_CMD valid before MMC1_CLK rising edge	2.15		ns

NO.	PARAMETER	DESCRIPTION	MIN	MAX	UNIT
HS2	$t_{h(\text{clkH-cmdV})}$	Hold time, MMC1_CMD valid after MMC1_CLK rising edge	2.67		ns
HS3	$t_{su(\text{dV-clkH})}$	Setup time, MMC1_DAT[3:0] valid before MMC1_CLK rising edge	2.15		ns
HS4	$t_{h(\text{clkH-dV})}$	Hold time, MMC1_DAT[3:0] valid after MMC1_CLK rising edge	2.67		ns

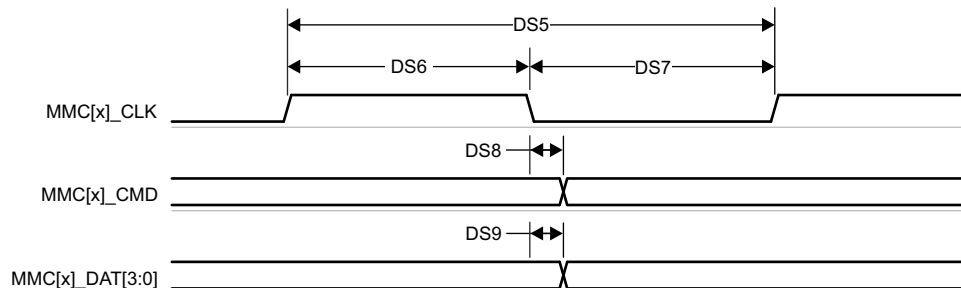

图 7-40. MMC1 - High Speed - Receive Mode

MMC1 Switching Characteristics - SD Card High Speed

NO.	PARAMETER	DESCRIPTION	MIN	MAX	UNIT
	$f_{op(\text{clk})}$	Operating frequency, MMC1_CLK		50	MHz
HS5	$t_{c(\text{clk})}$	Operating period, MMC1_CLK		20	ns
HS6	$t_{w(\text{clkH})}$	Pulse duration, MMC1_CLK high	9.2		ns
HS7	$t_{w(\text{clkL})}$	Pulse duration, MMC1_CLK low	9.2		ns
HS8	$t_{d(\text{clkL-cmdV})}$	Delay time, MMC1_CLK falling edge to MMC1_CMD transition	- 7.35	3.35	ns
HS9	$t_{d(\text{clkL-dV})}$	Delay time, MMC1_CLK falling edge to MMC1_DAT[3:0] transition	- 7.35	3.35	ns

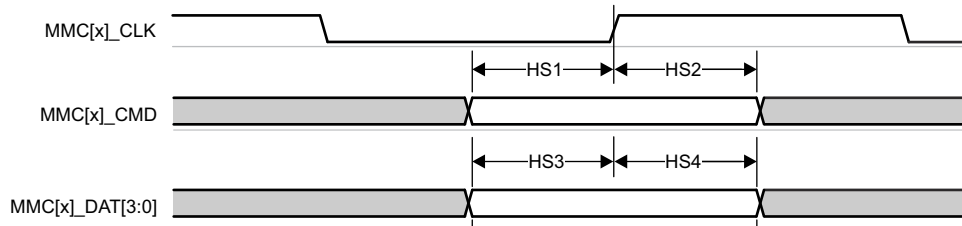

图 7-41. MMC1 - High Speed - Transmit Mode

7.10.4.13 QSPI

For more details about features and additional description information on the device Quad Serial Peripheral Interface, see the corresponding subsections within *Signal Descriptions* and *Detailed Description* sections.

For more information, see *Octal Serial Peripheral Interface (OSPI)* section in the device TRM.

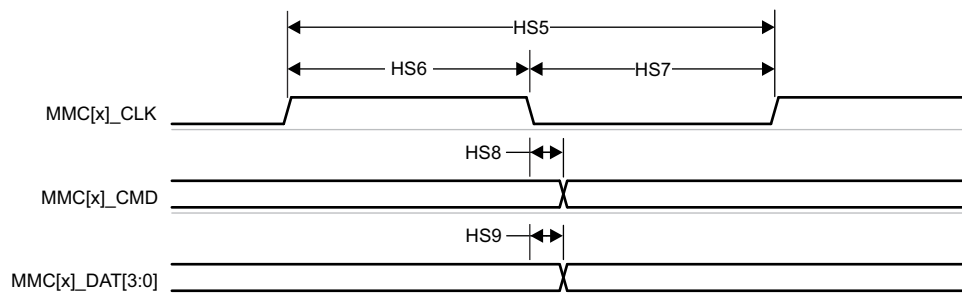
QSPI Timing Conditions

PARAMETER	MIN	MAX	UNIT
INPUT CONDITIONS			
SR_i Input Slew Rate	1	4	V/ns
OUTPUT CONDITIONS			

PARAMETER		MIN	MAX	UNIT
C _L	Output Load Capacitance	2	8	pF

QSPI Timing Requirements

(1) (2)

NO.	PARAMETER	DESCRIPTION	MODE	MIN	MAX	UNIT
Q12	t _{su(D-RTCLK)}	Setup time, d[3:0] valid before falling rtclk edge	Manual IO Timing Modes, Clock Mode 0	2.69		ns
	t _{su(D-SCLK)}	Setup time, d[3:0] valid before falling sclk edge	Manual IO Timing Modes, Clock Mode 3	5.7		ns
Q13	t _{h(RTCLK-D)}	Hold time, d[3:0] valid after falling rtclk edge	Manual IO Timing Modes, Clock Mode 0	-0.1		ns
	t _{h(SCLK-D)}	Hold time, d[3:0] valid after falling sclk edge	Manual IO Timing Modes, Clock Mode 3	0.1		ns

- (1) Clock Modes 1 and 2 are not supported.
- (2) The device captures data on the falling clock edge in Clock Mode 0 and 3, as opposed to the traditional rising clock edge. Although non-standard, the falling-edge-based setup and hold timings have been designed to be compatible with standard SPI devices that launch data on the falling edge in Clock Modes 0 and 3.

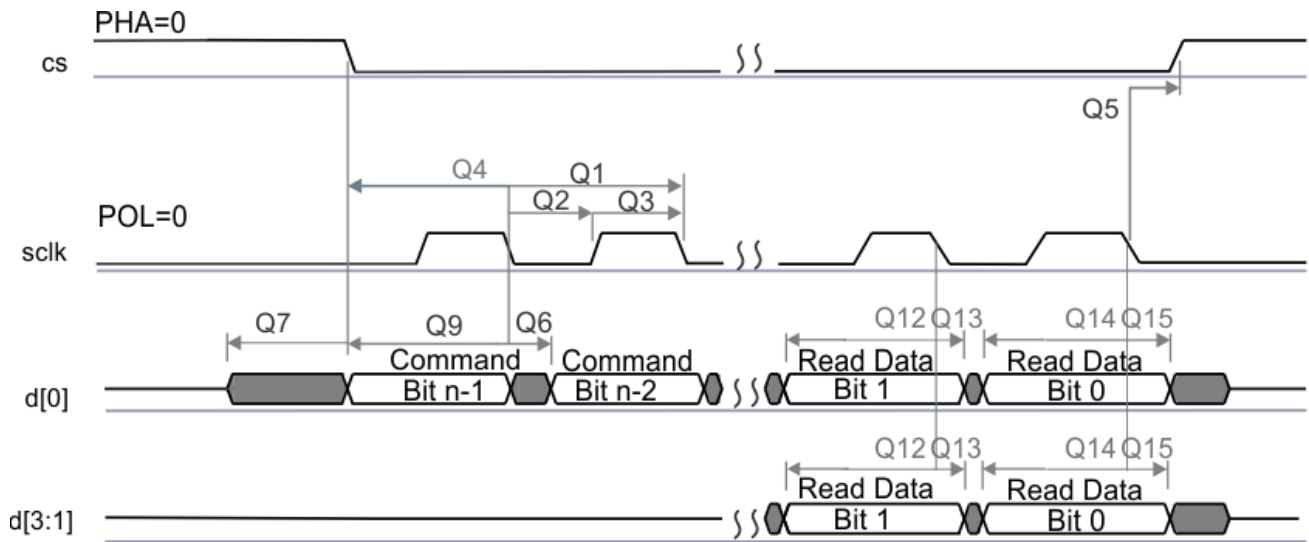

SPRS85v TIMING OSP11 02

图 7-42. QSPI Timing Requirements

QSPI Switching Characteristics

NO.	PARAMETER	DESCRIPTION	MODE	MIN	MAX	UNIT
Q1	t _{c(SCLK)}	Cycle time, sclk	Manual IO Timing Modes, Clock Mode 0	10.41		ns
			Manual IO Timing Modes, Clock Mode 3	13.02		ns
Q2	t _{w(SCLKL)}	Pulse duration, sclk low	All	Y ⁽⁴⁾ × P ⁽¹⁾ - 1		ns
Q3	t _{w(SCLKH)}	Pulse duration, sclk high	All	Y ⁽⁴⁾ × P ⁽¹⁾ - 1		ns

NO.	PARAMETER	DESCRIPTION	MODE	MIN	MAX	UNIT
Q4	$t_{d(CS-SCLK)}$	Delay time, sclk falling edge to cs active edge, CS1:0	Manual IO Timing Modes	$-M^{(2)} \times P^{(1)} - 2$	$-M^{(2)} \times P^{(1)} + 2$	ns
Q5	$t_{d(SCLK-CS)}$	Delay time, sclk falling edge to cs inactive edge, CS1:0	Manual IO Timing Modes	$N^{(3)} \times P^{(1)} - 2$	$N^{(3)} \times P^{(1)} + 2$	ns
Q6	$t_{d(SCLK-D0)}$	Delay time, sclk falling edge to d[0] transition	Manual IO Timing Modes	-1	2	ns
Q7	$t_{ena(CS-D0LZ)}$	Enable time, cs active edge to d[0] drive (lo-z)	All	$-P^{(1)} - 2$	$-P^{(1)} + 2$	ns
Q8	$t_{dis(CS-D0Z)}$	Disable time, cs active edge to d[0] tri-stated (hi-z)	All	$-P^{(1)} - 2$	$-P^{(1)} + 2$	ns
Q9	$t_{d(SCLK-D0)}$	Delay time, sclk first falling edge to first d[0] transition	Manual IO Timing Modes, PHA=0 Only	$-P^{(1)} - 1$	$-P^{(1)} + 2$	ns

- (1) P = SCLK period
 (2) M=QSPI_SPI_DC_REG.DDx + 1 when Clock Mode 0. M=QSPI_SPI_DC_REG.DDx when Clock Mode 3.
 (3) N = 2 when Clock Mode 0. N = 3 when Clock Mode 3.
 (4) Y = 0.5 when DCLK_DIV is 0 or ODD
 Y = (DCLK_DIV/2)/(DCLK_DIV+1) when DCLK_DIV is EVEN

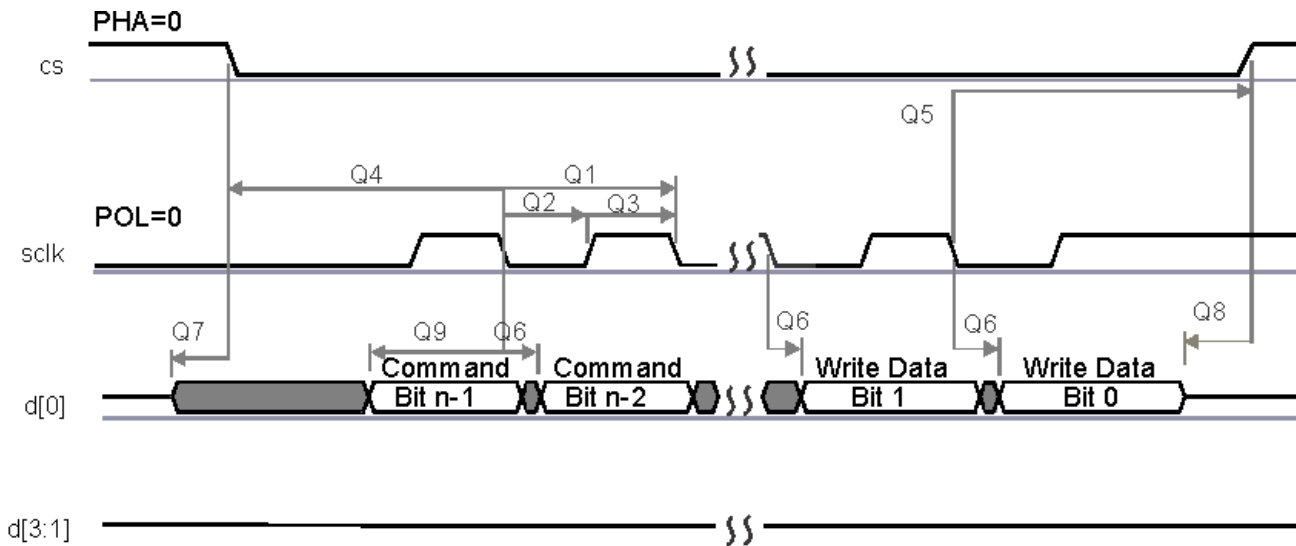

SPRS88L_TIMING_QSPI1_D4

图 7-43. QSPI Switching Characteristics

7.10.4.14 PRU_ICSSM

The device has integrated a single Programmable Real-Time Unit Subsystem and Industrial Communication Subsystem (PRU_ICSSM0). The programmable nature of the PRU cores, along with their access to pins, events and all device resources, provides flexibility in implementing fast real-time responses, specialized data handling operations, custom peripheral interfaces, and in offloading tasks from the other processor cores in the device.

For more details about features and additional description information on the device PRU_ICSSM, see the corresponding subsections within *Signal Descriptions* and *Detailed Description* sections.

备注

The PRU_ICSSM0 supports an internal wrapper multiplexing that expands the device top-level multiplexing.

7.10.4.14.1 PRU_ICSSM Programmable Real-Time Unit (PRU)

备注

The PRU_ICSSM PRU signals have different functionality depending on the mode of operation. The signal naming in this section matches the naming used in the *PRU Module Interface* section in the device TRM.

PRU_ICSSM PRU Timing Conditions

PARAMETER		MIN	MAX	UNIT
INPUT CONDITIONS				
SR _i	Input Slew Rate	1	3	V/ns
OUTPUT CONDITIONS				
C _L	Output Load Capacitance	2	30	pF

PRU_ICSSM PRU Switching Characteristics - Direct Output Mode

NO.	PARAMETER	DESCRIPTION	MIN	MAX	UNIT
PRDO1	t _{sk} (PRU_GPO)	PRU_GPO (data out) skew		3	ns

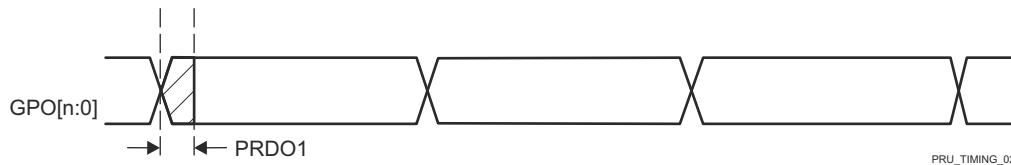

PRU_TIMING_02

A. n in GPO[n:0] = 19.

图 7-44. PRU_ICSSM PRU Direct Output Timing

PRU_ICSSM PRU Timing Requirements - Parallel Capture Mode

NO.	PARAMETER	DESCRIPTION	MIN	MAX	UNIT
PRPC1	t _c (PRU_CLOCK)	Cycle time, PRU_CLOCK	20		ns
PRPC2	t _w (PRU_CLOCKL)	Pulse duration, PRU_CLOCK Low	10		ns
PRPC3	t _w (PRU_CLOCKH)	Pulse duration, PRU_CLOCK High	10		ns
PRPC4	t _{su} (PRU_DATAIN-PRU_CLK)	Setup time, PRU_DATAIN valid before PRU_CLOCK active edge	4		ns
PRPC5	t _{th} (PRU_CLOCK-PRU_DATAIN)	Hold time, PRU_DATAIN valid after PRU_CLOCK active edge	0		ns

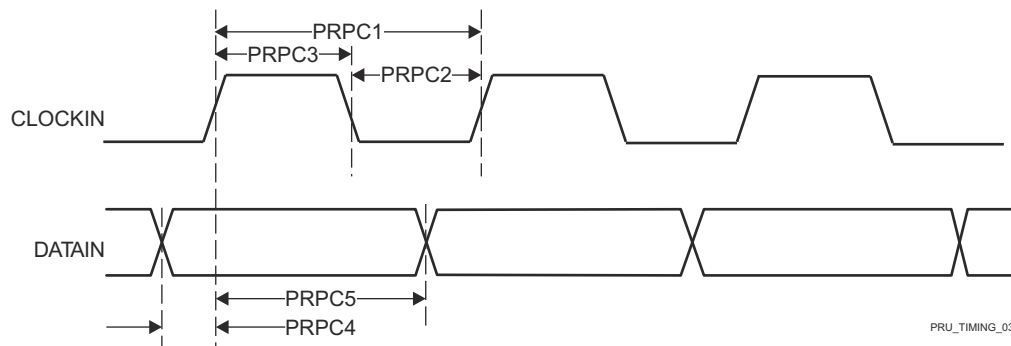

PRU_TIMING_03

图 7-45. PRU_ICSSM PRU Parallel Capture Timing Requirements - Rising Edge Mode



图 7-46. PRU_ICSSM PRU Parallel Capture Timing Requirements - Falling Edge Mode

PRU_ICSSM PRU Timing Requirements - Shift In Mode

NO.	PARAMETER	DESCRIPTION	MIN	MAX	UNIT
PRSI1	$t_w(\text{PRU_DATAINH})$	Pulse duration, PRU_DATAIN High	$2 + 2P^{(1)}$		ns
PRSI2	$t_w(\text{PRU_DATAINL})$	Pulse duration, PRU_DATAIN Low	$2 + 2P^{(1)}$		ns

(1) P = Internal shift in clock period, defined by PRU_GPI_DIV0 and PRU0_GPI_DIV1 bit fields in the GPCFGn register.

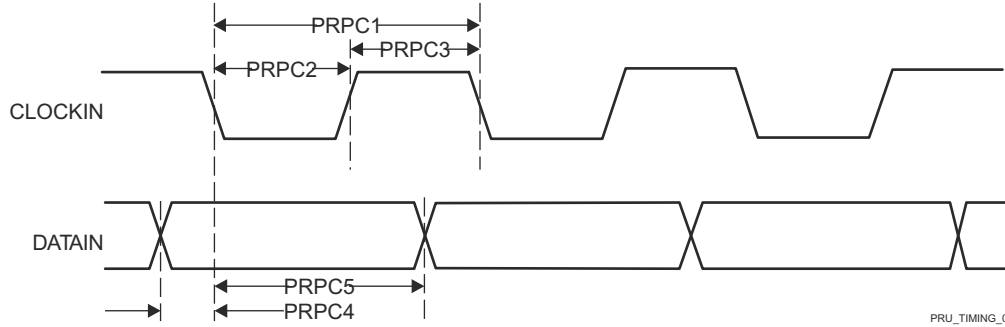

图 7-47. PRU_ICSSM PRU Shift In Timing

PRU_ICSSM PRU Switching Characteristics - Shift Out Mode

NO.	PARAMETER	DESCRIPTION	MIN	MAX	UNIT
PRSO1	$t_c(\text{PRU_CLOCKOUT})$	Cycle time, PRU_CLOCKOUT	10		ns
PRSO2L	$t_w(\text{PRU_CLOCKOUTL})$	Pulse duration, PRU_CLOCKOUT Low	$-0.3 + 0.475 \times P^{(1)} \times Z^{(2)}$		ns
PRSO2H	$t_w(\text{PRU_CLOCKOUTH})$	Pulse duration, PRU_CLOCKOUT High	$-0.3 + 0.475 \times P^{(1)} \times Y^{(3)}$		ns
PRSO3	$t_d(\text{PRU_CLOCKOUT-PRU_DATAOUT})$	Delay time, PRU_CLOCKOUT to PRU_DATAOUT Valid	0	3	ns

- (1) P = Software programmable shift out clock period, defined by PRU0_GPI_DIV0 and PRU0_GPI_DIV1 bit fields in the GPCFGn register.
- (2) The Z parameter is defined as follows:
 If PRU0_GPI_DIV0 and PRU0_GPI_DIV1 are INTEGERS -or- if PRU0_GPI_DIV0 is a NON-INTEGER and PRU0_GPI_DIV1 is an EVEN INTEGER then,
 Z equals $(\text{PRU0_GPI_DIV0} \times \text{PRU0_GPI_DIV1})$.
 If PRU0_GPI_DIV0 is a NON-INTEGER and PRU0_GPI_DIV1 is an ODD INTEGER then,
 Z equals $(\text{PRU0_GPI_DIV0} \times \text{PRU0_GPI_DIV1} + 0.5)$.
 If PRU0_GPI_DIV0 is an INTEGER and PRU0_GPI_DIV1 is a NON-INTEGER then,
 Z equals $(\text{PRU0_GPI_DIV0} \times \text{PRU0_GPI_DIV1} + 0.5 \times \text{PRU0_GPI_DIV0})$.
 If PRU0_GPI_DIV0 and PRU0_GPI_DIV1 are NON-INTEGERS then,
 Z equals $(\text{PRU0_GPI_DIV0} \times \text{PRU0_GPI_DIV1} + 0.25 \times \text{PRU0_GPI_DIV0})$.
- (3) The Y parameter is defined as follows:
 If PRU0_GPI_DIV0 and PRU0_GPI_DIV1 are INTEGERS -or- if PRU0_GPI_DIV0 is a NON-INTEGER and PRU0_GPI_DIV1 is an EVEN INTEGER then,
 Y equals $(\text{PRU0_GPI_DIV0} \times \text{PRU0_GPI_DIV1})$.
 If PRU0_GPI_DIV0 is a NON-INTEGER and PRU0_GPI_DIV1 is an ODD INTEGER then,
 Y equals $(\text{PRU0_GPI_DIV0} \times \text{PRU0_GPI_DIV1} - 0.5)$.
 If PRU0_GPI_DIV0 is an INTEGER and PRU0_GPI_DIV1 is a NON-INTEGER then,
 Y equals $(\text{PRU0_GPI_DIV0} \times \text{PRU0_GPI_DIV1} - 0.5 \times \text{PRU0_GPI_DIV0})$.
 If PRU0_GPI_DIV0 and PRU0_GPI_DIV1 are NON-INTEGERS then,
 Y1 equals $(\text{PRU0_GPI_DIV0} \times \text{PRU0_GPI_DIV1} - 0.25 \times \text{PRU0_GPI_DIV0})$ and

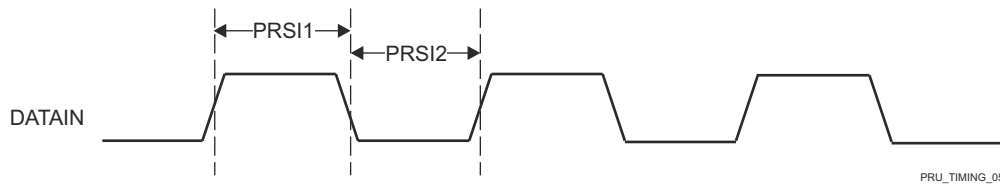
Y2 equals (PRU0_GPI_DIV0 * PRU0_GPI_DIV1 + 0.25 * PRU0_GPI_DIV0), where Y1 is the first high pulse and Y2 is the second high pulse.



图 7-48. PRU_ICSSM PRU Shift Out Timing

7.10.4.14.2 PRU_ICSSM PRU Sigma Delta and Peripheral Interface

PRU_ICSSM PRU Sigma Delta and Peripheral Interface Timing Conditions

PARAMETER		MIN	MAX	UNIT
INPUT CONDITIONS				
SR _i	Input Slew Rate	1	3	V/ns
OUTPUT CONDITIONS				
C _L	Output Load Capacitance	2	18	pF

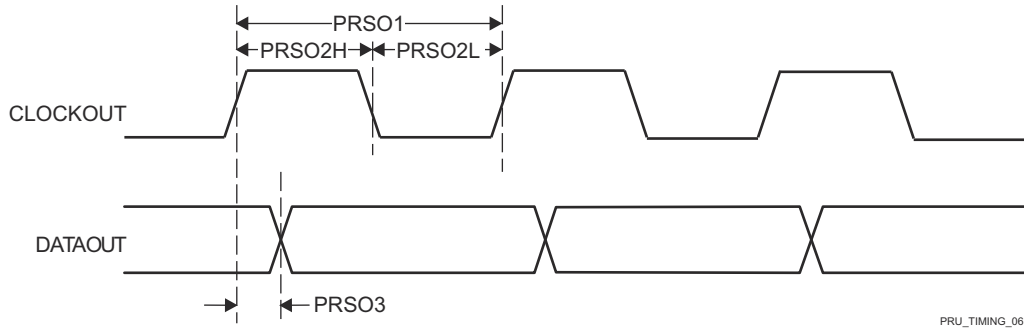
PRU_ICSSM PRU Timing Requirements - Sigma Delta Mode

NO.	PARAMETER	DESCRIPTION	MIN	MAX	UNIT
PRSD1	t _c (SD_CLK)	Cycle time, SD_CLK	40		ns
PRSD2L	t _w (SD_CLKL)	Pulse duration, SD_CLK Low	20		ns
PRSD2H	t _w (SD_CLKH)	Pulse duration, SD_CLK High	20		ns
PRSD3	t _{su} (SD_D-SDCLK)	Setup time, SD_D valid before SD_CLK active edge	10		ns
PRSD4	t _{su} (SDCLK-SD_D)	Hold time, SD_D valid after SD_CLK active edge	5		ns



图 7-49. PRU_ICSSM PRU SD_CLK Falling Active Edge



图 7-50. PRU_ICSSM PRU SD_CLK Rising Active Edge

PRU_ICSSM PRU Timing Requirements - Peripheral Interface Mode

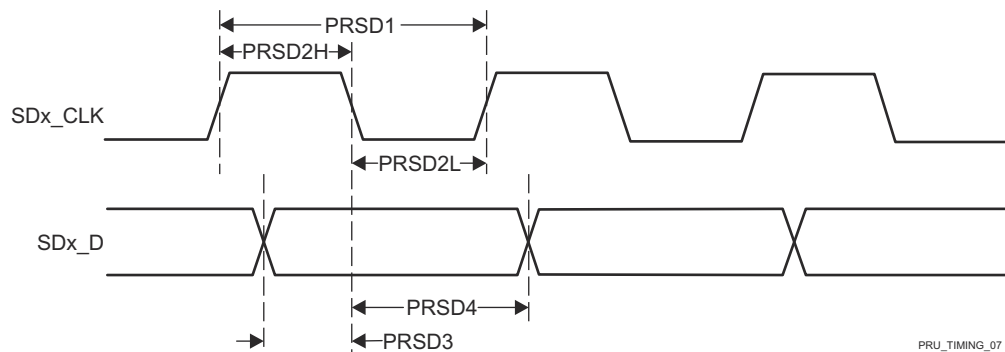
NO.	PARAMETER	DESCRIPTION	MIN	MAX	UNIT
PRPIF1	$t_w(\text{PIF_DATA_INH})$	Pulse duration, PIF_DATA_IN High	$2 + 0.475 \times (4 \times P^{(1)})$		ns
PRPIF2	$t_w(\text{PIF_DATA_INL})$	Pulse duration, PIF_DATA_IN Low	$2 + 0.475 \times (4 \times P^{(1)})$		ns

(1) P = 1x (or TX) clock period, defined by TX_DIV_FACTOR and TX_DIV_FACTOR_FRAC in the CFG_ED_P<n>_TXCFG register.

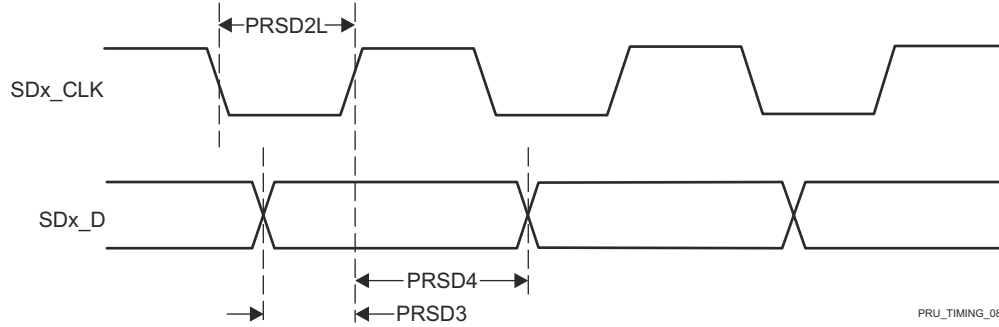

图 7-51. PRU_ICSSM PRU Peripheral Interface Timing Requirements

PRU_ICSSM PRU Switching Characteristics - Peripheral Interface Mode

NO.	PARAMETER	DESCRIPTION	MIN	MAX	UNIT
PRPIF3	$t_c(\text{PIF_CLK})$	Cycle time, PIF_CLK	30		ns
PRPIF4	$t_w(\text{PIF_CLKH})$	Pulse duration, PIF_CLK High	$0.475P^{(1)}$		ns
PRPIF5	$t_w(\text{PIF_CLKL})$	Pulse duration, PIF_CLK Low	$0.475P^{(1)}$		ns
PRPIF6	$t_d(\text{PIF_CLK-PIF_DATA_OUT})$	Delay time, PIF_CLK fall to PIF_DATA_OUT	- 5	5	ns
PRPIF7	$t_d(\text{PIF_CLK-PIF_DATA_EN})$	Delay time, PIF_CLK fall to PIF_DATA_EN	- 5	5	ns

(1) P = 1x (or TX) clock period, defined by TX_DIV_FACTOR and TX_DIV_FACTOR_FRAC in the CFG_ED_P<n>_TXCFG register.

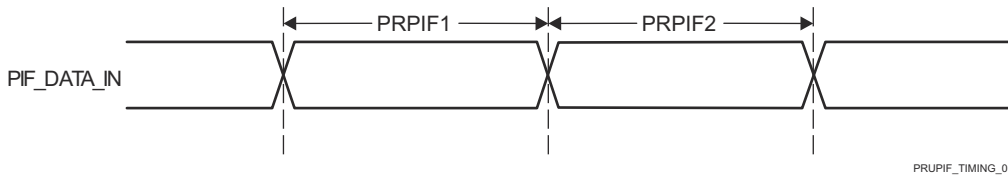

图 7-52. PRU_ICSSM PRU Peripheral Interface Switching Characteristics

7.10.4.14.3 PRU_ICSSM Pulse Width Modulation (PWM)

PRU_ICSSM PWM Timing Conditions

PARAMETER		MIN	MAX	UNIT
INPUT CONDITIONS				
SR _i	Input Slew Rate	1	4	V/ns
OUTPUT CONDITIONS				
C _L	Output Load Capacitance	2	7	pF

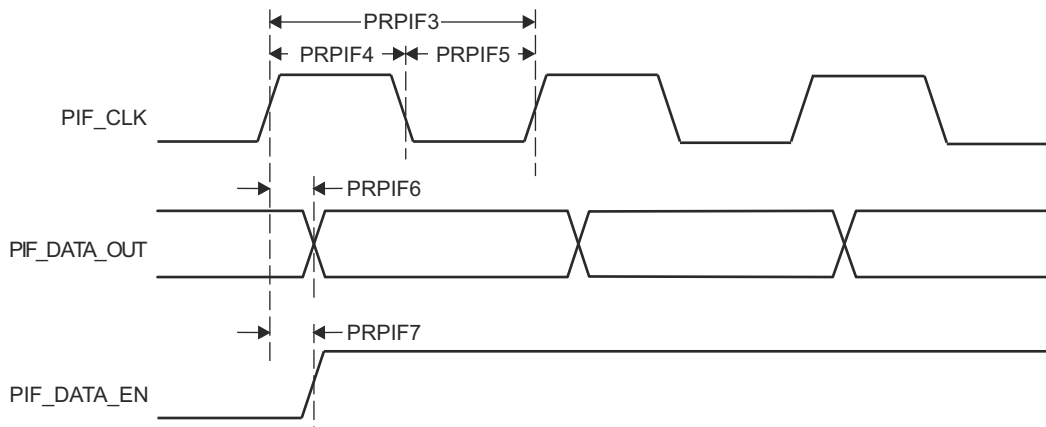
PRU_ICSSM PWM Switching Characteristics

NO.	PARAMETER	DESCRIPTION	MIN	MAX	UNIT
PRPWM1	t _{sk} (PWM_A/B)	PWM_A/B skew		0	ns



图 7-53. PRU_ICSSM PWM Timing

7.10.4.14.4 PRU_ICSSM Industrial Ethernet Peripheral (IEP)

PRU_ICSSM IEP Timing Conditions

PARAMETER		MIN	MAX	UNIT
INPUT CONDITIONS				
SR _i	Input Slew Rate	1	3	V/ns
OUTPUT CONDITIONS				
C _L	Output Load Capacitance	1	7	pF

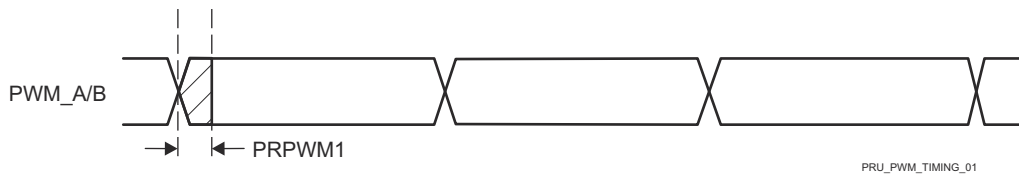
PRU_ICSSM IEP Timing Requirements - Input Validated with SYNCx

NO.	PARAMETER	DESCRIPTION	MIN	MAX	UNIT
PRIEP1	t _w (EDC_SYNCx_OUTL)	Pulse duration, EDC_SYNCx_OUT Low	- 2 + 20P ⁽¹⁾		ns
PRIEP2	t _w (EDC_SYNCx_OUTH)	Pulse duration, EDC_SYNCx_OUT High	- 2 + 20P ⁽¹⁾		ns
PRIEP3	t _{su} (EDIO_DATA_IN-EDC_SYNCx_OUT)	Setup time, EDIO_DATA_IN valid before EDC_SYNCx_OUT active edge	20		ns
PRIEP4	t _h (EDC_SYNCx_OUT-EDIO_DATA_IN)	Hold time, EDIO_DATA_IN valid after EDC_SYNCx_OUT active edge	20		ns

(1) P = PRU-ICSS IEP clock source period.



图 7-54. PRU_ICSSM IEP SYNC Timing Requirements

PRU_ICSSM IEP Timing Requirements - Digital IOs

NO.	PARAMETER	DESCRIPTION	MIN	MAX	UNIT
IEPIO1	$t_w(\text{EDIO_OUTVALIDL})$	Pule duration, EDIO_OUTVALID Low	$-2 + 14P^{(1)}$		ns
IEPIO2	$t_w(\text{EDIO_OUTVALIDH})$	Pule duration, EDIO_OUTVALID High	$-2 + 32P^{(1)}$		ns
IEPIO3	$t_d(\text{EDIO_OUTVALID-EDIO_DATA_OUT})$	Delay time, EDIO_OUTVALID to EDIO_DATA OUT	0	$18P^{(1)}$	ns
IEPIO4	$t_{sk}(\text{EDIO_DATA_OUT})$	EDIO_DATA_OUT skew	6		ns

(1) P = PRU_ICSS IEP clock source period.

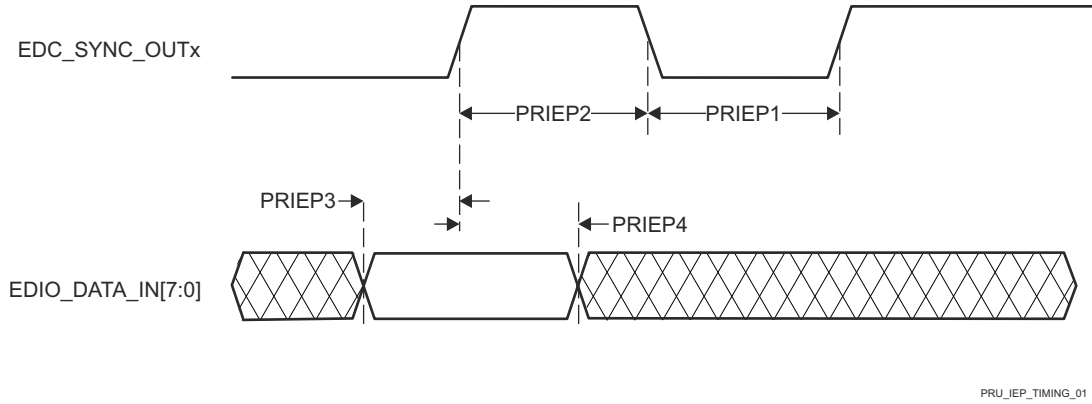

图 7-55. PRU_ICSSM IEP Digital IOs Timing Requirements

PRU_ICSSM IEP Timing Requirements - LATCHx_IN

NO.	PARAMETER	DESCRIPTION	MIN	MAX	UNIT
PRLA1	$t_w(\text{EDC_LATCHx_INL})$	Pule duration, EDC_LATCHx_IN Low	$2 + 3P^{(1)}$		ns
PRLA2	$t_w(\text{EDC_LATCHx_INH})$	Pule duration, EDC_LATCHx_IN High	$2 + 3P^{(1)}$		ns

(1) P = PRU-ICSS IEP clock source period.

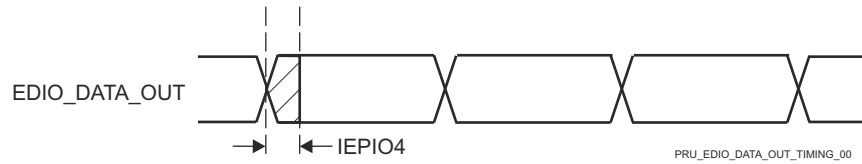

图 7-56. PRU_ICSSM IEP LATCH_INx Timing Requirements

7.10.4.14.5 PRU_ICSSM Universal Asynchronous Receiver Transmitter (UART)

PRU_ICSSM UART Timing Conditions

PARAMETER	MIN	MAX	UNIT
INPUT CONDITIONS			

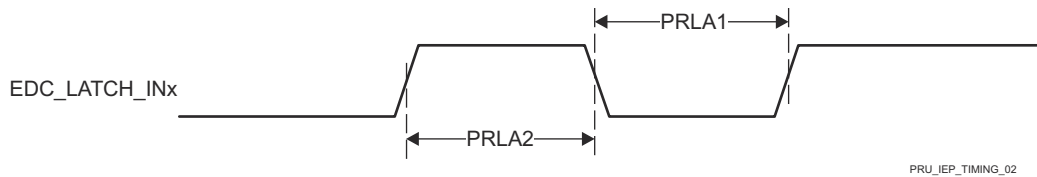
PARAMETER		MIN	MAX	UNIT
SR _i	Input Slew Rate	0.01	0.33	V/ns
OUTPUT CONDITIONS				
C _L	Output Load Capacitance	1	30	pF

PRU_ICSSM UART Timing Requirements

NO.	PARAMETER	DESCRIPTION	MIN	MAX	UNIT
PRUR1H	t _w (RXH)	Pulse duration, Receive start, stop, data bit High	U ⁽¹⁾		ns
PRUR1L	t _w (RXL)	Pulse duration, Receive start, stop, data bit Low	- 2 + U ⁽¹⁾		ns

(1) U = UART baud time = 1/programmed baud rate.

PRU_ICSSM UART Switching Characteristics

NO.	PARAMETER	DESCRIPTION	MIN	MAX	UNIT
PRUR2	f _(baud)	Maximum programmable baud rate	U ⁽¹⁾		ns
PRUR3H	t _w (TXH)	Pulse duration, Transmit start, stop, data bit High	- 2 + U ⁽¹⁾		ns

(1) U = UART baud time = 1/programmed baud rate.



图 7-57. PRU_ICSSM UART Timing Requirements and Switching Characteristics

7.10.4.14.6 PRU_ICSSM Enhanced Capture Peripheral (ECAP)

PRU_ICSSM ECAP Timing Conditions

PARAMETER		MIN	MAX	UNIT
INPUT CONDITIONS				
SR _i	Input Slew Rate	1	3	V/ns
OUTPUT CONDITIONS				
C _L	Output Load Capacitance	2	7	pF

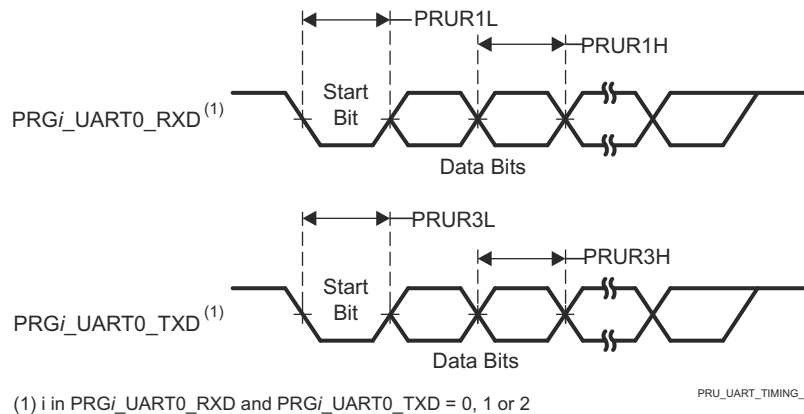
PRU_ICSSM ECAP Timing Requirements

NO.	PARAMETER	DESCRIPTION	MIN	MAX	UNIT
PREP1	t _w (CAP)	Pulse duration, Capture input (asynchronous)	2 + 2P ⁽¹⁾		ns
PREP2	t _w (SYNCl)	Pulse duration, Sync input (asynchronous)	2 + 2P ⁽¹⁾		ns

(1) P = core_clk period



图 7-58. PRU_ICSSM ECAP Timing

PRU_ICSSM ECAP Switching Characteristics

NO.	PARAMETER	DESCRIPTION	MIN	MAX	UNIT
PREP3	$t_{w(APWM)}$	Pulse duration, Auxillary PWM (APWM) output high/low	$2P^{(1)}$		ns
PREP4	$t_{w(SYNCO)}$	Pulse duration, Sync output (asynchronous)	$P^{(1)}$		ns

(1) P = core_clk period

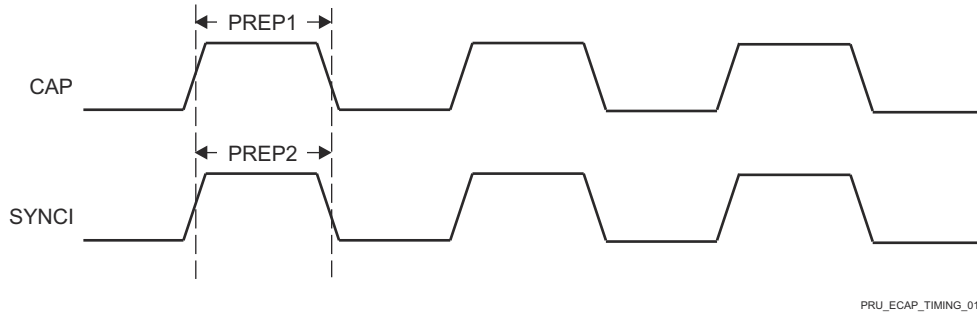

图 7-59. PRU_ICSSM ECAP Switching Characteristics

7.10.4.15 SDFM

For more information, see *Sigma Delta Filter Module* section in the device TRM.

SDFM Timing Conditions

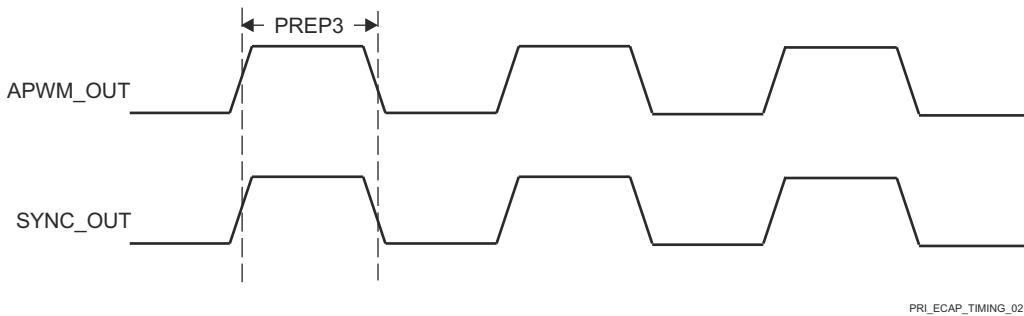
PARAMETER	MODE	MIN	MAX	UNIT
INPUT CONDITIONS				
SR_i	Input Slew Rate	Mode 0	0.5	5 V/ns

SDFM Switching Characteristics

(2)

NO.	PARAMETER	DESCRIPTION	MODE	MIN	MAX	UNIT
M0-1	$t_c(SDC)$	Cycle time, SDx_Cy	Mode 0	$5P^{(1)}$	$256P^{(1)}$	ns
M0-2	$t_w(SDCHL)$	Pulse duration, SDx_Cy (high/low)	Mode 0	$2P^{(1)}$		ns
M0-3	$t_{sh}(SDDV-SDCH)$	Setup time, SDx_dy valid before SDx_Cy high	Mode 0	$2P^{(1)}$		ns
M0-4	$t_h(SDCH-SDD)$	Hold time, SDx_Dy wait after SDx_Cy high	Mode 0	$2P^{(1)}$		ns

(1) P = SYSCLK period in ns.

(2) Some SDFM signals are pinmuxed with I2C0 SDA and SCL pins. These pins use an alternate open drain voltage buffer and may not meet the specified parameters. Values are pending additional post-silicon validation.

7.10.4.16 UART

For more details about features and additional description information on the device Universal Asynchronous Receiver Transmitter, see the corresponding subsections within *Signal Descriptions* and *Detailed Description* sections.

For more information, see *Universal Asynchronous Receiver/Transmitter (UART)* section in the device TRM.

UART Timing Conditions

PARAMETER		MIN	MAX	UNIT
INPUT CONDITIONS				
SR _I	Input Slew Rate	0.5	5	V/ns
OUTPUT CONDITIONS				
C _L	Output Load Capacitance	1	30	pF

UART Timing Requirements

NO.	PARAMETER	DESCRIPTION	MIN	MAX	UNIT
4	t _{w(RX)}	Pulse width, receive data bit, high or low	0.95U ⁽¹⁾	1.05U ⁽¹⁾	ns
5	t _{w(CTS)}	Pulse width, receive start bit, high or low	0.95U ⁽¹⁾		ns

(1) U = UART baud time = 1 / Programmed baud rate.

UART Switching Characteristics

NO.	PARAMETER	DESCRIPTION	MODE	MIN	MAX	UNIT
	f _(baud)	Programmable baud rate	15 pF		12	MHz
			30 pF		0.115	
2	t _{w(TX)}	Pulse width, transmit data bit, high or low		U ⁽¹⁾ - 2.2	U ⁽¹⁾ + 2.2	ns
3	t _{w(RTS)}	Pulse width, transmit start bit, high or low		U ⁽¹⁾ - 2.2		ns
1	t _{d(CTS-TX)}	Delay time, receive CTS bit to transmit data		30		ns

(1) U = UART baud time = 1 / Programmed baud rate.



图 7-60. UART Timing Requirements and Switching Characteristics

7.10.5 Emulation and Debug

For more details about features and additional description information on the device Trace and JTAG interfaces, see the corresponding subsections within *Signal Descriptions* and *Detailed Description* sections.

7.10.5.1 Trace

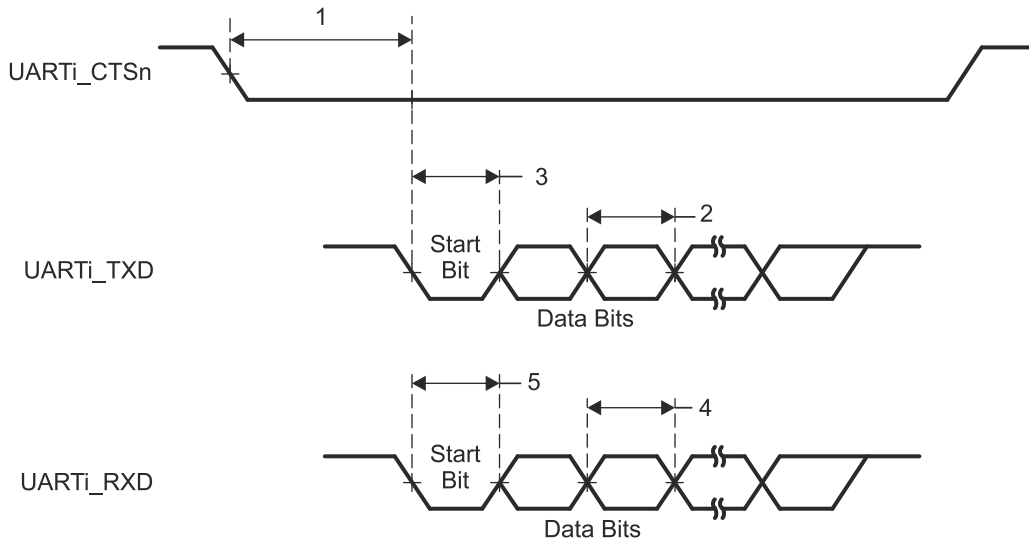
Debug Trace Timing Conditions

PARAMETER		MIN	MAX	UNIT
OUTPUT CONDITIONS				
C_L	Output Load Capacitance	2	5	pF
OUTPUT CONDITIONS				
t_d (Trace Mismatch)	Propagation delay mismatch across all traces.		200	ps

Debug Trace Switching Characteristics

NO.	PARAMETER	DESCRIPTION	MIN	MAX	UNIT
DBTR1	t_C (TRC_CLK)	Cycle time, TRC_CLK	9.75		ns
DBTR2	t_w (TRC_CLKH)	Pulse width, TRC_CLK high	4.13		ns
DBTR3	t_w (TRC_CLKL)	Pulse width, TRC_CLK low	4.13		ns
DBTR4	t_{osu} (TRC_DATAV-TRC_CLK)	Output setup time, TRC_DATA valid to TRC_CLK edge	1.22		ns
DBTR5	t_{oh} (TRC_CLK-TRC_DATAI)	Output hold time, TRC_CLK edge to TRC_DATA invalid	1.22		ns
DBTR6	t_{osu} (TRC_CTLV-TRC_CLK)	Output setup time, TRC_CTL valid to TRC_CLK edge	1.22		ns
DBTR7	t_{oh} (TRC_CLK-TRC_CTLI)	Output hold time, TRC_CLK edge to TRC_CTL invalid	1.22		ns

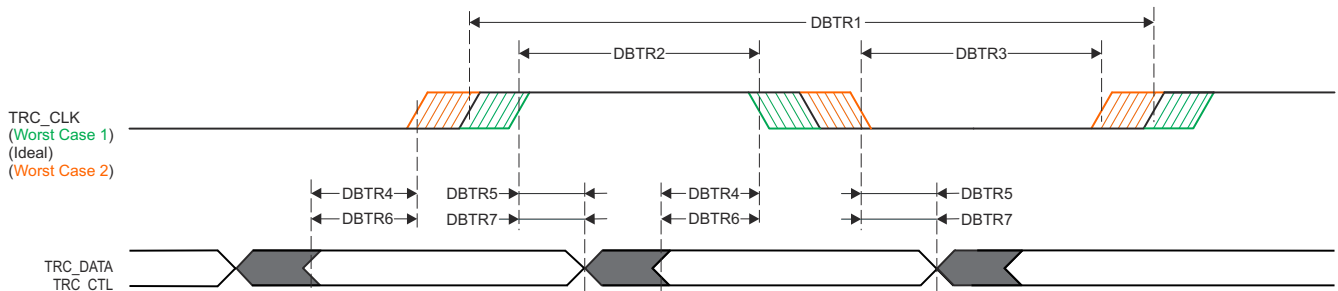

SPRS008_Debug_01

图 7-61. Trace Switching Characteristics

7.10.5.2 JTAG

JTAG Timing Conditions

PARAMETER		MIN	MAX	UNIT
INPUT CONDITIONS				
SR_i	Input Slew Rate	0.5	2.00	V/ns
OUTPUT CONDITIONS				
C_L	Output Load Capacitance	5	15	pF

JTAG Timing Requirements

NO.	PARAMETER	DESCRIPTION	MIN	MAX	UNIT
J1	$t_c(\text{TCK})$	Cycle time, TCK	40		ns
J2	$t_w(\text{TCKH})$	Pulse width, TCK high	16		ns
J3	$t_w(\text{TCKL})$	Pulse width, TCK low	16		ns
J4	$t_{su}(\text{TDI-TCKH})$	Input setup time, TDI valid to TCK high	2		ns
	$t_{su}(\text{TMS-TCKH})$	Input setup time, TMS valid to TCK high	2		
J5	$t_h(\text{TCK-TDI})$	Input hold time, TDI valid from TCK high	15.9		ns
	$t_h(\text{TCK-TMS})$	Input hold time, TMS valid from TCK high	15.9		

JTAG Switching Characteristics

NO.	PARAMETER	DESCRIPTION	MIN	MAX	UNIT
J6	$t_d(\text{TCKL-TDOI})$	Delay time, TCK low to TDO invalid	- 0.067005		ns
J7	$t_d(\text{TCKL-TDOV})$	Delay time, TCK low to TDO valid		11.89594	ns



图 7-62. JTAG Timing Requirements and Switching Characteristics

7.11 Decoupling Capacitor Requirements

7.11.1 Decoupling Capacitor Requirements

PARAMETER	DESCRIPTION	MIN	TYP	MAX	UNIT
C_{VDD}	Ground (Cap)		10		μF
C_{VDDS33}	3.3V VDDS (Cap)		10		μF
C_{VDDA33}	3.3V VDDA (Cap)		10		μF
C_{VDDS18}	1.8V VDDS (Cap)		0.1		μF
C_{VDDA18}	1.8V VDDA (Cap)		0.1		μF
C_{VDDS18_LDO}	1.8V LDO VDDS (Cap)		3.3		μF
C_{VDDA18_LDO}	1.8V LDO VDDA (Cap)		3.3		μF

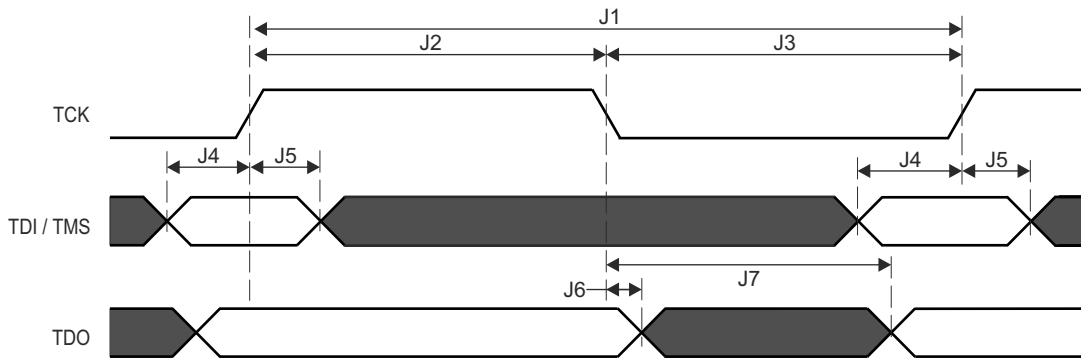
8 Detailed Description

8.1 Overview

The AM263x Sitara Arm Microcontrollers are built to meet the complex real-time processing and control needs of next generation industrial and automotive embedded projects. AM263x uniquely combines advanced compute with industry leading real-time control to meet the growing performance needs of applications such as HEV/EV (traction inverters, Onboard Chargers, and DC-DC Converters), motor drives, solar energy, and energy storage. AM263x combines up to four Cortex-R5F MCUs, a real-time control subsystem, a Hardware Security Module (HSM), and one instance of Sitara's TSN-enabled PRU-ICSSM, making AM263x designed for advanced motor control and digital power control applications.

The multiple R5F cores are arranged in cluster with 256KB of shared tightly coupled memory (TCM) along with 2MB of shared SRAM. The multiple Arm® cores can be optionally programmed to run in lock-step option for different functional safety configurations. Extensive ECC is included on on-chip memory, peripherals, and interconnect for enhanced reliability. Cryptographic acceleration and secure boot are also available on AM263x devices in addition to granular firewalls managed by the HSM for developers to design the most secure systems.

The Real-Time Control Subsystem (CONTROLSS) is a revolutionary subsystem integrated into the device. It contains multiple digital and analog control peripherals including: ADC, CMPSS, EPWM, ECAP, and EQEP, among others to enable efficient execution of critical sense/process/actuate real-time signal chain control loops. The integrated crossbar (XBAR) infrastructure enables flexible configuration and routing of external signals to internal ports and internal signals to external pins.

The PRU-ICSSM in AM263x provides the flexible industrial communications capability necessary to run TSN, EtherCAT, PROFINET, EtherNet/IP, or for standard Ethernet connectivity or custom I/O interfacing. The PRU also enables additional interfaces in the SoC including sigma delta decimation filters and absolute encoder interfaces. Additional standard ethernet ports are also provided with the CPSW interface.

TI provides a complete set of microcontroller software and development tools for the AM263x family of microcontrollers in addition to multiple pin-to-pin compatible devices for scalability and ease of use.

8.2 Processor Subsystems

8.2.1 Arm Cortex-R5F Subsystem

The R5FSS is a dual-core implementation of the Arm® Cortex®-R5F processor configured for dual-core (split) or lock-step modes of operation. It also includes accompanying memories (L1 caches and tightly-coupled memories), standard Arm® CoreSight™ debug and trace architecture, integrated Vectored Interrupt Manager (VIM), ECC Aggregators, and various wrappers for protocol conversion and address translation for easy integration into the SoC. The device supports up to two R5FSS modules for a total possible 4x functional cores (dual-core mode) or 2x functional cores (lock-step mode).

备注

The Cortex®-R5F processor is a Cortex-R5 processor that includes the optional Floating Point Unit (FPU) extension.

For more information, see *R5FSS* section in *Processors and Accelerators* chapter in the device TRM.

9 Device and Documentation Support

9.1 Device Nomenclature

To designate the stages in the product development cycle, TI assigns prefixes to the part numbers of all microprocessors (MPUs) and support tools. Each device has one of three prefixes: X, P, or null (no prefix) (for example, XAM2634AOLFGMZCZQ). Texas Instruments recommends two of three possible prefix designators for its support tools: TMDX and TMDS. These prefixes represent evolutionary stages of product development from engineering prototypes (TMDX) through fully qualified production devices and tools (TMDS).

Device development evolutionary flow:

- X** Experimental device that is not necessarily representative of the final device's electrical specifications and may not use production assembly flow.
- P** Prototype device that is not necessarily the final silicon die and may not necessarily meet final electrical specifications.
- null** Production version of the silicon die that is fully qualified.

Support tool development evolutionary flow:

- TMDX** Development-support product that has not yet completed Texas Instruments internal qualification testing.
- TMDS** Fully-qualified development-support product.

X and P devices and TMDX development-support tools are shipped against the following disclaimer:

"Developmental product is intended for internal evaluation purposes."

Production devices and TMDS development-support tools have been characterized fully, and the quality and reliability of the device have been demonstrated fully. TI's standard warranty applies.

Predictions show that prototype devices (X or P) have a greater failure rate than the standard production devices. Texas Instruments recommends that these devices not be used in any production system because their expected end-use failure rate still is undefined. Only qualified production devices are to be used.

For orderable part numbers of AM263x devices in the ZCZ package type, see the Package Option Addendum of this document, the TI website (ti.com), or contact your TI sales representative.

9.1.1 Standard Package Symbolization

备注

Some devices may have a cosmetic circular marking visible on the top of the device package which results from the production test process. In addition, some devices may also show a color variation in the package substrate which results from the substrate manufacturer. These differences are cosmetic only with no reliability impact.



图 9-1. Printed Device Reference

9.1.2 Device Naming Convention

表 9-1. Nomenclature Description

FIELD PARAMETER	FIELD DESCRIPTION	VALUE	DESCRIPTION
a ⁽¹⁾	Device evolution stage	X	Prototype
		P	Preproduction (production test flow, no reliability data)
		BLANK	Production
BBBBBB	Base production part number	AM2634	See 表 5-1, <i>Device Comparison</i>
		AM2632	
		AM2631	
r	Device revision	A	SR 1.0
		B	SR 1.0A
Z	Device Speed and Memory Grades	M	See 节 7.5, <i>Operating Performance Points</i>
		N	
		O	
		P	
f	Features (see 表 5-1, <i>Device Comparison</i>)	C	Standard Analog Only
		D	ICSS + Standard Analog
		E	ICSS + EtherCat HW Accelerator + CAN-FD Supported + Standard Analog
		F	ICSS + EtherCAT HW Accelerator + CAN-FD Supported + Pre-integrated Stacks Enabled + Standard Analog
		J	Enhanced Analog Only
		K	ICSS + Enhanced Analog
		L	ICSS + EtherCat HW Accelerator + CAN-FD Supported + Enhanced Analog
Y	Functional Safety	G	Non-Functional Safety (AM2631 only)
		F	Functional Safety
y	Security	H	Secure
t ⁽²⁾	Junction Temperature (see 节 7.4, <i>ROC</i>)	A	-40°C to 105°C - Extended Industrial
		M	-40°C to 150°C - Extended Automotive
PPP	Package Designator	ZCZ	ZCZ NFBGA-N324 (15 mm × 15 mm) Package
Q1	Automotive Designator	Q1	Auto Qualified (AEC-Q100)
		BLANK	Standard
XXXXXXX			Lot Trace Code (LTC)
YYY			Production Code; For TI use only
ZZZ			Production Code; For TI use only
O			Pin one designator
G1			ECAT—Green package designator

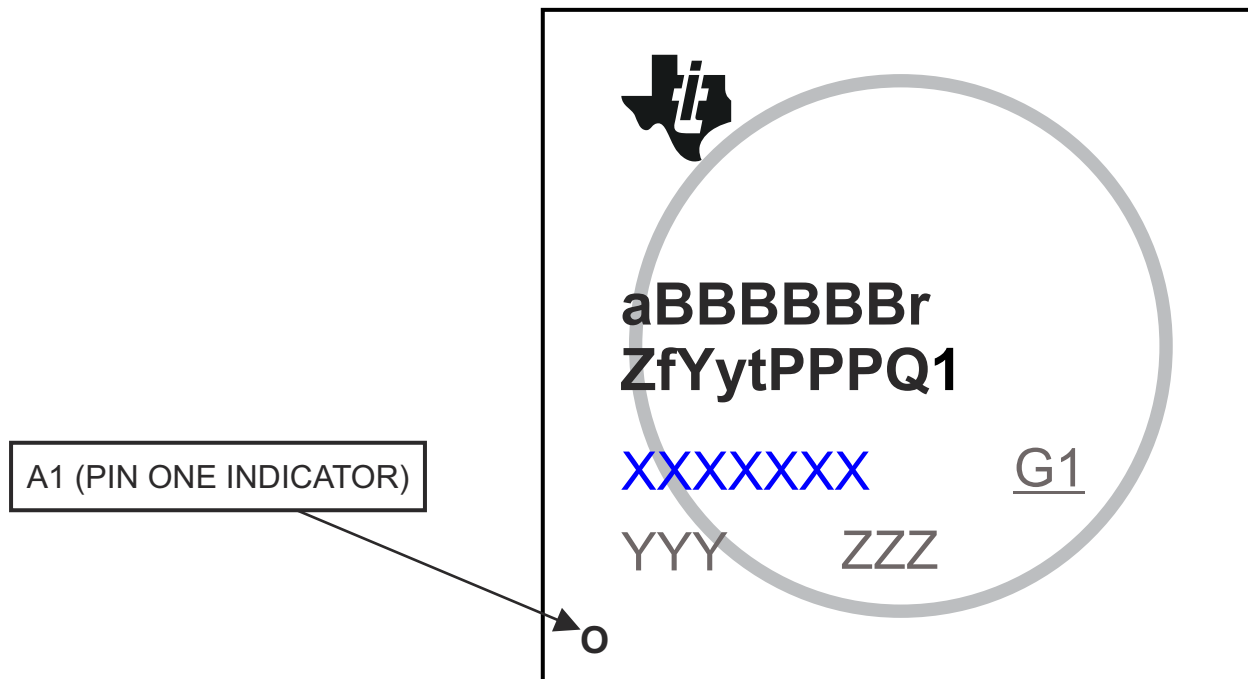
- (1) To designate the stages in the product development cycle, TI assigns prefixes to the part numbers. These prefixes represent evolutionary stages of product development from engineering prototypes through fully qualified production devices. Prototype devices are shipped against the following disclaimer:
“This product is still in development and is intended for internal evaluation purposes.”
Notwithstanding any provision to the contrary, TI makes no warranty expressed, implied, or statutory, including any implied warranty of merchantability of fitness for a specific purpose, of this device.
- (2) Applies to device max junction temperature.

备注

BLANK in the symbol or part number is collapsed so there are no gaps between characters.

9.2 Tools and Software

The following products support development for AM263x platforms:

Development Tools

Code Composer Studio™ Integrated Development Environment Code Composer Studio (CCS) Integrated Development Environment (IDE) is a development environment that supports TI's Microcontroller and Embedded Processors portfolio. Code Composer Studio comprises a suite of tools used to develop and debug embedded applications. It includes an optimizing C/C++ compiler, source code editor, project build environment, debugger, profiler, and many other features. The intuitive IDE provides a single user interface taking you through each step of the application development flow. Familiar tools and interfaces allow users to get started faster than ever before. Code Composer Studio combines the advantages of the Eclipse software framework with advanced embedded debug capabilities from TI resulting in a compelling feature-rich development environment for embedded developers.

SysConfig-PinMux Tool The SysConfig-PinMux Utility is a software tool which provides a Graphical User Interface for configuring pin multiplexing settings, resolving conflicts and specifying I/O cell characteristics for TI Embedded Processor devices. The tool can be used to automatically calculate the optimal pinmux configuration to satisfy entered system requirements. The tool will generate output C header/code files that can be imported into software development kits (SDKs) and used to configure customer's software to meet custom hardware requirements.

For a complete listing of development-support tools for the processor platform, visit the Texas Instruments website at ti.com. For information on pricing and availability, contact the nearest TI field sales office or authorized distributor.

9.3 Documentation Support

To receive notification of documentation updates, navigate to the device product folder on ti.com. Click on *Subscribe to updates* to register and receive a weekly digest of any product information that has changed. For change details, review the revision history included in any revised document.

The following documents describe the AM263x devices.

Technical Reference Manual

AM263x Processors Silicon Revision 1.0 Technical Reference Manual Details the integration, the environment, the functional description, and the programming models for each peripheral and subsystem in the AM263x family of devices.

Errata

AM263x Processors Silicon Revision 1.0 Silicon Errata Describes the known exceptions to the functional specifications for the device.

9.4 支持资源

TI E2E™ 支持论坛是工程师的重要参考资料，可直接从专家获得快速、经过验证的解答和设计帮助。搜索现有解答或提出自己的问题可获得所需的快速设计帮助。

链接的内容由各个贡献者“按原样”提供。这些内容并不构成 TI 技术规范，并且不一定反映 TI 的观点；请参阅 TI 的《使用条款》。

9.5 Trademarks

Sitara™, Code Composer Studio™, and TI E2E™ are trademarks of Texas Instruments.

CoreSight™ is a trademark of Arm Limited (or its subsidiaries) in the US and/or elsewhere.

Arm® and Cortex® are registered trademarks of Arm Limited (or its subsidiaries) in the US and/or elsewhere.

EtherCAT® is a registered trademark of Beckhoff Automation GmbH.

PROFINET® is a registered trademark of PROFINET International.

IO-Link® is a registered trademark of PROFIBUS Nutzerorganisation e.V. eingetragener verein (e.v.) FED REP GERMANY.

所有商标均为其各自所有者的财产。

9.6 Electrostatic Discharge Caution



This integrated circuit can be damaged by ESD. Texas Instruments recommends that all integrated circuits be handled with appropriate precautions. Failure to observe proper handling and installation procedures can cause damage.

ESD damage can range from subtle performance degradation to complete device failure. Precision integrated circuits may be more susceptible to damage because very small parametric changes could cause the device not to meet its published specifications.

9.7 术语表

TI 术语表

本术语表列出并解释了术语、首字母缩略词和定义。

10 Mechanical, Packaging, and Orderable Information

10.1 Packaging Information

The following pages include mechanical, packaging, and orderable information. This information is the most current data available for the designated devices. This data is subject to change without notice and revision of this document. For browser-based versions of this data sheet, refer to the left-hand navigation.

PACKAGING INFORMATION

Orderable Device	Status (1)	Package Type	Package Drawing	Pins	Package Qty	Eco Plan (2)	Lead finish/ Ball material (6)	MSL Peak Temp (3)	Op Temp (°C)	Device Marking (4/5)	Samples
XAM2634BOLFHMZCZQ	ACTIVE	NFBGA	ZCZ	324	1	TBD	Call TI	Call TI	-40 to 150		Samples
XAM2634BOMFHAZCZ	ACTIVE	NFBGA	ZCZ	324	1	TBD	Call TI	Call TI	-40 to 105		Samples

(1) The marketing status values are defined as follows:

ACTIVE: Product device recommended for new designs.

LIFEBUY: TI has announced that the device will be discontinued, and a lifetime-buy period is in effect.

NRND: Not recommended for new designs. Device is in production to support existing customers, but TI does not recommend using this part in a new design.

PREVIEW: Device has been announced but is not in production. Samples may or may not be available.

OBSELETE: TI has discontinued the production of the device.

(2) **RoHS:** TI defines "RoHS" to mean semiconductor products that are compliant with the current EU RoHS requirements for all 10 RoHS substances, including the requirement that RoHS substance do not exceed 0.1% by weight in homogeneous materials. Where designed to be soldered at high temperatures, "RoHS" products are suitable for use in specified lead-free processes. TI may reference these types of products as "Pb-Free".

RoHS Exempt: TI defines "RoHS Exempt" to mean products that contain lead but are compliant with EU RoHS pursuant to a specific EU RoHS exemption.

Green: TI defines "Green" to mean the content of Chlorine (Cl) and Bromine (Br) based flame retardants meet JS709B low halogen requirements of <=1000ppm threshold. Antimony trioxide based flame retardants must also meet the <=1000ppm threshold requirement.

(3) MSL, Peak Temp. - The Moisture Sensitivity Level rating according to the JEDEC industry standard classifications, and peak solder temperature.

(4) There may be additional marking, which relates to the logo, the lot trace code information, or the environmental category on the device.

(5) Multiple Device Markings will be inside parentheses. Only one Device Marking contained in parentheses and separated by a "~" will appear on a device. If a line is indented then it is a continuation of the previous line and the two combined represent the entire Device Marking for that device.

(6) Lead finish/Ball material - Orderable Devices may have multiple material finish options. Finish options are separated by a vertical ruled line. Lead finish/Ball material values may wrap to two lines if the finish value exceeds the maximum column width.

Important Information and Disclaimer:The information provided on this page represents TI's knowledge and belief as of the date that it is provided. TI bases its knowledge and belief on information provided by third parties, and makes no representation or warranty as to the accuracy of such information. Efforts are underway to better integrate information from third parties. TI has taken and continues to take reasonable steps to provide representative and accurate information but may not have conducted destructive testing or chemical analysis on incoming materials and chemicals. TI and TI suppliers consider certain information to be proprietary, and thus CAS numbers and other limited information may not be available for release.

In no event shall TI's liability arising out of such information exceed the total purchase price of the TI part(s) at issue in this document sold by TI to Customer on an annual basis.

OTHER QUALIFIED VERSIONS OF AM2634, AM2634-Q1 :

- Catalog : [AM2634](#)
- Automotive : [AM2634-Q1](#)

NOTE: Qualified Version Definitions:

- Catalog - TI's standard catalog product
- Automotive - Q100 devices qualified for high-reliability automotive applications targeting zero defects

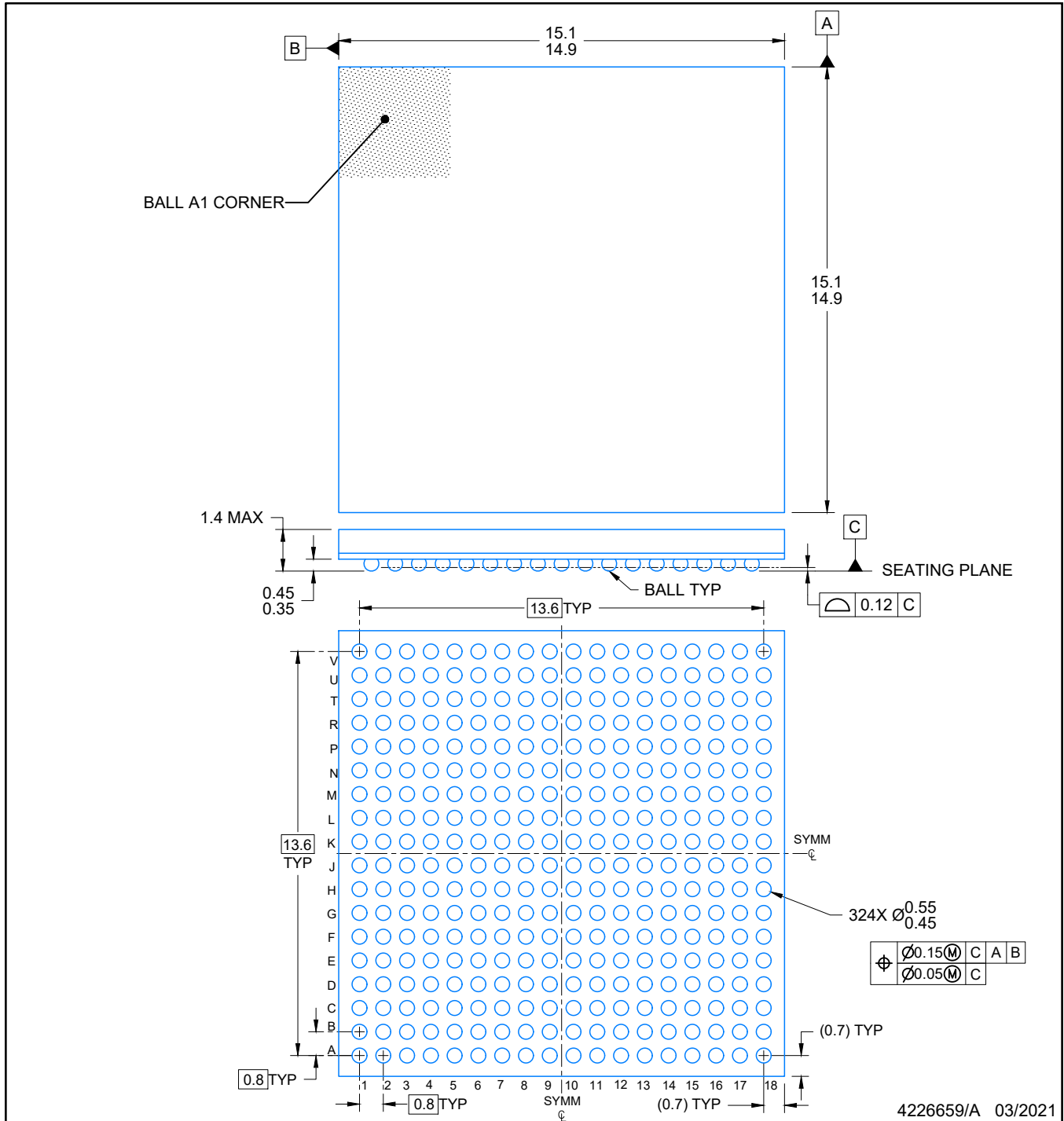

4226659/A 03/2021

NOTES:

NanoFree is a trademark of Texas Instruments.

1. All linear dimensions are in millimeters. Any dimensions in parenthesis are for reference only. Dimensioning and tolerancing per ASME Y14.5M.
2. This drawing is subject to change without notice.

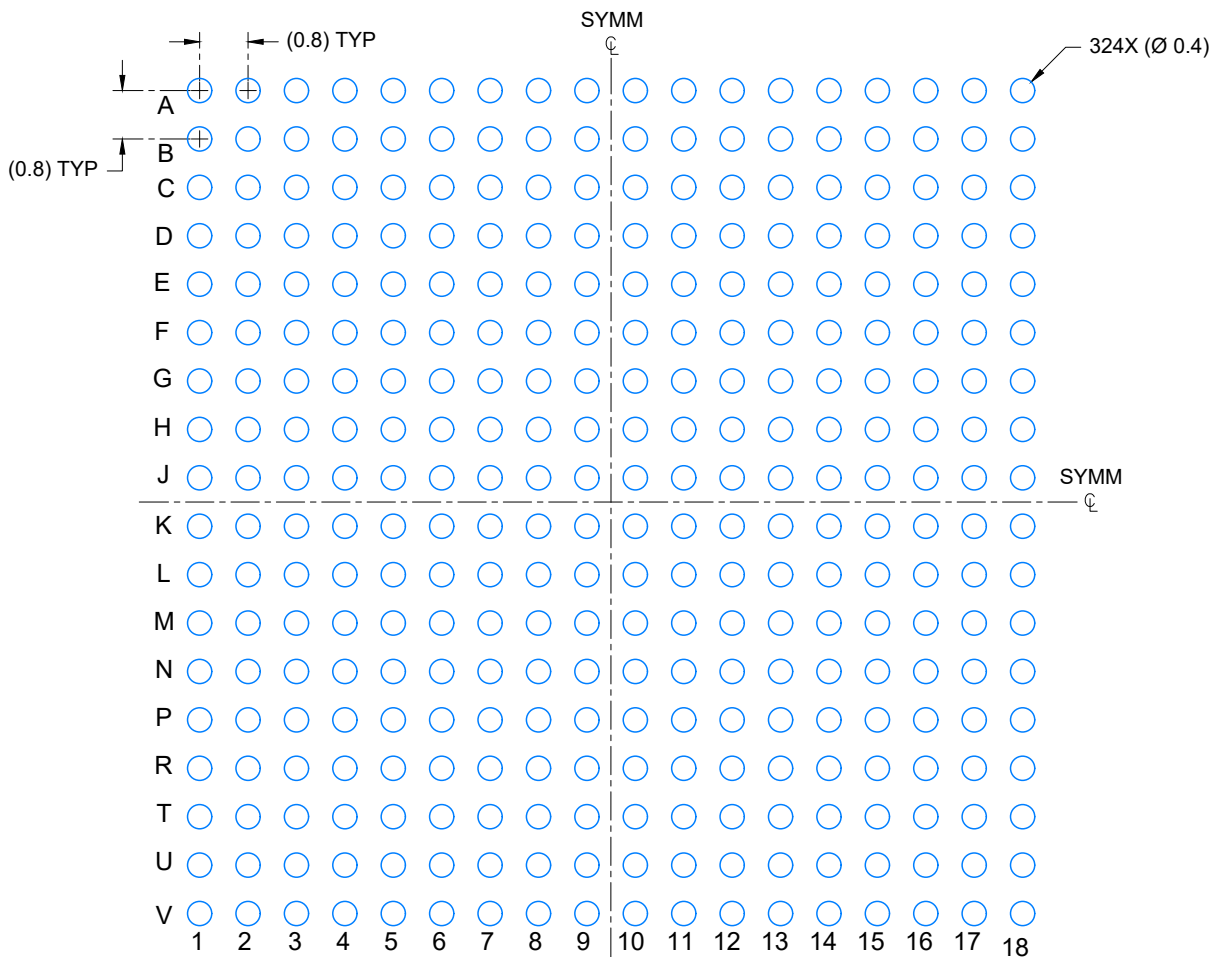

LAND PATTERN EXAMPLE
SCALE: 8X

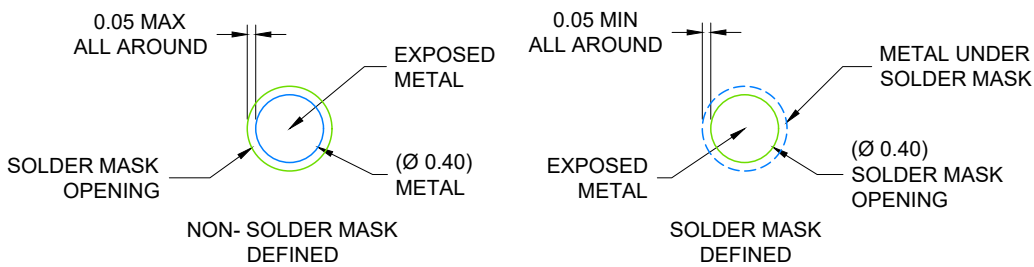

SOLDER MASK DETAILS
NOT TO SCALE

4226659/A 03/2021

NOTES: (continued)

- Final dimensions may vary due to manufacturing tolerance considerations and also routing constraints. Refer to Texas Instruments Literature number SNVA009 (www.ti.com/lit/snva009).

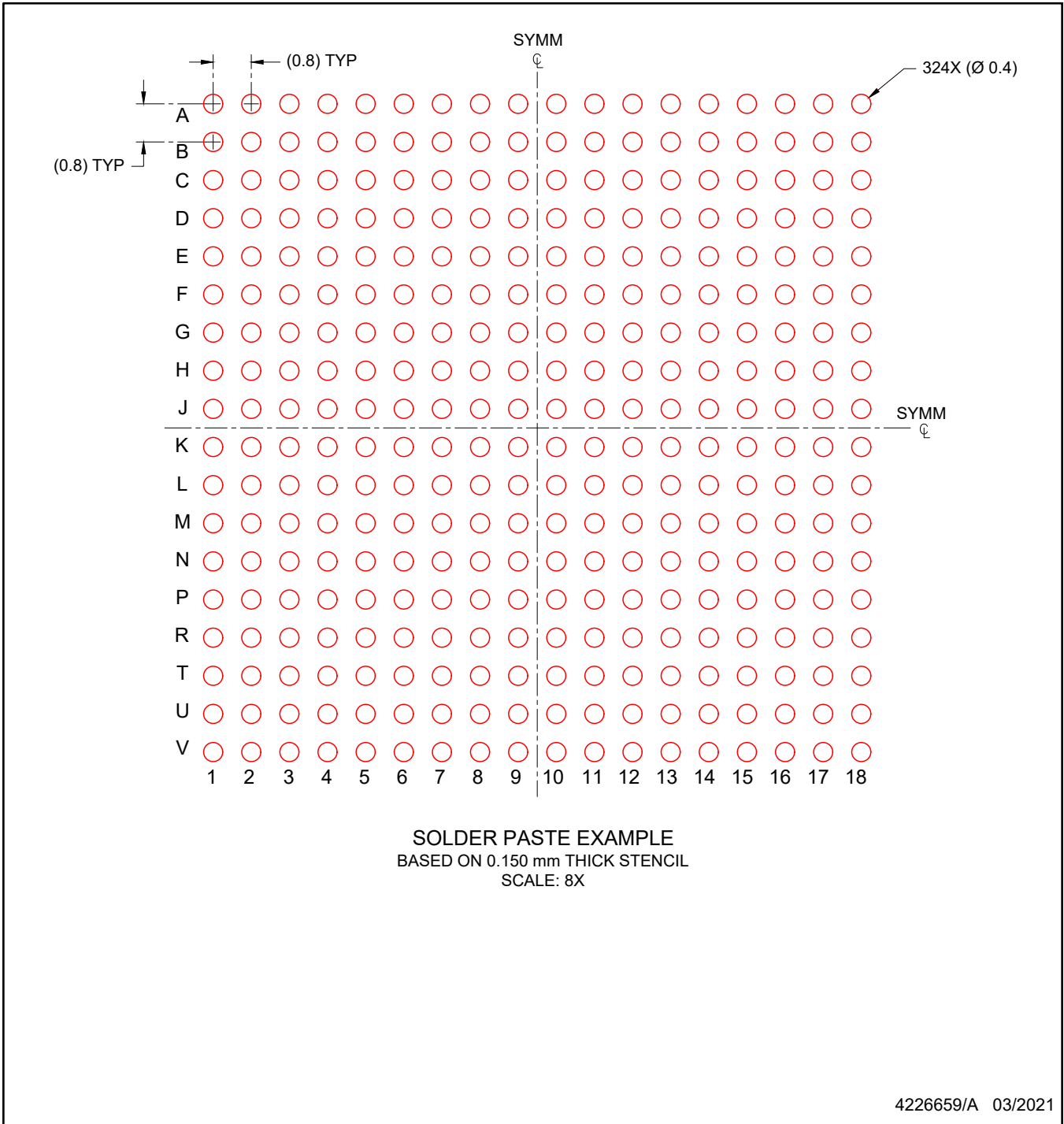

NOTES: (continued)

- 4. Laser cutting apertures with trapezoidal walls and rounded corners may offer better paste release.

重要声明和免责声明

TI“按原样”提供技术和可靠性数据（包括数据表）、设计资源（包括参考设计）、应用或其他设计建议、网络工具、安全信息和其他资源，不保证没有瑕疵且不做任何明示或暗示的担保，包括但不限于对适销性、某特定用途方面的适用性或不侵犯任何第三方知识产权的暗示担保。

这些资源可供使用 TI 产品进行设计的熟练开发人员使用。您将自行承担以下全部责任：(1) 针对您的应用选择合适的 TI 产品，(2) 设计、验证并测试您的应用，(3) 确保您的应用满足相应标准以及任何其他功能安全、信息安全、监管或其他要求。

这些资源如有变更，恕不另行通知。TI 授权您仅可将这些资源用于研发本资源所述的 TI 产品的应用。严禁对这些资源进行其他复制或展示。您无权使用任何其他 TI 知识产权或任何第三方知识产权。您应全额赔偿因在这些资源的使用中对 TI 及其代表造成的任何索赔、损害、成本、损失和债务，TI 对此概不负责。

TI 提供的产品受 [TI 的销售条款](#) 或 [ti.com](#) 上其他适用条款/TI 产品随附的其他适用条款的约束。TI 提供这些资源并不会扩展或以其他方式更改 TI 针对 TI 产品发布的适用的担保或担保免责声明。

TI 反对并拒绝您可能提出的任何其他或不同的条款。

邮寄地址：Texas Instruments, Post Office Box 655303, Dallas, Texas 75265

Copyright © 2022，德州仪器 (TI) 公司